

Service Contract to DGTREN

**Preparatory study on the environmental performance of
residential room conditioning appliances (airco and ventilation)**

Contract TREN/D1/40-2005/LOT10/S07.56606

**Study on residential ventilation - Final report
February, 2009, after SH comments**

CO-ORDINATOR: Philippe RIVIERE, ARMINES, France

PARTICIPANTS

Jérôme ADNOT, Laurent GRIGNON-MASSE, Dominique MARCHIO, Philippe RIVIERE
ARMINES, France

Philippe ANDRE, Laurie DETROUX, Jean LEBRUN, Vladut TEODOROSE
Université de Liège (ULg), Belgium

José Luis ALEXANDRE, Emanuel SA
IDMEC, University of Porto, Faculty of Eng., Portugal.

Georg BENKE, Thomas BOGNER
Austrian Energy Agency, Austria

Amanda CONROY, Roger HITCHIN, Christine POUT, Wendy THORPE
BRE, UK

Stavroula KARATASOU
IASA, Greece

Note : comfort fans are treated in another document, this report is about ventilation fans.

Legal disclaimer

The sole responsibility for the content of this report lies with the authors. It does not represent the opinion of the European Community. The European Commission is not responsible for any use that may be made of the information contained therein.

CONTENTS

| | | |
|----------|--|-----------|
| 1 | DEFINITION OF PRODUCT, STANDARDS AND LEGISLATION | 8 |
| 1.1 | PRODUCT CATEGORY AND PERFORMANCE ASSESSMENT | 8 |
| 1.1.1 | <i>Product definitions</i> | 8 |
| 1.1.2 | <i>Existing product categorisations</i> | 17 |
| 1.1.3 | <i>Functional analysis.....</i> | 19 |
| 1.2 | TEST STANDARDS | 22 |
| 1.2.1 | <i>Energy use</i> | 22 |
| 1.2.2 | <i>Noise.....</i> | 31 |
| 1.2.3 | <i>Safety</i> | 32 |
| 1.3 | EXISTING LEGISLATION..... | 33 |
| 1.3.1 | <i>Legislation and Agreements at European Community level.....</i> | 33 |
| 1.3.2 | <i>Legislation at Member State level</i> | 33 |
| 1.3.3 | <i>Third Country Legislation</i> | 33 |
| | TASK 1 SUMMARY..... | 35 |
| 2 | ECONOMIC AND MARKET ANALYSIS | 37 |
| 2.1 | GENERIC ECONOMIC DATA..... | 37 |
| 2.2 | MARKET AND STOCK DATA..... | 41 |
| 2.3 | MARKET TRENDS | 53 |
| 2.4 | CONSUMER EXPENDITURE BASE DATA | 60 |
| | TASK 2 SUMMARY..... | 61 |
| 3 | CONSUMER BEHAVIOUR AND LOCAL INFRASTRUCTURE..... | 62 |
| 3.1 | REAL LIFE EFFICIENCY | 62 |
| 3.2 | END-OF-LIFE BEHAVIOUR..... | 68 |
| 3.3 | LOCAL INFRASTRUCTURE | 68 |
| | TASK 3 SUMMARY..... | 70 |
| 4 | TECHNICAL ANALYSIS EXISTING PRODUCTS..... | 71 |
| 4.1 | PRODUCTION PHASE..... | 71 |
| 4.2 | DISTRIBUTION PHASE..... | 74 |
| 4.3 | USE PHASE (PRODUCT) –ENERGY EFFICIENCY AT FULL LOAD (FL) | 75 |
| 4.3.1 | <i>Definition of characteristic lines and BEP (Best Efficiency Point).....</i> | 75 |
| 4.3.2 | <i>Various aspects of characteristic lines</i> | 75 |
| 4.3.3 | <i>How to select one representative point on the product characteristic line (definition of one operating point representative of Full Load : FL)?</i> | 82 |
| 4.3.4 | <i>Options for EEI_{FL} (Energy Efficiency Index at Full Load) scenarios.....</i> | 84 |
| 4.3.5 | <i>Testing the options on one example.....</i> | 84 |
| 4.3.6 | <i>Extension of the full load scenarios to range hoods and products with heat recovery ...</i> | 86 |
| 4.4 | USE PHASE (SYSTEM) –ENERGY EFFICIENCY AT PART LOAD (PL) | 87 |
| 4.4.1 | <i>Reduction of various operating points to one single PL value : an existing study.....</i> | 87 |
| 4.4.2 | <i>Feasibility of one single PL (Part Load) index to represent part load gains</i> | 89 |
| 4.4.3 | <i>Definition of scenarios for EEI_{PL} (Energy Efficiency Index at part Load).....</i> | 92 |
| 4.4.4 | <i>One worked out example</i> | 94 |
| 4.4.5 | <i>Some average results</i> | 95 |
| 4.5 | END-OF-LIFE PHASE | 96 |
| | TASK 4 SUMMARY..... | 97 |
| 5 | DEFINITION OF AVERAGE BASE-CASE..... | 98 |
| 5.1 | PRODUCT-SPECIFIC INPUTS | 98 |
| 5.2 | BASE-CASE ENVIRONMENTAL IMPACT ASSESSMENT | 101 |
| 5.3 | BASE-CASE LIFE CYCLE COSTS | 103 |

| | | |
|----------|---|------------|
| 5.4 | EU TOTALS | 104 |
| 5.4.1 | <i>Impact and LCC of new products installed in 2005</i> | 104 |
| 5.4.2 | <i>Impact and LCC of all products in 2005</i> | 107 |
| 5.5 | EU-25 TOTAL SYSTEM IMPACT | 110 |
| | TASK 5 SUMMARY | 112 |
| 6 | TECHNICAL ANALYSIS BAT | 113 |
| 6.1 | STATE-OF-THE-ART IN APPLIED RESEARCH FOR THE PRODUCT INSIDE AND OUTSIDE EUROPE 113 | |
| 6.2 | IMPROVEMENTS IN MOTOR DESIGN | 113 |
| 6.3 | IMPROVEMENTS IN FAN DESIGN | 116 |
| 6.4 | IMPROVEMENTS IN INTERIOR AIR FLOW DESIGN | 117 |
| 6.5 | IMPROVEMENTS IN MOTOR AND FAN CONTROL | 117 |
| 6.6 | LIMITATION OF ELECTRIC DEMAND IN CASE OF HEAT RECOVERY | 119 |
| 6.7 | STATE-OF-THE-ART FOR NOISE CONTROL | 120 |
| | TASK 6 SUMMARY | 121 |
| 7 | IMPROVEMENT POTENTIAL FOR THE PRODUCT OF AVERAGE SIZE..... | 122 |
| 7.1 | OPTIONS PARTLY IN PLACE IN SOME PRODUCTS | 122 |
| 7.2 | IMPACTS OF OPTIONS ON A DV (NOT HOOD) OF AVERAGE SIZE | 123 |
| 7.3 | IMPACTS OF OPTIONS ON AN ICV OF AVERAGE SIZE | 123 |
| 7.4 | IMPACTS OF OPTIONS ON A DV-HOOD OF AVERAGE SIZE | 126 |
| 7.5 | ANALYSIS LLCC AND BAT FOR AVERAGE PRODUCT SIZE | 126 |
| 7.6 | LONG-TERM TARGETS (BNAT) AND SYSTEMS ANALYSIS | 129 |
| | TASK 7 SUMMARY | 131 |
| 8 | SCENARIO-, POLICY-, IMPACT- AND SENSITIVITY ANALYSIS | 132 |
| 8.1 | PREPARATION WORKS FOR POLICIES- AND ANALYSIS OF OPTIONS | 132 |
| 8.2 | ECODESIGN REQUIREMENTS | 139 |
| 8.3 | OTHER ENVIRONMENTAL REQUIREMENTS AND THEIR TREATMENT | 145 |
| 8.4 | IMPACT ANALYSIS | 147 |
| 8.5 | SENSITIVITY ANALYSIS..... | 153 |
| 8.6 | SUMMARY OF PERFORMANCE TESTING LEADING TO EEI@PL AND EEI @ FL (TO BECOME A TECHNICAL ANNEX OF ANY REQUIREMENT) | 154 |
| | APPENDIX: SHAPE OF VENTILATION FANS | 157 |
| | REFERENCES | 161 |
| | R1-DEFINITION OF PRODUCT AND STANDARDS | 161 |
| | R2-ECONOMIC AND MARKET ANALYSIS | 161 |
| | R3-CONSUMER BEHAVIOUR AND LOCAL INFRASTRUCTURE | 162 |
| | R4-TECHNICAL ANALYSIS EXISTING PRODUCTS | 162 |
| | R5-DEFINITION OF BASE-CASE | 162 |
| | R6-TECHNICAL ANALYSIS BAT | 162 |
| | R7-IMPROVEMENT POTENTIAL | 162 |
| | R8-SCENARIO-, POLICY-, IMPACT- AND SENSITIVITY ANALYSIS | 162 |

LIST OF FIGURES

| | |
|--|----|
| Figure 1-1: Different types of fans according to fluid mechanics, from Cory (1992)..... | 9 |
| Figure 1-2: Different types of building ventilation, extract from Lot 11 study on ventilation in non residential buildings (Radgen, 2007)..... | 11 |
| Figure 1-3: Roof fan implantation scheme (Cory, 1992) | 12 |
| Figure 1-4: Roof fan figures from (Cory, 1992)..... | 12 |
| Figure 1-5: appearance of kitchen hoods (courtesy of manufacturers, 2008) | 12 |

| | |
|--|-----|
| Figure 1-6: Centralized ventilation with natural air supply and mechanical extract fans, Atlantic (left: individual house, right : collective dwellings) | 14 |
| Figure 1-7: Simple flow extractor, Atlantic (left: individual house, right : collective dwellings) | 14 |
| Figure 1-8: Balanced double flow ventilation unit, Courtesy Swedish manufacturers | 15 |
| Figure 1-9: Balanced double flow ventilation system and unit, Courtesy Aldès -CFP | 16 |
| Figure 1.1-10: Passive stack fan assisted natural ventilation, Courtesy Aereco www.aereco.fr | 17 |
| Figure 1-11: Standard scheme of a mechanical natural supply mechanical exhaust system | 25 |
| Figure 1-12: Standard residential ventilation system as proposed in standard EN 13141 – Part 6 completed for the UK building code, from (SAP, 2005) | 29 |
| Figure 1-13: Certification logo of the French NF program for mechanical ventilation | 30 |
| Figure 1-14: Certification logo of the French program CSTBat | 31 |
| Figure 2-1: penetration of heat recovery in the Netherlands | 43 |
| Figure 2-2: Ventilation equipment rate of individual and collective housing (total stock) in France, from (ATEE, 2006) | 44 |
| Figure 2-3: Ventilation systems in new and existing buildings, from (Ledean, 2007) | 47 |
| Figure 2-4: Market previsions of the growth of residential mechanical ventilation in Germany (TZML, 2007) | 53 |
| Figure 3-1: Centralized mechanical exhaust and natural supply ventilation system, from (ADEME, 2007) | 64 |
| Figure 3-2: Example of ducts, Courtesy Atlantic- (CFP, 2006) | 65 |
| Figure 4-1: Bills of material of various DV fans | 72 |
| Figure 4-2: Bills of material of various ICV fans | 73 |
| Figure 4-3: Relationship between electrical power and mass of the product, all products in scope | 74 |
| Figure 4-4: Example of characteristic line of a ventilation product | 75 |
| Figure 4-5: Characteristic line of decentralised ventilation product of wall type | 76 |
| Figure 4-6: Characteristic line of decentralised ventilation product of range hood type | 76 |
| Figure 4-7: Characteristic line (Type b) of ICV product | 77 |
| Figure 4-8: Characteristic line (Type c) of ICV product with two speeds | 78 |
| Figure 4-9: Characteristic line (Type d) of products with a large zone of pressure differences in which the flow is constant | 78 |
| Figure 4-10: Characteristic line (Type e) of products that “guarantee” a constant pressure difference | 79 |
| Figure 4-11: Characteristic line (Type f) of products with variable speed | 79 |
| Figure 4-12: Characteristic line of products with heat recovery (here also with multi speed) | 80 |
| Figure 4-13: Characteristic line of products with heat recovery, with supposed equal characteristic for inlet and outlet air flows | 80 |
| Figure 4-14: Characteristic line of products with heat recovery, with supposed equal characteristic for inlet and outlet air flows, complete performance map | 81 |
| Figure 4-15: Characteristic line (type h) of fan assisted natural ventilation products | 81 |
| Figure 4-16: Typical ICV characteristic line with two speeds | 85 |
| Figure 4-17: Running points chosen for a fan unit without control system (Vialle & al., 2007) | 88 |
| Figure 4-18: Running points chosen for a fan unit with constant pressure control system (Vialle & al., 2007) | 88 |
| Figure 4-19: Running points chosen for a fan unit with constant air flow rate control system (Vialle & al., 2007) | 89 |
| Figure 5-1: End of life fate of material of residential ventilation products installed in 2005 | 104 |
| Figure 5-2: Environmental impact of residential ventilation products installed in 2005, energy, water and waste | 105 |
| Figure 5-3: Environmental impact of residential ventilation products installed in 2005, emissions to air | 106 |
| Figure 5-4: Environmental impact of residential ventilation products installed in 2005, emissions to water | 106 |
| Figure 5-5: End of life fate of material of all residential ventilation products in 2005 | 107 |
| Figure 5-6: Environmental impact of all residential ventilation products in 2005, energy, water and waste | 108 |
| Figure 5-7: Environmental impact of all residential ventilation products in 2005, emissions to air ... | 108 |

| | |
|---|-----|
| Figure 5-8: Environmental impact of all residential ventilation products in 2005, emissions to water | 109 |
| Figure 6-1: Efficiency of different motors, courtesy EbmPapst..... | 114 |
| Figure 6-2: Efficiency of motors according to lot 11 | 115 |
| Figure 6-3: Constant pressure fan characteristic | 118 |
| Figure 6-4: Variable speed fan characteristic..... | 119 |
| Figure 7-1: Comparison of performance and efficiency characteristics of a standard and improved ICV | 124 |
| Figure 7-2: Comparison of performance and efficiency characteristics of a standard and improved ICV | 124 |
| Figure 7-3: LCC curve of DV not hood | 127 |
| Figure 7-4: LCC curve of an ICV with all options..... | 127 |
| Figure 7-5: LCC curve of an ICV if part load options are neglected | 128 |
| Figure 7-6: LCC curve of a DV-hood | 128 |
| Figure 8-1: Comparison of the average EEI @ PL values (three points displaying the EEI of 2, 6 and 12 for the average size product) and energy consumption of products showing some consistency and leaving room for two classes of grading under average (the red line indicates the E/F border set at average value); DV means local ventilation, ICV means central ventilation here..... | 136 |
| Figure 8-2: History of measures leading to the transformation of the market in the direction of the LLCC, applied to the average size product, for easiness of understanding..... | 144 |
| Figure 8-3: Share of market (according to estimates limited to products on the scope only (excluding collective ventilation) affected by MEPS proposed | 147 |
| Figure 8-4: Impact of MEPS proposed applied to products on the scope only (excluding CCV)..... | 151 |
| Figure 8-5: Comparison of the average EEI PL values and energy consumption of products showing some consistency and leaving room for two classes of grading under average | 153 |

LIST OF TABLES

| | |
|---|----|
| Table 1-1a: Different aspects and locations of decentralised ventilation fans (used for local ventilation) and their technical characteristics..... | 13 |
| Table 1-2a: Hoods compared with other decentralised ventilation fans and their technical characteristics | 13 |
| Table 1-3: Prodcom segmentation for ventilators | 18 |
| Table 1-4: Residential ventilation, energy performance standards | 23 |
| Table 1-5: SFP classes in W/(m ³ /s), from standard EN 13779..... | 28 |
| Table 1-6: Presentation of the test results at minimum flow rate conditions - example, UK building code (SAP, 2005) | 29 |
| Table 1-7: Presentation of the test results at minimum flow rate conditions - exemple, UK building code (SAP, 2005) | 30 |
| Table 1-8: NF VMC, minimal range of operation for a product to be qualified within the NF VMC.. | 30 |
| Table 1-9: Criteria for ENERGY STAR Qualified Residential Ventilating Fans – Minimum Efficacy Levels | 34 |
| Table 2-1: Production of Hoods (29.71 – 15.50) according to prodcom..... | 37 |
| Table 2-2: National Input/Ouput of Hoods 29.71 – 15.50 for year2005 | 39 |
| Table 2-3: Manufacturing of fans under 29.71.15.30 (that will be considered now as ventilation fans) | 40 |
| Table 2-4: Sharing the 2005 EU production of products under 29.71.15.30 according to number of recently constructed dwellings | 41 |
| Table 2-5: German sales of ventilation products, (TZWL, 2007) | 42 |
| Table 2-6: Market sales of residential centralized mechanical ventilation products in France, from (Uniclimate, 2007) | 43 |
| Table 2-7: Ventilation equipment rate of individual housing in France, from (ATEE, 2006) | 44 |
| Table 2-8: Ventilation equipment rate of individual and collective housing in France, from (ATEE, 2006)..... | 44 |

| | |
|---|-----|
| Table 2-9: UK sales of ventilation products in 1998, source BSRIA extracted from (Radgen, 2002) . | 45 |
| Table 2-10: Number of extractor fans observed in dwellings. | 45 |
| Table 2-11: Number of extractor fans observed in dwellings split by dwelling type. | 46 |
| Table 2-12: Characteristics of the EU heated area, residential sector – source (VHK Lot1, 2006)..... | 48 |
| Table 2-13: Default values of technical shares of ventilation system types to model the EU stock of ventilation fans in EU single dwellings (excl. collective)..... | 48 |
| Table 2-14: Default values of technical shares of ventilation system types to model the EU stock of ventilation fans in EU collective dwellings..... | 49 |
| Table 2-15: Adjusted technical shares of ventilation system types to model the EU stock of ventilation fans in EU single dwellings (excl. collective)..... | 50 |
| Table 2-16: Adjusted values of technical shares of ventilation system types to model the EU stock of ventilation fans in EU collective dwellings..... | 50 |
| Table 2-17: Adjusted estimate of the stock of distributed ventilation fans in use in number of units in EU-25 in 2005 | 51 |
| Table 2-18: Adjusted estimate of the stock of centralised ventilation fans in use in number of units in EU-25 in 2005 | 51 |
| Table 2-19: Adjusted estimate of sales data | 52 |
| Table 2-20: Projections to 2025, penetration of mechanical ventilation in new dwellings – individual houses | 55 |
| Table 2-21: Projections to 2025, penetration of mechanical ventilation in new dwellings – collective housing | 56 |
| Table 2-22: Projections to 2025, stock estimate EU 25 | 57 |
| Table 4-1: Bills of material of various fans for residential ventilation | 71 |
| Table 4-2: Bills of material of various fans as percentages of total mass | 74 |
| Table 4-3: Computing energy consumption, characteristics of operation – constant or variable load.. | 75 |
| Table 4-4: Computation of scenarios in options A (given conditions) and B (best efficiency point)... | 85 |
| Table 4-5: Reference total pressures for pressure controlled extract devices (Vialle & al., 2007) | 88 |
| Table 4-6: Possible of part load flow rates and frequency | 92 |
| Table 4-7: Progression of testing at part load..... | 94 |
| Table 4-8: Computation of options A – scenario 1 (SFP at given conditions) and B –scenario 4 (Efficiency at BEP) for some products in our data base..... | 95 |
| Table 5-1: Average energy consumption by product (DV & ICV) | 99 |
| Table 5-2: Average energy consumption by product (CCV) | 99 |
| Table 5-3: Summary of input for the environmental impact analysis | 100 |
| Table 5-4: Summary of the environmental impacts of base cases, total environmental impact and energy use..... | 102 |
| Table 5-5: LCC of base cases | 103 |
| Table 5-6: Environmental impact of residential ventilation products installed in 2005, energy, water and waste | 104 |
| Table 5-7: Environmental impact of residential ventilation products installed in 2005, emissions to air | 105 |
| Table 5-8: Environmental impact of residential ventilation products installed in 2005, emissions to water | 106 |
| Table 5-9: Environmental impact of all residential ventilation products in 2005, energy, water and waste..... | 107 |
| Table 5-10: Environmental impact of all residential ventilation products in 2005, emissions to air .. | 108 |
| Table 5-11: Environmental impact of all residential ventilation products in 2005, emissions to water | 109 |
| Table 5-12: Total electricity consumption of residential ventilation, EU 25 2005 | 110 |
| Table 5-13: Total environmental impact of the stock of ventilation fans between 2005 and 2025..... | 111 |
| Table 6-1: BOM of an improved motor according to lot 11 | 114 |
| Table 6-2: BOM of a standard motor according to lot 11 | 115 |
| Table 6-3: BOM comparison from lot 11 | 115 |
| Table 7-1: Improvement potential of the different residential ventilation products..... | 122 |
| Table 7-2: LCC input and results of decentralised ventilation products | 123 |

Table 7-3: LCC variations of ICV with different options 125

Table 7-4: LCC variations of a hood with different options 126

Table 8-1: Efficiency classes proposed for consistency of grading of residential ventilation fans based on EEI at Part Load (the EEI is shown for the average size product) 137

Table 8-2: Efficiency classes proposed for consistency of grading of residential ventilation fans based on EEI at Part Load (the product EEI is rounded to the closest integer)..... 139

Table 8-3: Date of measures if $Y_0=2009$ 144

Table 8-4: Assumptions made to compute the effects of measures taken on products on the scope only (not CCV)..... 149

Table 8-5: Results obtained the effects of measures taken on products on the scope only (not CCV) 150

Table 8-6: Benefits for the individual consumer of the measures in terms of unitary electricity consumption -products in the scope only (not collective ventilation of residential buildings) 150

Table 8-7: Benefits for the individual consumer of the measures in terms of LCC -products in the scope only (not collective ventilation of residential buildings)..... 150

Table 8-8: Benefits on total electricity consumption of scenarios for products on the scope only (excluding CCV) 151

Table 8-9: Benefits on total electricity consumption of scenarios for products on the scope only (excluding CCV) 152

Table 8-10: Benefits on total electricity consumption of products on the scope only (excluding CCV) 152

1 Definition of product, standards and legislation

According to the MEEuP methodology, *this task should define the product category and define the system boundaries of the 'playing field' for ecodesign. It is important for a realistic definition of design options and improvement potential (Task 7) and it is also relevant in the context of technically defining any implementing legislation or voluntary measures (if any) (Task 8).*

1.1 Product category and performance assessment

1.1.1 Product definitions

Ventilation fans ensure air renewal in occupied dwellings; it is necessary for three reasons:

- **comfort and hygiene for occupants (fresh air...),**
- **durability of the building (avoid odours and moisture condensation on surfaces inside dwelling),**
- **safety (face to combustion devices for example),**

Structure of ventilation systems and values of air flow rates are the result of Member States national building codes and national traditions. The requirement for fresh air flow has important energy consequences because of forcing cold air inside in winter and hot air inside in summer. Nevertheless, the thermal consequences and energy consequences is faced by different measures at building thermal envelope level implemented by Member States national building codes and the Energy Performance of Buildings Directive 2002/91/EC. Following the Article 15, alinea 2.c of the EuP directive 2005/32/EC, it can be said that the Community addresses this issue. As a consequence, the heat or coolness consequence of residential ventilation seems beyond the scope of the study. The study will so focus only on the efficiency of residential ventilation fans regarding their main duty, which is to provide fresh air for hygienic purpose. Some MS also require or recommend several airflows in dwellings (i.e. base, boost...) and therefore some control of the airflows. The study will take these features into account because they determine the product, but our work is about the product itself.

Building ventilation can be roughly divided into three categories: **natural ventilation, local mechanical ventilation (room by room) and central mechanical ventilation (various rooms)**. Each kind of ventilation requires specific energy using products. Mechanical ventilation includes all the motorized devices used to renew the indoor air. Hybrid ventilation systems are defined in EN12792 (under discussion for modification) as "ventilation where natural ventilation may be at least in a certain period supported or replaced by powered air movement component" to enlarge the notion not only to fans but to the full building which has to be designed in a certain way. Mechanical ventilation is associated to the presence of fans. The required energy using products for ventilation are shortly described hereafter respecting the three main types of ventilation

A ventilation fan consists of a bladed rotor that is connected to an electric motor through a shaft or a belt. The rotor can be preceded or followed by a stationary blade row and the ventilator can be linked to inlet and outlet ducts. In the domain of ventilation the fan and the motor are sold together, whether they are linked by a shaft or by a belt. Ventilators performances are characterized by the pressure and the airflow they can provide along with the required input power. These performances vary importantly among the vast amount of existing ventilators, a first segmentation (technical) is usually performed regarding how the air flow is deviated by the device, (Cory, 1992). Tangential fans may be called crossflow. The variety of shapes of blades is developed in a technical annex.

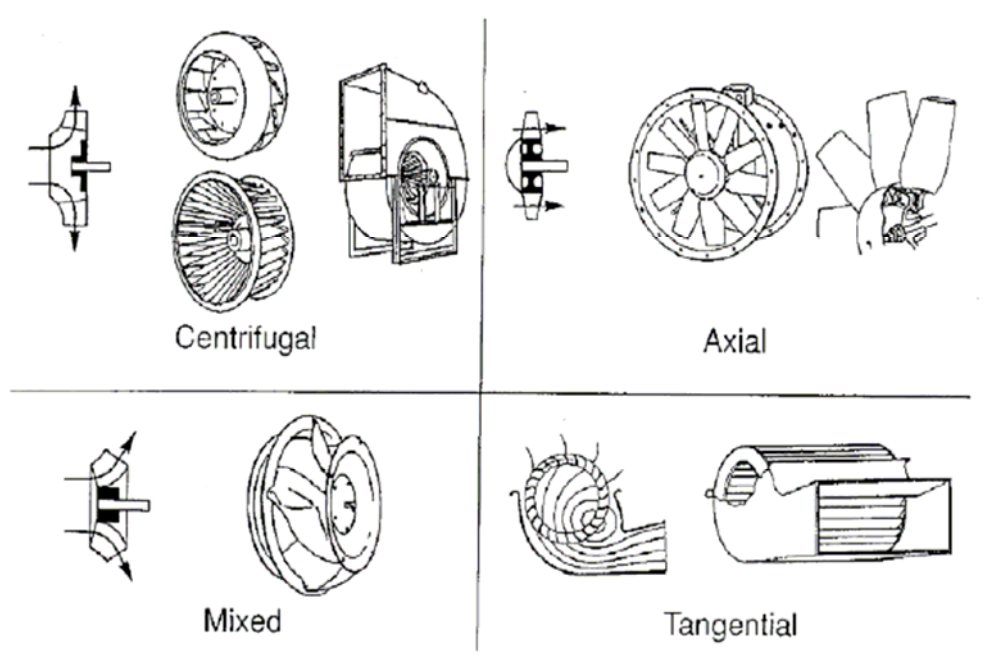

Figure 1-1: Different types of fans according to fluid mechanics, from Cory (1992)

Generally speaking, axial and centrifugal fans are the most frequent technical types. A propeller is an axial fan with few blades, designed to operate through a partition. For small fans, which are the most frequent in residences ventilations, the dominant rotor will be centrifugal (with either **forward or backward** curved blades) and the dominant motor an asynchronous AC motor. However there are some **EC** (Electronic Commutation) motors and some **DC** motors.

1.1.1.1 Natural ventilation (also called passive stack ventilation)

The air enters the dwelling through cracks, windows, slots and exits through vertical ducts. Each room of the dwelling or a set of rooms is equipped with vertical ducts and no ventilation device is required. Air motion is due to the difference between indoor and outdoor temperatures and to the wind pressure on the building shell. As a result, air renewal varies with climatic conditions and can be very insufficient in summer when the temperature difference between indoor and outdoor temperature is low or when there is no wind. Further status of natural ventilation depends on national building construction codes; UK offers the possibility to design natural ventilation whereas mechanical ventilation is mandatory in France¹. Natural ventilation is not an EuP, nor a performance option since the choice between types of ventilation is regulated by Member States through national building codes, hygiene regulations, etc. Specialists usually separate the notion of airing (through manual window opening) from the notion of natural ventilation which is "designed" or "predictable" (see EN12792), with a designed system (including natural ventilation passive stack or automatic window opening on some criteria)

1.1.1.2 Mechanical ventilation as opposed to natural ventilation

According to most countries building codes, the electricity consumption of a well balanced and tuned mechanical ventilation is limited compared with thermal energy saved by avoiding the direct effect of the wind in a poorly designed natural ventilation. Thermal energy used in buildings as a result of artificial or natural ventilation represents 30 to 40 % of heating demand in residential buildings (CFP,

¹ Mechanical ventilation is mandatory in France in all new dwellings since 1982 and in case of retrofit since 1969 in France according to (Ebm-Papst, 2006) and (Uniclimate, 2006)

2006) (as much as 80 % in some non residential buildings). Ventilation related electricity, heating and cooling demand calculation has been improved in each country in the EPBD frame.

From now on, the study will speak only of the EuP under consideration (the fan in charge of mechanical ventilation) and of its electricity consumption.

1.1.1.3 Decentralised (local) mechanical ventilation

The ventilation system can be designed as such as to generate underpressure in the rooms (general case) or over pressure.

Decentralised mechanical ventilation means that several extraction ventilators are used to renew the air of a complete house (without designed transfer between rooms in the dwelling). Three configurations are possible, as described by lot 11: a natural air supply with mechanical extract with fans, a mechanical air supply with natural extract (Positive insufflation ventilation, forbidden in some countries for dwellings due to the risk of pushing humidity in the walls), a mechanical air supply with mechanical extract. “Fan assisted” has been used in lot 11 for “mechanical”.

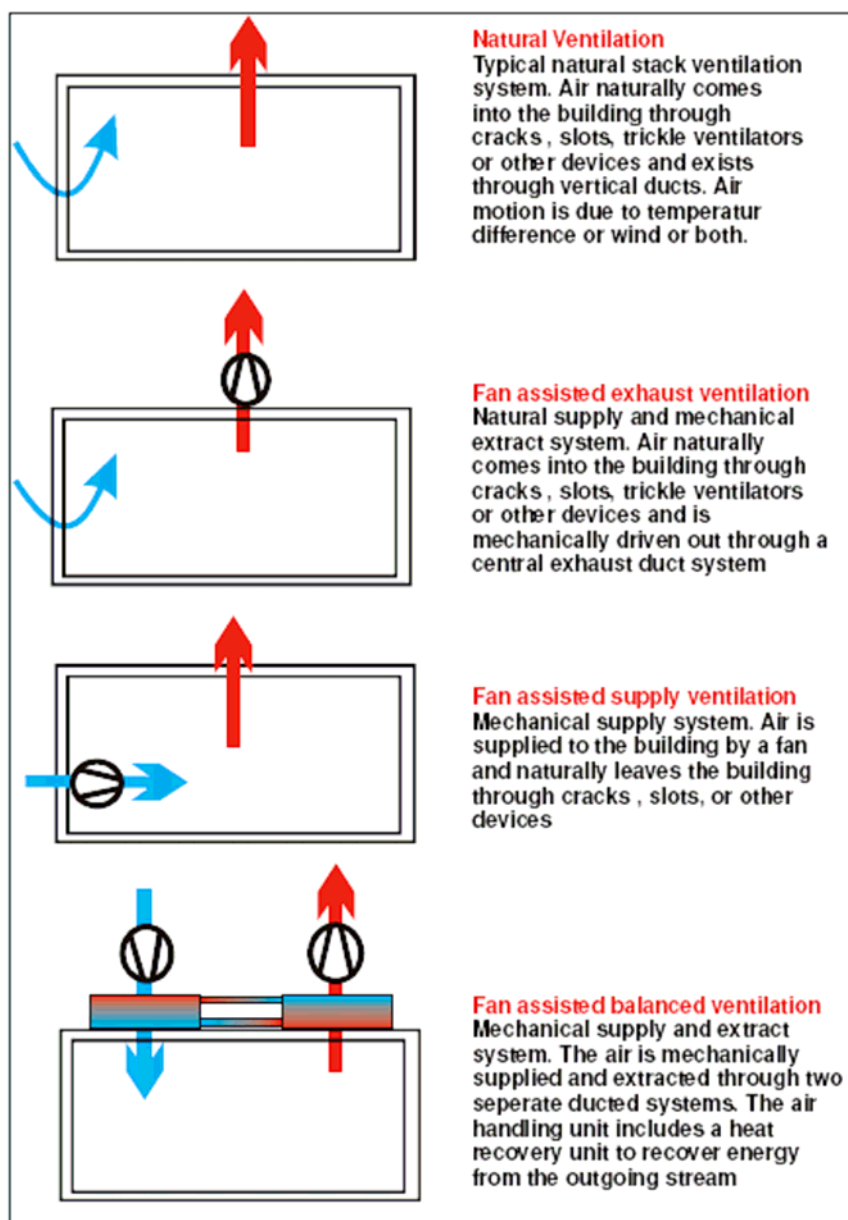

Figure 1-2: Different types of building ventilation, extract from Lot 11 study on ventilation in non residential buildings (Radgen, 2007)

The second configuration of figure 1.2 is by far the most common in Europe among the three fan assisted systems. The air comes into the room through cracks, windows, slots (natural air supply) and the stale air is evacuated by small sized fans or by hoods that can be located on the roof, the ceiling, the walls or in the windows. These fans also generate a depression enabling the outside air to naturally come into the room. For other configurations, fans can also be used for direct introduction of outside air inside, the fans used in this case are similar to the others. Residential ventilation fans usually include the motor, as opposed to larger power fans, they are tested under specific standards (EN 13141 parts 4 and 6 and CEI/IEC 61 591) and provide lower pressure differences, as we will see.

The decentralised mechanical ventilation can use fans with different locations and aspects, as seen from outside:

- **Roof fans** are located on the roof of the room or may be linked to a ducted system.
- **Extraction fans** can eject the air through the walls or the ceiling directly or through a short duct. Extraction fans are located inside whereas roof fans are located outside.
- **Window fans** are embedded in a window glass. They can also be located in the frame of the window (see Table 1-1).
- In the residential sector, **hoods** are located close to pollution sources (in the kitchen). The user can turn it on or off when he wants. Three different types of hoods can be found. The hood may be simply a frame and a filter to be plugged on a centralized ventilation system when authorized by the regulation (in France connecting a mechanical hood on the ventilation system of a building is forbidden due to fire protection law and hygiene law). In that case, there is no specific consumption for this product, which is not considered in this study. The hood can be plugged directly outdoor: polluted air is extracted inside and rejected directly outside; this is a decentralized ventilation system to be considered in this study. The third type is the assembly of a fan and a filtration system that filters indoor air and rejects it in the same room, typically above the hood, to be classified in the category air purifiers, not ventilation fans.
- There is a ventilation mode in “single-duct” air conditioners, that is studied in that lot, because the purchasing and using rationale is different.

In all categories, the fact they are ducted or not is translated by type A,B,C,D in ISO5801:

Type (A), free inlet, free outlet;

Type (B), free inlet, ducted outlet;

Type (C), ducted inlet, free outlet;

Type (D), ducted inlet, ducted outlet

Among decentralised systems, one finds the very common roof fans, window fans, etc. Roof fans (touvelles) refers to free discharge fans installed on roof, and can be centralized, local or even assistance for passive stack. A roof fan is represented in the figure 3.



Figure 1-3: Roof fan implantation scheme (Cory, 1992)

The figure 4 below shows that internally, it combines the motor and the fan itself. For decentralised systems, the ducts are short, as shown in the figure below, if any.



Figure 1-4: Roof fan figures from (Cory, 1992)

Coming to kitchen (or range) hoods, four (at least) geometries of kitchen hoods can be seen as distinct from outside, as in figure 5. The “bottom-of-the-market” hoods (“under cabinet”) are less expensive today.

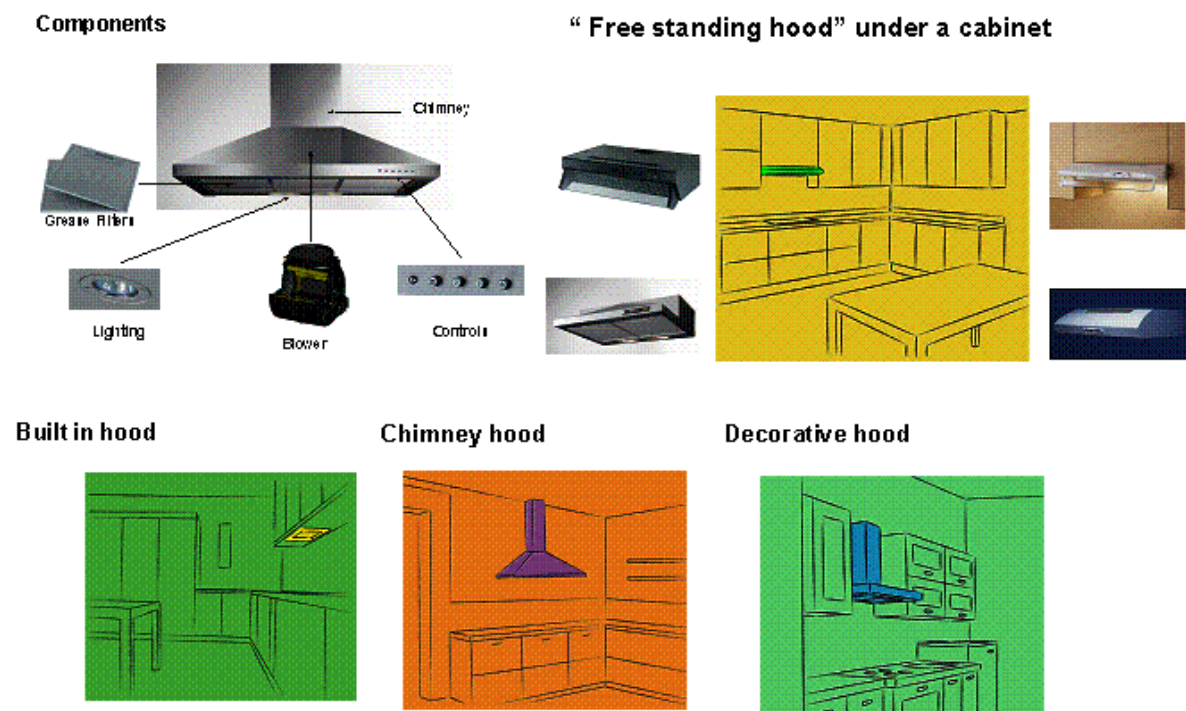

Figure 1-5: appearance of kitchen hoods (courtesy of manufacturers, 2008)







| Type | Operating scheme | Typical characteristics | Example |
|----------------------------------|---|---|--|
| Window glass |  | <ul style="list-style-type: none"> - Consumption: 20 – 100 W - Airflow: 200 – 1400 m³/h - Non ducted - Usually axial - Fix |  Helios |
| Window (Inside the frame) | Another type of window fan, located in the frame of the window | <ul style="list-style-type: none"> - Consumption: 120W - Reversible air flow - Non ducted - Usually axial - Movable |  Honeywell |
| Wall/ceiling |  | <ul style="list-style-type: none"> - Consumption: 10 – 50 W - 100 – 400 m³/h - Connected to a short ducted system - Usually axial - Fix |  Atlantic |
| Roof |  | <ul style="list-style-type: none"> - Often connected to a ducting system - Centrifugal or mixed fan - Outside the building |  |

Table 1-1a: Different aspects and locations of decentralised ventilation fans (used for local ventilation) and their technical characteristics

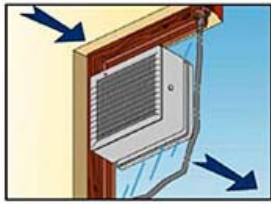
| Type | Operating scheme | Typical characteristics | Example |
|--------------|---------------------------|---|--|
| Hoods | Air extraction in kitchen | <ul style="list-style-type: none"> - Consumption: 100 – 300 W - Airflow: 200 – 1000 m³/h - Ducted - Usually centrifugal - Fix |  Vortice |

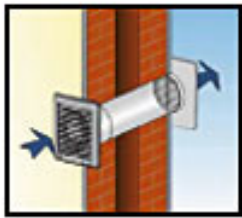
Table 1-2a: Hoods compared with other decentralised ventilation fans and their technical characteristics

1.1.1.4 Central mechanical ventilation

Centralized mechanical ventilation means that one extractor and a ducted system are used to renew the air of a whole dwelling (made of several rooms).

Three configurations can be found in the residential area: a natural air supply with mechanical extract, a mechanical air supply with natural extract and a mechanical air supply together with a mechanical extract.

Single extract centralized mechanical ventilation (Natural air supply and mechanical extract)

Because of the depression generated by the extractor, the air comes through the dwelling from the less polluted rooms (bedrooms, living rooms) to the most polluted ones (kitchen, toilets) by spaces around the doors, mostly under the doors. The air comes into the dwelling through cracks, windows, slots. Extract air is sucked by the extractor, evacuated by openings from the most polluted rooms. In terms of energy using products, this kind of ventilation requires an extractor larger than small sized fans (as defined in the previous subsection “local ventilation”). An extractor consists generally in a centrifugal fan driven by an asynchronous motor.

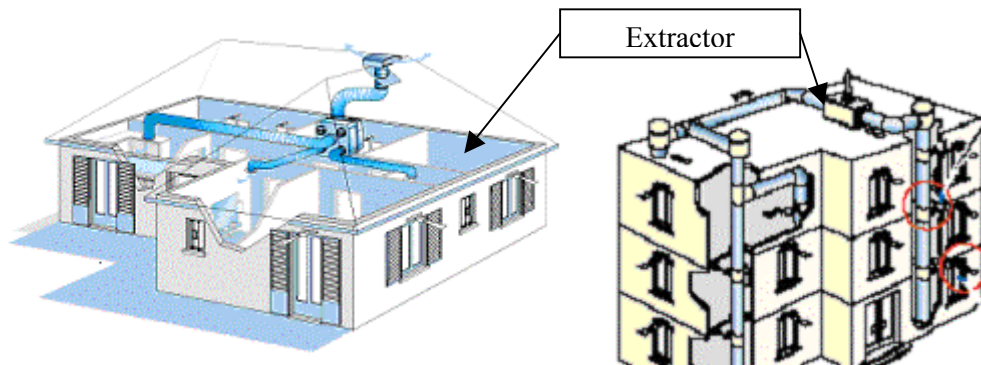

Figure 1-6: Centralized ventilation with natural air supply and mechanical extract fans, Atlantic (left: individual house, right : collective dwellings)



Figure 1-7: Simple flow extractor, Atlantic (left: individual house, right : collective dwellings)

Usually the electric power is under 80 W for individual houses and under 500W for collective dwellings ventilation.

In mechanical ventilation balanced systems or positive input ventilation (PIV), the air supply is sometimes made through a **ground coupled air to earth heat exchanger**, also called Canadian well, which allows partial cooling of the air in summer. In that case, mechanical ventilation can help to

decrease room temperature by a few degrees in summer. This system is designed by specialists on a case by case basis, built and buried on site.

Simple flow centralized mechanical ventilation (Mechanical air supply and natural extract)

Air is supplied centrally by a supply fan. Because of the overpressure generated by the air supply inside the dwelling, the air exits the dwelling through cracks, windows, slots.

Balanced double flow ventilation system

The double flow balanced system is made with (following the flow): air collection (outside the building), one fan, air inlets into the room, extraction devices, another fan, air extract device, with typically the addition of a heat exchanger and some filters, and ducts to conduct air flows (inlet and exhaust). The flow becomes almost independent from outside pressure conditions. The internal pressure balance becomes even more important.



Figure 1-8: Balanced double flow ventilation unit, Courtesy Swedish manufacturers

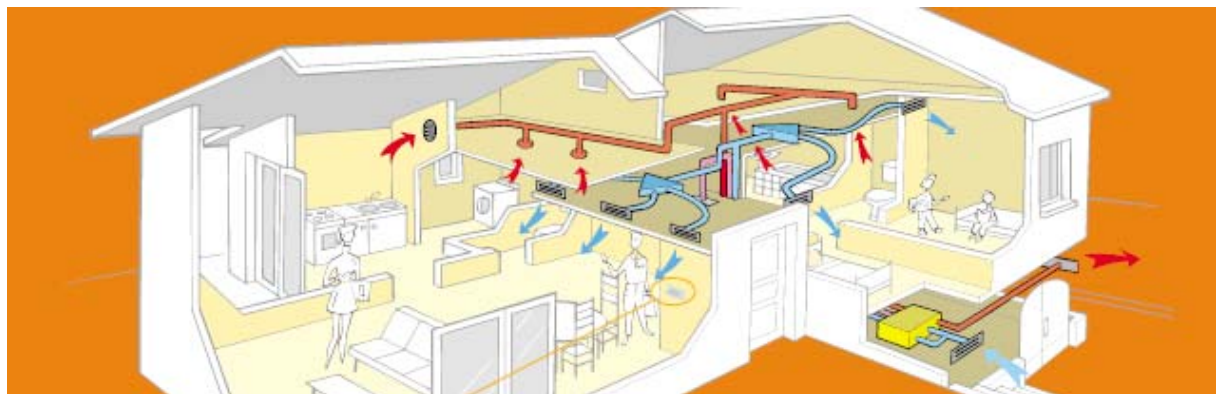



Figure 1-9: Balanced double flow ventilation system and unit, Courtesy Aldès -CFP

- **Balanced or Double flow centralized mechanical ventilation:** the extract air is extracted in the kitchen, the toilets and the bathrooms. New air is introduced in other rooms with another network but the same extractor block.
- Centralization allows to process the new air (filtration, heating, humidification...) and by gathering the two networks (extraction of stale air and extraction of new air) to preheat the new air by recovering heat on the extracted air thanks to a plate heat exchanger. As a result, double flow ventilation coupled **with heat recovery heat exchanger** enables to economize heating energy. This system enables to recover an important part of the energy lost because of the introduction of fresh air for ventilation need in winter but increases electricity use in the product. Double flow heat recovery ventilation is generally a stand alone product to be installed on the ventilation network in dwellings. The head losses being different, the electricity use cannot be compared directly with the other products.
- Centralized mechanical ventilation systems can become the basis of a reversible heat pump system that uses extract air as the cold source in winter and as the hot source in summer. This space heating system can be called “**balanced flow thermodynamic ventilation**”. It supplies both cooling in summer and heating in winter but the heating and cooling energy does not enable to cover all the heating and cooling needs because ventilation air flow rates are quite small. As for plate heat exchanger, heat or cool recovered will depend on outside conditions. This system enables to recover from 50 % to 200 % of the energy lost because of the introduction of fresh air for ventilation need in winter and in summer according to (Promotelec, 2006). Both in cooling and heating modes, this system can only supply part of the thermal requirements of a standard dwelling. It is covered by EPBD consistent national prescriptions and should be compared with other heating equipment like boilers.

Fan assisted natural ventilation (also called hybrid ventilation)

Natural ventilation may fail to deliver proper air renewal all year long particularly when wind outdoor is low. In those conditions, assisted natural ventilation makes use of a fan to maintain required hygienic flow rates. Typical flow rates of 300 m³/h and 10 to 20 W are common for these products. The appearance of fan assisted natural ventilation fan is showed on the figure below.

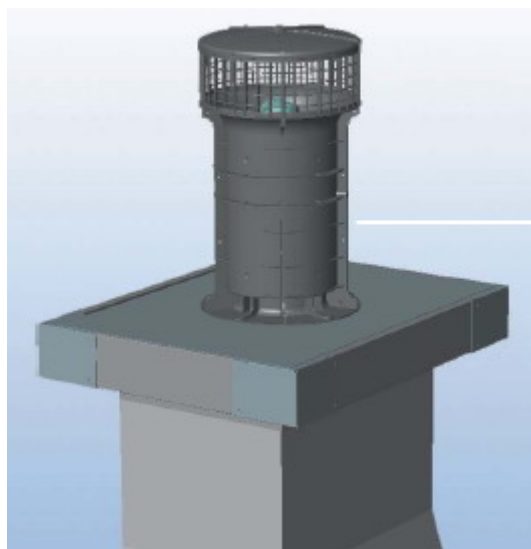

Figure 1.1-10: Passive stack fan assisted natural ventilation, Courtesy Aereco www.aereco.fr

1.1.2 Existing product categorisations

In the **Prodcod** inventory, ventilation fans are covered both by PRODCOM 29.23 (“Manufacture of non-domestic cooling and ventilation equipment”) and PRODCOM 29.71 (“Manufacture of electric domestic appliances”). Categories within PRODCOM 29.23 are meant for non residential products and mainly rely upon the type of fan (as presented in the first section of this study: centrifugal, axial...) with an electrical input lower limit of 125 W. Categories within PRODCOM 29.23 are thus not useful in our study of residential ventilation.

| Fans covered by PRODCOM 29.23 (“Manufacture of non-domestic cooling and ventilation equipment”) | |
|--|--|
| 29.23.20.30 | Axial fans (excluding table, floor, wall, window, ceiling or roof fans with a self-contained electric motor of an output ≤ 125 W) |
| 29.23.20.70 | Centrifugal fans (excluding table, floor, wall, window, ceiling or roof fans with a self-contained electric motor of an output ≤ 125 W) |
| 29.23.20.70 | Fans (excluding table, floor, wall, window, ceiling or roof fans with a self-contained electric motor of an output ≤ 125 W) |

| Fans covered by PRODCOM 29.71 (“Manufacture of electric domestic appliances”) | |
|--|--|
| 29.71.15.30 | Table, floor, wall, window, ceiling or roof fans, with a self contained electric motor of an output ≤ 125 W |
| 29.71.15.33 | Roof ventilators |
| 29.71.15.35 | Other ventilators |
| 29.71.15.50 | Ventilating or recycling hoods incorporating a fan, with a maximum horizontal side ≤ 120 cm ² |

² The indication about size is not present in the other languages than english and should be understood as an indication not a category limit since there is no category for the hoods that would happen to be larger

Table 1-3: Prodcum segmentation for ventilators

Within PRODCOM 29.71 one finds the residential products. We eliminate here 29.71.15.30, because we treat separately the comfort fans and we finally recognise the products under study in the present report under the three remaining categories. However note that products over 125 W are covered by PRODCOM 29.23 and that we have not included that category. All products over 125 W have been treated in lot 11, residential ventilation fans together with non residential, in consistency with PRODCOM statistics. The scope of recommendations of the present report will be limited to residential ventilation fans under 125W and to all kitchen hoods (a separate PRODCOM category), but we will not delete the results that we will gather or generate that may be useful for the study of residential ventilation fans over 125W.

Categories according to EN- products standards, namely testing standard EN 13141

Part 4 is applicable to encased ventilation fans having several inlets, as well as ducted and non ducted fans, without defining them more precisely.

Part 6 defines Exhaust ventilation system packages used in a single dwelling

A package is perfectly defined in the standard (two extents):

ventilation system package (for a single dwelling)

Combination of compatible components which are tested, delivered and installed as specified by the manufacturer to complete a residential ventilation system when sold as a single product.

exhaust ventilation system package

System package comprising all components necessary to complete at least the exhaust part of a ventilation system in a dwelling.

Part 7 defines a mechanical supply and exhaust ventilation unit (including heat recovery) for mechanical ventilation systems intended for single family dwellings as

In general such a unit contains:

- supply and exhaust air fans;
- air filters;
- air to air heat exchanger with/without air to air heat pump for exhaust air heat recovery;
- control system.

Such equipment can be provided in more than one assembly, the separate assemblies of which are designed to be used together.

Part 8 defines an un-ducted mechanical supply and exhaust ventilation unit (including heat recovery) for mechanical ventilation systems intended for a single room

In general, such a unit contains:

- supply and exhaust air fans;
- air filters;
- air to air heat exchanger for exhaust air heat recovery;
- control system.

Such equipment can be provided in more than one assembly, the separate assemblies of which are designed to be used together.

Categories according to EN- systems standards, namely terminology standard EN 12792

The present report has used the distinction coming from that standard (extract air refers to extraction from the room, exhaust refers to rejection outside)

“Air Terminal Devices” is a general name for products that one may call occasionally grilles, inlets, outlets, extracts, ... The definition is :

Air Terminal Device (ATD) : component of the installation which is designed with the purpose of achieving the predetermined movement of air into or from a treated space.

They can be :

automatically controlled : devices having moving parts which interact with a change in local conditions, such as temperature, humidity, CO₂ concentration, pressure difference, air flow rate, etc.

fixed : devices without any adjustable parts

manually adjustable : devices having adjustable parts which can be manually adjusted

Range hoods follow a distinct wording :

air extraction cooker hood : cooker hood which discharges the collected air to the outside of the building.

- air recirculating cooker

- hood

- cooker hood containing filters to remove contaminants after which the treated air is recirculated to the room (see also cooker hood)

1.1.3 Functional analysis

The primary function of ventilation fans is generally to **change indoor air** of a room or dwelling and the corresponding **functional parameter is the air flow rate**. To perform this function the system has to generate a certain pressure difference that is intrinsically related with the flow and so is part of the primary function. However this pressure difference varies between countries and is different from one product to another.

Double flow systems with heat recovery or thermodynamic double flow systems, have respectively two and three additional primary functions:

- double flow with heat recovery: change indoor air, recover heat;
- thermodynamic double flow: change indoor air, recover heat, recover coolness.

Hoods provide far more primary functions than other decentralized ventilation products : grease removal from the extract air, lighting of the working plan, etc.

Given that we already mentioned that the thermal consequences of residential ventilation were already addressed by other Community legislation³, we will not consider further the other (thermal) functions of double flow mechanical ventilation and thermodynamic double flow ventilation. However, the product displaying those thermal aspects will have more head losses, and two fans, which will lead to higher electricity use. We shall try to base our calculations on the ventilation function, by correcting for the other functions.

For this study, we are interested in products, motor, shaft or belt, fans, including the packaging if any, but not in the system, Air Terminal Devices, extracts, fresh air grilles and connecting ducts for instance for centralized systems; they will affect the product environmental impact but are not considered inside the EuP product in the rest of the study.

Thus, the product to be considered are individual mechanical extract fans for centralized or decentralized residential mechanical ventilation as defined previously:

- Fans for decentralized mechanical ventilation:
 - o Roof fans,
 - o Window fans,
 - o Wall fans,
 - o Hood fans.
- Fans for centralized ventilation
 - o Extract fan,

³ Please refer to paragraph 1.1.1.

- Supply fan,
- Extract and supply (balanced or double flow),
- Extract and supply (balanced or double flow) with heat recovery.

In Appendix 2 of lot 11 report many variables and parameters that can be considered are listed. From the physical point of view common to lot 10 and lot 11, there are two characteristics that can be considered as the primary functional parameters of a fan :

- the increase in pressure of the gaseous flow⁴ (Δp)
- the velocity of the flow (m³/s).

Apart from the two characteristics mentioned above there are a lot of other technical issues that have to be considered when selecting an appropriate fan. However they are clearly secondary.

The most important ones are:

- Diameter of the fan (m)
- Volume and weight of the fan
- Type of the fan (axial/centrifugal, backward/forward-inclined etc.)
- Type of drive and electrical supply
- Noise level and vibration
- Control systems
- Mounting arrangements and inlet/outlet sizes.

Can we choose between the two characteristic parameters? The existence of two functions (flow and pressure requested by the network and the other conditions) is the basis of the divergence between national building codes, which have specified national values. Furthermore they have taken distinct strategies to adapt to part load conditions. Our challenge here is to characterize the efficiency of the products (all products) in a way that does not contradict such national specifications.

The air flow rate and the pressure difference generated will be kept as main functional parameters. They are related by a curve that is obtained through testing and giving the air flow rate for a certain level of difference, and vice versa.

Scope proposal

Limitation to residential (individual ventilation fans, since collective are in lot 11) leads to the following scope proposal:

- Fans for decentralized (local) mechanical ventilation with or without HR:
 - Roof fans (Elec power < 125 W)
 - Window fans (Elec power < 125 W)
 - Wall fans (Elec power < 125 W)
 - Hood fans (remaining in the residential domain, like in the PRODCOM)
 - 'Decentralised' ventilation includes 'local ventilation' and kitchen ventilation by hoods
- Fans for central ventilation serving various rooms, which can be differentiated between fans serving one individual house (Elec power < 125 W) treated here and fans serving various dwellings in the same collective building (see lot 11); those products are also called encased fans and may be sold alone or as packages with the extracts and/or supply grilles, the roof outlets and/or inlets.
 - Extract fan, including assistance fans in hybrid ventilation

⁴ EN 13141-4 indicates in definition 3.1 that total (dynamic) pressure is to be considered when referring to the pressure difference between the two sides of a fan; IEC 61 591 uses the same definition (part 11)

- Supply fan
- Extract and supply (balanced or double flow).
- Extract and supply (balanced or double flow) with heat recovery.

1.2 Test Standards

This task should (EuP methodology):

Identify and shortly describe

- *the harmonised test standards;*
- *and additional sector-specific directions for product-testing.*

regarding the test procedures for:

- *the primary and secondary functional performance parameters mentioned above;*
- *resources use (energy, water, paper, toner, detergent, etc.) and emissions (NOx, CO, particulate matter) during product-life;*
- *safety (gas, oil, electricity, EMC, stability of the product, etc.);*
- *noise and vibrations (if applicable);*
- *other product specific test procedures.*

Apart from mentioning these standards, including a short description, it should also be reported which new standards are being developed, which problems (e.g. regarding tolerances, etc.) exist and what alternatives are being developed. Furthermore, the (ongoing) work on an ecodesign-standard, mandated by the European Commission to standardisation bodies, should be considered.

1.2.1 Energy use

Main EU standards applicable to ventilation products are gathered in the table below. The main test standard is the EN 13141 standard, except for kitchen hoods which have their own very consistent standard. Standards with potential impact on the design of the products are also reported.

| ISO test standard |
|---|
| ISO 5801 : test method for fans ;European standards below refer to this one |
| EU test standard |
| EN 13141, Ventilation for buildings - Performance testing of components/products for residential ventilation |
| <ul style="list-style-type: none"> - Part 1: Externally and internally mounted air transfer devices – May 2004. - Part 2: Exhaust and supply air terminal devices, Sept 2004. - Part 3: Range hoods for residential use – Apr 2004. - Part 4: Fans used in residential ventilation systems – Apr 2004. - Part 5: Cowls and roof outlet terminal devices - Jan 2005. - Part 6: Exhaust ventilation system packages used in a single dwelling - Apr 2004. - Part 7: Performance testing of mechanical supply and exhaust ventilation units (including heat recovery) for mechanical ventilation systems used in a single dwelling - Sept 2004. - Part 8: Performance testing of un-ducted mechanical supply and exhaust ventilation units (including heat recovery) for a single room, May 2006. - (Project) Part 9: humidity controlled air inlet, Oct 2006. - (Project) Part 10: hygrometric air outlet, Oct 2006. - (Project) Part 11: Positive pressure ventilation systems. |
| EN 13142, Ventilation for buildings - Components/products for residential ventilation - Required and optional performance characteristics |
| The performance characteristics of the components/products for residential ventilation are given in EN 13142. This document specifies the performance characteristics (required or optional) of components/products which may be necessary for the design and dimensioning of residential ventilation systems so that the predetermined conditions of comfort in terms of air change, temperature, speed, moisture and noise in the occupied area are guaranteed. We can say it's a summary of the core outputs of each of the preceding standards, except that it defines in addition what should be marked on the product. We should investigate if this marking can be used for energy efficiency characterization. |

| |
|---|
| Other relevant standards about general ventilation |
| Definitions |
| ISO/DIS 21220: Particulate air filters for general ventilation -- Determination of the filtration performance |
| EN 12792, Ventilation for buildings – Symbols, terminology and charts - Dec 2003. |
| EN13779 : non residential performance of ventilation systems (inc : SFP, filters...) |
| Design of ventilation systems |
| FD CEN/TR 14788, Ventilation for buildings – Design and sizing of ventilation systems for single dwellings, Aug 2006. |
| EN ISO 13790, Thermal performance of buildings, Calculation of heating needs, November 2004. |
| EN 832, Thermal performance of buildings, Calculation of heating needs for single dwellings, Aug 1999. |
| PrEN 15665, Ventilation in buildings - Determining performance criteria for design of residential ventilation systems |
| EN15242 and 15241 : energy and airflow calculations for ventilation (EN13790 refers to it for the ventilation part) |
| CEI/IEC 61 591 test standard for household range hoods |
| CEI/IEC 61 591 : household range hoods – methods for measuring performance |

Table 1-4: Residential ventilation, energy performance standards

EN 13141, Ventilation for buildings - Performance testing of components/products for residential ventilation

The content of each part of the standard is described shortly hereafter.

Part 1- Externally and internally mounted air transfer devices

It concerns externally and internally mounted air transfer devices, operating under pressure differences and used in mechanical ventilation systems and natural ventilation systems. They are passive components, and set boundary conditions for the product under consideration. They may be self adjusting inlets (that will limit the flow to the strictly necessary minimum), but there is not a figured limit to define when the word “self adjusting” is applicable or not. It only defines the measurement of head losses as a function of air flow curves. This leaves to national regulations or standards to set the limits to distinguish “self adjusting” devices.

Part 2: Exhaust and supply air terminal devices

It is another “passive” component of the system but connected to the product under consideration by a duct. It is operating under pressure differences, either in mechanical ventilation systems and natural ventilation passive systems. It may be self a adjusting device (corresponding to a design air flow), but here again there is not a limit to define when the word “self adjusting” is applicable or not. We only defines the measurement of head losses as a function of air flow curves. This leaves to national regulations or standards to set the limits to distinguish “self adjusting” devices.

Part 3: Range hoods for residential use

Here is defined the test method and conditions for range hoods for residential use which are “passive” components, not using electricity by themselves but using the depression generated by the energy using product via a duct. The information obtained is the flow generated when a certain depression is created. Here we may find boundary conditions for our product use.

Part 4: Fans used in residential ventilation systems

This part defines the test conditions for fans used in residential ventilation systems; it specifies aerodynamic, acoustic and electrical power performance test methods for encased fans used in residential ventilation. These methods primarily concern:

- ventilation fans installed on a wall or in a window without any duct;

- ventilation fans installed in the downstream of a duct;
- ventilation fans installed in the upstream of a duct;
- ventilation fans installed in a duct;
- encased ventilation fans having several inlets.

An important issue dealt with in the standard is the mounting of the various inlets and outlets, which can give origin to many combinations, mostly upstream of the flow.

Four categories of installations are defined in ISO 5801 and tested under this part 4:

- category A: Free inlet and free outlet;
- category B: Free inlet and ducted outlet;
- category C: Ducted inlet and free outlet;
- category D: Ducted inlet and outlet.

Then, all the products in the scope defined in part 1.1 are covered in this subpart of the EN 13141 test standard, including roof exhaust fans. This latter type of fan is normally installed at the downstream end of a duct and shall be tested using a category C or D installation. During the test, a simulation of the roof shall be used by installing the fan in a plate with a diameter at least three times larger than the fan inlet diameter. Fans with gravity controlled shutters can also be tested.

The classic SFP is a performance indicator (electricity consumed/ flow generated expressed in volume). SFP can be expressed in W/(m³/s) or in W/(m³/h) or in W/(l/s). In this part of the standard there is a non classic way of expressing performance: a massic, not volumic, SFP in that part:

$$y = \frac{P_F}{\rho \cdot q_v}$$

where

P_F is the mechanical energy (in J.kg⁻¹)

ρ is the inlet air density (in kg.m⁻³)

q_v is the volume flow rate (in m³.s⁻¹)

The most complete information that we obtain from this part 4 (and from which all the others derive) is the characteristic line of the fan (flow/pressure⁵ relationship). Then a calculation chain would be necessary to establish an energy performance index (examples will be given in part 4 of present document).

Part 5: Cowls and roof outlet terminal devices

This part aims at characterizing cowls and roof outlet terminal devices, the terminal products which are located outdoors to reject exhaust air. What is looked for is a negative impact of high winds on products.

Part 6: Exhaust ventilation system packages used in a single dwelling

Exhaust ventilation system packages used in a single dwelling in some way extends Part 4 by covering packages as opposed to encased fans, which is the core part of the package.

The practice of selling packages (with Air Terminal Devices), one per new individual house, seems frequent. The methods proposed later have to be applicable to the fan, with or without the ATDs. In collective housing, installers look also for consistency, but not for packages. Yet there is a degree of freedom in testing which is the length of the ducts, that this standard bounds for residential ventilation. So the main schemes determine the mounting of a full package like this one:

⁵ The standard uses the total (dynamic) pressure, not the static one; we are doing the same.

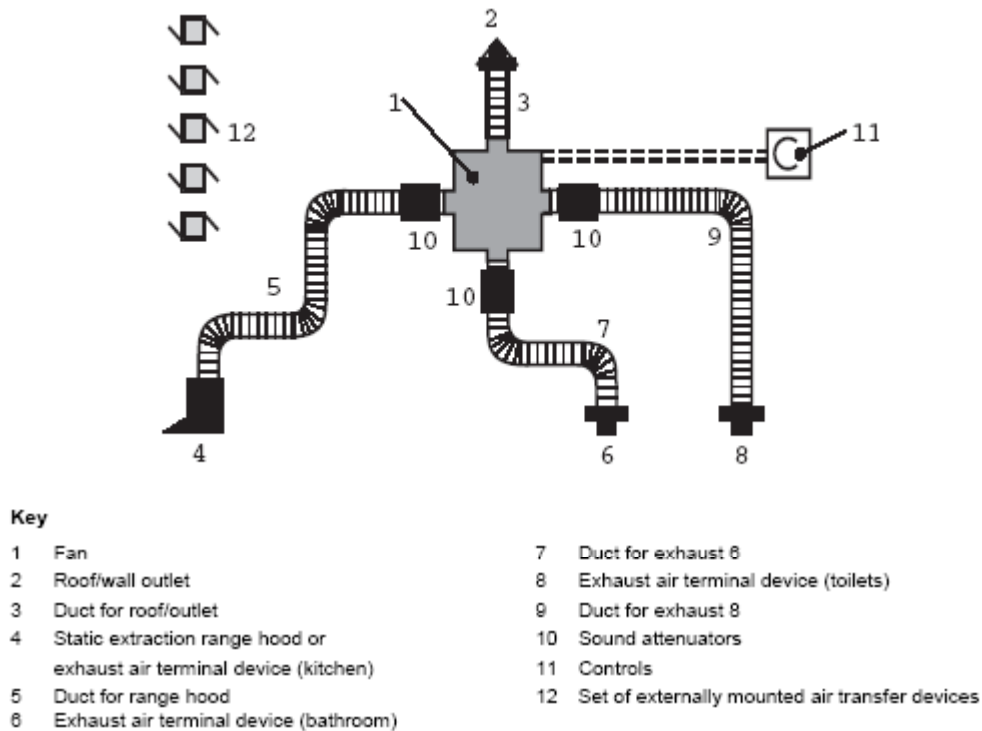

Figure 1-11: Standard scheme of a mechanical natural supply mechanical exhaust system

Such a package is the scope of an ecodesign measure due to the encased fan itself for individual houses. For collective housing, the performance indicators have to be limited also to the encased fan itself and its control.

Calculation outputs are the resulting flow (total and at each exhaust) and the power, for various conditions. Based on those ventilation performance indicators, an energy performance indicator like SFP could be computed, but outside of the standard. The nature of the exhaust device is not mentioned, namely if they are self adjusting or not. The number of exhausts is not limited. What is considered as the “worst” case in the standard is the worst case for flows, not for energy efficiency.

Part 7: Performance testing of mechanical supply and exhaust ventilation units (including heat recovery) for mechanical ventilation systems used in a single dwelling

Performance testing of mechanical supply and exhaust ventilation units (including heat recovery) for mechanical ventilation systems used in a single dwelling covers balanced flow equipment. In general such a unit contains:

- supply and exhaust air fans;
- air filters;
- air to air heat exchanger with/without air to air heat pump for exhaust air heat recovery;
- control system.

Such equipment can be provided in more than one assembly, the separate assemblies of which are designed to be used together.

This part does not deal with non-ducted units. See part 8.

Since there are two flows the use of SFP would be ambiguous and is avoided. What is mostly given is pressure / flow characteristic curves and heat recovery effectiveness (complex curves depending on temperatures, flow and controls). The method of testing for the performances of the heat pumps for heat recovery is generally given in EN14511 (energy) and in ENV 12102 (noise). EN13141-7 is being

revised at the moment to deal more correctly with Air-to-Exhaust Air balanced ventilation systems. Safety requirements are given in EN 60335-2-40 and EN 60335-2-80.

The standard for products with heat recovery (HR) is changing rapidly, and a new version is expected.

Part 8: Performance testing of un-ducted mechanical supply and exhaust ventilation units (including heat recovery) for a single room

Performance testing of un-ducted mechanical supply and exhaust ventilation units (including heat recovery) is about the same for a single room. There is no SFP or simple energy efficiency index proposed.

Part 9: humidity controlled air inlet

This part is about the inlets from outside to the ventilated room. Mostly passive components, they set boundary conditions for the product under consideration but do not generate a performance indicator for it. There is a good measurement of operation of humidity control but there is not a limit telling when the word “humidity control” is applicable or not. We only have the measurement of head losses / flow curves. This leaves to national regulations or standards to set the limits.

Part 10: hygrometric air outlet,

Same content as part 9 but for the component by which the extract air enters the duct on its way to the fan. Mostly passive components, they set boundary conditions for the product under consideration but do not generate a performance indicator for it. This part refers to part2 on all ATD for residential ventilation (fixed, self regulating..) and addresses the specific case of humidity controlled ATDs. There is a good measurement of operation of humidity control but there is not a limit telling when the word “humidity control” is applicable or not. We only have the measurement of head losses / flow curves. This leaves to national regulations or standards to set the limits.

EN 13142, Ventilation for buildings - Components/products for residential ventilation - Required and optional performance characteristics

The method of marking shall enable the identification of the product for handling by the installer and user.

Each product shall be marked with its characteristic parameters and the following information:

- manufacturer's or supplier's trade mark or identification mark;
- model or type number;
- voltage and electrical power consumption where appropriate.

Symbols specified for marking shall comply with the relevant International Standards.

The following additional characteristic values when given for individual products shall be indicated. They may be in accompanying literature, instructions, packaging, etc, which we know does not help end user choice or regulation checking.

- a) Externally mounted air transfer devices, internally mounted air transfer devices and exhaust air terminals
- free area;
 - nominal air flow rate and corresponding pressure difference;
 - whether closeable or non-closeable or pressure controlled;
 - acoustic performance.

NOTE: The nominal air flow rate and the corresponding pressure difference, or free area, may also be marked on the product.

Besides this last (facultative) option, it is not possible to base an ecodesign measure on such markings.

- b) Range hoods

- marked in accordance with EN 60355-2-31 (safety);
- nominal air flow rate;
- all parameters of integral filters;
- acoustic performance.

c) Fans

- marked in accordance with EN 60335-2-80 (safety);
- air flow rate/pressure performance;
- acoustic performance;

Something can be built on the pressure/flow characteristic curves, but it may depend on the boundary conditions (the demand, the terminal units).

d) Cowls and roof outlet terminals:

- pressure drop;
- free area;
- suction effect;
- performance of fan assisted cowls.

Not suitable for Ecodesign requirements definition since it's not an energy using product.

e) Ventilation system packages

Individual components shall be marked as if they were supplied as individual item. The following marking relates only to the package and shall appear only on labelling, manufacturer's literature and packaging.

- marked in accordance with EN 60335-2-80;
- air flow rate/pressure performance;
- acoustic performance;
- mechanical external and internal supply.

Speaking now of packages, the definition of usage classes and the indication of an efficiency of the package for each class becomes possible.

f) Mechanical exhaust and supply unit

- marked in accordance with EN 60335-2-80;
- leakage class, internal and external leakage;
- airflow rate/pressure performances;
- filter bypass leakage;
- temperature ratios;
- performance at low outdoor air temperature;
- acoustic performance.

Here again but energy efficiency can be defined.

Performance testing of non residential ventilation under EN 13779

PrEN 13779, Ventilation for non residential buildings – Performance requirements for ventilation and room conditioning systems **Note the words “non residential”**. However, if there are applicable ideas, they could be transferred into a new design standard for residential ventilation design.

This standard uses extensively the SFP concept. The classic SFP is a performance indicator (electricity consumed/ flow generated expressed in volume). SFP can be expressed in W/(m³/s) or in W/(m³/h) or in W/(l/s). In reality it's a pressure, something like the design pressure of the system, corrected for efficiency. The following classes have been introduced by the standard EN 13779:

| Class | Ratio, SFP in W/(m ³ /s) |
|-------|-------------------------------------|
| SFP 1 | < 500 |
| SFP 2 | 500-750 |
| SFP 3 | 750-1250 |
| SFP 4 | 1250-2000 |
| SFP 5 | 2000-3000 |
| SFP 6 | 3000-4500 |
| SFP 7 | >4500 |

Table 1-5: SFP classes in W/(m³/s), from standard EN 13779

This applies to an encased fan, as it is a subcase of Air Handling Units. The limitations of SFP are known: it depends on the pressure demanded. There is an original contribution in the revised version of EN 13779 under discussion: the extended SFP. The thresholds indicated previously are altered by adding a value for a filter, for a heat recovery unit, etc. So the AHU is compared with a threshold corresponding to about the same duty. This idea of a benchmark representing various levels of demand could clearly be transposed from the non residential systems into the most complex residential ventilation systems. An informative annex extends even more the idea by introducing an SFP extended to the full building.

CEI/IEC 61 591 : 2005 test standard for household range hoods

This standard applies to kitchen hoods, and covers many more aspects than the electricity consumption; however there is a reasonable consistence with the other ventilation products testing standards, in terms of definition of characteristic line. Indeed note 1 page 15 requests the full determination of that line, even if the standard extracts then one point out of that line, for a low pressure difference in fact. The air purifying filter is not in place during testing but the grease filter remains in place. We will discuss later the –limited – influence of the difference in performance measurement accuracy that can be originated by that fact.

This standard leads hoods manufacturers to generate a number of other informations important for our study : grease absorption efficacy, that could help to correct the characteristic line if the grease filter would be important; odour extraction efficacy, if we want to consider the recirculating hood, which is not the case here (we concentrate on ventilation hoods); effectiveness of the hob light, which is a real high level ratio of the output (illumination on the work plan) to the electricity consumption for lighting (including the source the luminaire the position of sources, a good practice example that may have been addressed in the lighting lot), noise level and some other features.

National testing standards

In most countries, the national standards derive from the international ones, as we will see. In the USA however there is an official testing standard self defined by the “private” certification body called HVI (Home Ventilating Institute). Document HVI 916 in its parts 5 and 6 describe the set ups and testing conditions for the products that will be later certified as Energy Star (see next part of present report).

National limits in EU countries for giving a certain “energy efficiency quality” to a product for the given EU country remain within the international standards but add boundary conditions, namely for centralized ventilation products.

In the UK, a supporting procedure for energy efficient ventilation products, the SAP- Appendix Q” was put in place in 2005, on behalf of the Energy Saving trust. It requests some testing definitions on top of EN 13141 specifications. We describe the version dated “July 2007” of the “Performance testing of products for residential ventilation - Central exhaust ventilation system packages used in a single dwelling”.

The UK builds explicitly on EN 13141-Part 6 by defining all missing data (duct lengths, elbows) like in the following graph:

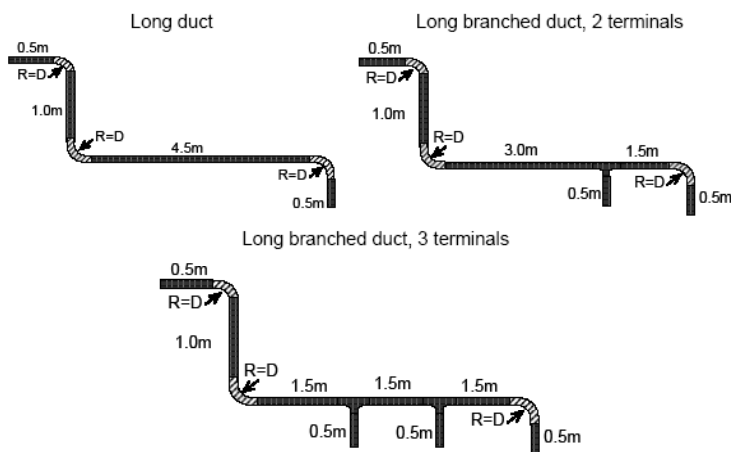

Figure 2 Examples of duct connections

Figure 1-12: Standard residential ventilation system as proposed in standard EN 13141 – Part 6 completed for the UK building code, from (SAP, 2005)

Since everything is specified, including the minimum flow demand, an SFP can be computed; this time it is expressed in W/(l/s):

| Exhaust terminal configuration | Fan speed setting | Total flow rate (l/s) | Specific fan power (W/l/s) |
|-----------------------------------|-------------------|-----------------------|----------------------------|
| Kitchen + 1 additional room | | | |
| Kitchen + 2 additional rooms | | | |
| Kitchen + .. Additional wet rooms | | | |

Table 1-6: Presentation of the test results at minimum flow rate conditions - example, UK building code (SAP, 2005)

The ducts can be rigid or flexible, and that makes a big difference in head losses (pressure drop). Both cases are covered here. The results obtained in the specified conditions are used for compliance both of the regular building code and for the efficient products promotion in the UK.

An extension of EN 13141- Part 7 for heat recovery products provides all the same functions in this (thermally) more efficient case. Bearing the same date it is called “Performance testing of products for residential ventilation - Central mechanical supply and exhaust ventilation system packages with heat recovery used in a single dwelling”. The table of results is extended accordingly:

| Exhaust terminal configuration | Fan speed setting | Total exhaust flow rate (l/s) | Total supply flow rate (l/s) | Specific fan power (W/l/s) | Temperatre ratio (%) |
|-----------------------------------|-------------------|-------------------------------|------------------------------|----------------------------|----------------------|
| Kitchen + 1 additional wet room | | | | | |
| Kitchen + 2 additional wet rooms | | | | | |
| Kitchen + .. Additional wet rooms | | | | | |

Table 1-7: Presentation of the test results at minimum flow rate conditions - exemple, UK building code (SAP, 2005)

In the UK, guidance for commissioning and installation is an interesting part of SAP documents.

We can find clear tolerances allowing to say whether an **air inlet is self adjustable** or not, in the NF VMC marking process (NF, 2007) in France. There are also clear tolerances allowing to say whether an **exhaust is self adjustable** or not, in the NF VMC marking process. It extends to **packages** which are said “**self adjustable**” or not as well. This marking is understood as a control of manufacturing stability, but includes technical specifications⁶.

An exhaust is said adjustable after a test comparable to EN 13141 Part 2. Another “passive” component but connected to the product under consideration by a duct. In the French test there is not a limit telling when the word “self adjusting” is applicable or not: the “self adjustment” pressure zone is the zone where the flow is maintained constant within -0%/+30% of the declared flow. For the declared pressures the flow should be constant within -0%/+30% of the declared flow. There are also a number of constraints for the ease and accuracy of mounting..



Figure 1-13: Certification logo of the French NF program for mechanical ventilation

This is then extended to the **full package, and applied to both speeds (usually only two speeds)**. Hereunder is reported the minimal zone to be covered to be within the NF VMC limits:

| | Kitchen | Air terminal device 15 m3/h | Air terminal device 30 m3/h |
|------------------|------------|--------------------------------|--------------------------------|
| Lower fan speed | 43.5 to 80 | 13 to 20 | 26 to 40 |
| Higher fan speed | ≥ 131 | 14.5 to 21.5 | 29 to 43 |

Table 1-8: NF VMC, minimal range of operation for a product to be qualified within the NF VMC.

Once again this puts transparency on the boundary conditions of our products and on its quality of answer to the needs, not on its energy efficiency. The same marking regulation puts also limits on noise, typically Lw under 37 dB(A).

What gives an information about energy efficiency is something coming next which builds on EN 13141 Part 6, without referring to it: a maximum electricity consumption at each speed, expressed in the ad-hoc unit of Watt ”Th-C”. For these tests the exhaust, ducts and rejection devices are completely specified. So what is at stake is really our EuP. In the configuration with two exhausts in restrooms, an extractor with one speed should respect $Pelec < 35$ W-Th-C. In the case where there are two speeds, first with three restrooms, $Pelec < 50$ W-Th-C, and then for two restrooms only, $Pelec < 35$ W-Th-C is requested to get the marking. Similar acceptance conditions are defined for each number of connected exhausts.

⁶ The marking regulation that was made available is dated from 2003 and refers to French standards preceding EN 13141.

What is Watt "Th-C"? It's the weighted average of the power demanded in a given configuration when all equipment are used at their normal flow and the power demanded in the same configuration when the end user activates the button in the kitchen (or elsewhere) demanding the highest possible flow in the kitchen. So it is really a part load energy efficiency indicator of high quality for our study. The weighting is 14 hours per week at large flow and the rest at normal flow in the French regulation (the 14 hours are reduced to 7 hours when there is an automatic reset of normal conditions in the product, an interesting option in our further work). Additional rules were defined and are currently applied to solve all the problems coming from the definition of such a part load indicator. If we do not find conflicting national values, we could keep those coefficients and rules for our technical study. We have to take into account SAP rules in doing so.

The results obtained in the specified conditions are used for compliance in the regular French building code Th-C, now version RT2005, previously version RT2000.

We can find also clear tolerances allowing to say an **air inlet is humidity controlled** or not in the French procedures. Also, there are clear tolerances allowing to say an **exhaust is humidity controlled** or not. Some specifications of **humidity control testing** are defined in a CSTBat document "Testing code ESSAIS-HYG", dated July 2003, serving as a basis for CSTBat "certification". It seems to build upon EN 13141 Part 9: humidity controlled air inlet, without saying explicitly (certainly because it's not published). It sets pressure differences values preferred for testing (20 Pa for inlets) and the acceptance limits. It adds some conditions to make the test more realistic. It takes a simpler testing installation than EN 13141 Part 4 but still consistent with ISO. CSTBat "certification" is understood by us as being a quality mark giving more confidence in the process of checking the application of French building code (a smaller penalty being applied on one term of the equations).



Figure 1-14: Certification logo of the French program CSTBat

French standards have been put in line with the EN standards that we just described. It should be said that there is one (higher) level of package testing practiced in France but which seems not yet under standardization in Europe: the humidity controlled package with a fan integrated control of moisture. The standard is called NF-E-51-706.

Installation

EN 14134, Ventilation for buildings - Performance testing and control of installation of ventilation systems in single dwellings - Aug 2004.

Requirements

EN 13142, Ventilation for buildings - Components/products for residential ventilation – Characteristics of mandatory and optional requirements, Août 2004.

1.2.2 Noise

There are ISO test standards for acoustic fan performance. Acoustic tests are described in all parts of EN13141 and CEI/IEC 61591&60704.

1.2.3 Safety

No specific standard reported

1.3 Existing legislation

1.3.1 Legislation and Agreements at European Community level

The effect of environmental directives (RoHS, WEEE, Packaging directive) has been investigated and no stakeholder reported any interaction with present study.

The new building regulations (e.g. developed under the Performance of Buildings Directive) will increase the share of products with double flow, so will increase electricity use in order to save thermal energy.

1.3.2 Legislation at Member State level

No product legislation has been indicated yet as being relevant by the Member States. Nordic countries have limited the SFP of ventilation systems, but this can be seen more as a building code than as a regulation of the product itself. We are aware of some features of French building code which are of the same nature, even if they use a different physical representation. When there are two speeds on a residential ventilation system, they use a “weighted average” of both electricity consumptions to build a performance index. French regulation admits 14 hours/week of high speed if the control is made directly by the user and 7 hours per week when it’s perfectly automatic (timer).

The French building code takes also into account the “certification” of components, i.e. the independent verification made of some key figures provided by the manufacturer, by giving a “bonus” to certified products. It’s the case for extractors, air vents, etc.

1.3.3 Third Country Legislation

This section again deals with the subjects as above, but now for legislation and measures in Third Countries (extra- EU) that have been indicated by stakeholders (NGOs , industry, consumers) as being relevant for the product group

ENERGY STAR Program Requirements for Residential Ventilating Fans (2006)

Below is the product specification (Version 2.0) for ENERGY STAR qualified residential ventilating fans. A product must meet all of the identified criteria to earn the ENERGY STAR.

US Definitions:

- **A. Residential Ventilating Fan:** A ceiling, wall-mounted, or remotely mounted in-line fan designed to be used in a bathroom or utility room, or a kitchen range hood, whose purpose is to move objectionable air from inside the building to the outdoors. Residential ventilating fans used for cooling (e.g., whole-house fans) or air circulation are excluded. Heat/energy recovery ventilation fans ducted to the ventilated space and powered attic ventilators (e.g., gable fans) are excluded, but may be considered in a future version of this specification. Residential ventilating fans with heat lamps are excluded from this specification. This specification does not address passive ventilation of any kind.

- **B. Combination Unit:** A residential ventilating fan that contains a light source for general lighting and/or a night light.

- **C. In-line Ventilating Fan:** A fan designed to be located within the building structure and requires ductwork on both intake and exhaust. Those in-line fans with only one intake are referred to as “single port” in-line fans, while those with multiple intake ports are referred to as “multi-port” in-line fans in this specification.

ENERGY STAR Specification Requirements for Qualifying Products: Only those products that meet the energy-efficiency criteria outlined in the table below, may qualify for the ENERGY STAR. This table is expressed in SFP terms (without using the name, and refer thus to an arbitrary pressure level for each product, which is defined by the certification body “Energy Star” in its document “Eligibility Criteria”. In opposition with the EN standard, the static pressure is used; not the dynamic (total) pressure. In a first approach, the demanded pressure differences may seem low compared with some EU situations, and consequently the demanded SFP may seem easy to reach. However the information is not enough to be certain of that.

| Criteria for ENERGY STAR Qualified Residential Ventilating Fans – Minimum Efficacy Levels | | | | | |
|--|--------------------------------|--|--|--|--|
| Airflow (cfm) | Minimum Efficacy Level (cfm/W) | Airflow (m ³ /h) | Minimum Efficacy Level W / (m ³ /h) | Minimum Efficacy Level W / (m ³ /s) | Static pressure difference selected for testing (Pa) |
| Range Hoods up to 500 cfm (max) | 2.8 | Range Hoods up to 850 m ³ /h (max) | 0.21 | 757 | 75 or else (according to speed) |
| Bathroom and Utility Room Fans 10 to 80 cfm | 1.4 | Bathroom and Utility Room Fans 17 to 136 m ³ /h | 0.42 | 1513 | 25 |
| Bathroom and Utility Room Fans 90 to 130 cfm | 2.8 | Bathroom and Utility Room Fans 153 to 221 m ³ /h | 0.21 | 757 | 25 |
| Bathroom and Utility Room Fans 140 to 500 cfm (max) | 2.8 | Bathroom and Utility Room Fans 238 to 850m ³ /h (max) | 0.21 | 757 | 25 |
| In-Line (single-port & multi-port) Ventilating Fans | 2.8 | In-Line (single-port & multi-port) Ventilating Fans | 0.21 | 757 | 50 |

Table 1-9: Criteria for ENERGY STAR Qualified Residential Ventilating Fans – Minimum Efficacy Levels

Other US legislation

Some of the ventilation standards have maximum energy requirements, and others leave the energy regulations to standards dedicated to energy use in buildings (LBL, 2005). The ventilation standards that have specific requirements for energy usage are the ALA Health House that specifies a maximum of 0.5 watt per cfm for exhaust fans, and 1 watt per cfm for HRV’s. Minnesota requires a maximum of 0.8 W per cfm for residential (constant air volume) systems. California Title 24 is an energy standard so it dictates that when mechanical ventilation is installed, the power of the fans is and the extra infiltration load is added to the building energy usage.

Task 1 summary

Products covered in the range of present report:

- Fans for decentralized mechanical ventilation with or without HR:
 - o Roof fans (Elec power < 125 W)
 - o Window fans (Elec power < 125 W)
 - o Wall fans (Elec power < 125 W)
 - o Hood fans (remaining in residential domain)
 - o 'Decentralised' ventilation includes 'local ventilation' and kitchen ventilation by hoods
- Fans for centralized ventilation serving various rooms, which can be differentiated between fans serving one individual house (Elec power < 125 W); those products are also called encased fans and may be sold alone or as packages with the extracts and/or supply grilles, the roof outlets and/or inlets.
 - o Extract fan, including assistance fans in hybrid ventilation
 - o Supply fan
 - o Extract and supply (balanced or double flow).
 - o Extract and supply (balanced or double flow) with heat recovery.

The existing EN 13141, Ventilation for buildings - Performance testing of components/products for residential ventilation, namely Part 4: Fans used in residential ventilation systems, is consistent with our categories. This part 4 defines the test conditions for fans used in residential ventilation systems except hoods; it specifies aerodynamic, acoustic and electrical power performance test methods for encased fans used in residential ventilation. It answers to our needs because it covers decentralized products (ventilation fans installed on a wall or in a window without any duct; in the downstream of a duct; in the upstream of a duct; installed in a duct) and centralized products called here encased ventilation fans having several inlets (and in common language extractors), without electric power limit. Part 6: Exhaust ventilation system packages used in a single dwelling extends Part 4 by covering packages as opposed to encased fans, which is the core part of the package. However the necessity to specify boundary conditions better led some countries (UK and France namely) to publish testing procedure based on this Part 6 but more complete. There is a lot of divergences on such additions. According to the present study, this is not the way to go if we want to characterize the product (almost) independently from the national building practices. The solution is in EN 13 141. EN 13141 is anyway under revision; it is important to take the following aspects into account:

- indicating that the control is part of the product, which could lead to some improvements
- introducing the efficiency calculation along the characteristic line, not only an arbitrary SFP value

CEI/IEC 61 591 : 2005 test standard for household range hoods applies to kitchen hoods, and covers many more aspects than the electricity consumption; however there is a reasonable consistence with the other ventilation products testing standards, in terms of definition of characteristic line. It determines also the effectiveness of the hob light, which is a real high level ratio of the output (illumination on the work plan) to the electricity consumption for lighting (including the source the luminaire the position of sources, and the noise).

The systems in present study will be named according to the ventilation system main type, Decentralised ventilation (DV) –including hoods- or Centralised ventilation (CV). However among centralised products we can immediately introduce the existence of products used in one or two dwellings that we will call Individual centralised Ventilation products (ICV) and products designed for more than two dwellings and called here collective (CCV). Among CV products some very small power products (a few Watt) are only used as an assistance to natural ventilation (passive stack ventilation) and will be called here HCV (for hybrid ventilation). They may be integrated in ICV. In all mechanical ventilation systems, DV, ICV and CCV, there is a possibility of association with heat recovery, which changes largely the demand in electricity of the fans in the products that we shall call then DV&HR, ICV&HR and CCV&HR. The analysis shows that the heat or coolness consequence of

residential ventilation seems beyond the scope of the study. Also the standard for products with heat recovery (HR) is changing rapidly, and a new version is expected.

2 ECONOMIC AND MARKET ANALYSIS

2.1 Generic economic data

According to the MEEuP methodology *this task is expected to reconstruct from Prodcum and other statistics: EU Production, Extra-EU Trade, Intra-EU Trade, Apparent EU-consumption in physical volume and in money units and split up per Member State.*

Production of hoods for years 1995 and 2005

We have had access to Italian CECED data of 1995, this country being the largest manufacturer of hoods (6 400 000) and small fans (1 600 000) at that time and today. Most of the production was exported (5 700 000 hoods) but 700 000 hoods were installed in Italy that year. However we don't know proportion ventilation and recycling hoods. Hoods used as a ventilation mean and hoods used in recycling mode are the same product: the decision on how to use the hood is made by the final user and the energy and resources use is the same in both situations, as well as the improvement possibilities. The main importers of Italian hoods were Germany (1 950 000), France (700 000), BeNeLux (430 000), UK (700 000), Spain (350 000), the total of exports to other EU countries being 4 600 000 units.

For the recent years the Prodcum series are rather complete. In 2005, Italy remains the main producer, now with 12 250 000 hoods at a declared cost of 50 Euros. Germany follows with 1 797 000 units (116 Euros) then Spain with 1 090 000 units (102 Euros) and Poland with 440 000 units (21 Euros). Many countries have declared their production figure confidential. The declared costs are so different that they correspond obviously to different stages of manufacturing. However the costs between 20 and 50 Euros and 100 Euros give an indication of manufacturing costs, before any commercial circuit. The prodcom data give imports, production and exports of hoods. But which share of the hoods is recycling (purification) and which share is extracting air to the outside (ventilation)? This remains unknown. We provide first (tables 2.1 and 2.2) gross and treated Prodcum figures and later (table 2.17) stock figures obtained by assuming that half of hoods installed in Europe are connected to the outside and so performing ventilation.

Table 2-1: Production of Hoods (29.71 – 15.50) according to prodcom

| | In'000 units | | | | | | | In min. Euro | | | | | |
|----------------------|--------------|------|------|------|-------|-------|-------|--------------|------|------|------|------|------|
| | 1995 | 2000 | 2001 | 2002 | 2003 | 2004 | 2005 | 2000 | 2001 | 2002 | 2003 | 2004 | 2005 |
| Italy | 6400 | 6895 | 9142 | 9622 | 12329 | 12726 | 12256 | 390 | 431 | 462 | 617 | 616 | 608 |
| Spain | | 1153 | 1137 | 999 | 1006 | 1063 | 1089 | 88 | 89 | 91 | 97 | 106 | 110 |
| Poland | | ? | ? | 339 | 246 | 363 | 441 | ? | ? | 5 | ? | 6 | 9 |
| Germany | | ? | ? | ? | ? | ? | 1797* | 156 | 164 | 170 | 167 | 185 | 209 |
| Exports EU 15 | 1100 | 2966 | 3134 | 3281 | 3504 | 4184 | 4322 | 181 | 203 | 232 | 250 | 296 | 327 |
| App.Cons. | 5300 | 7218 | 9281 | 9476 | 11874 | 11765 | 11261 | | | | | | |

* inferred

From these data with assumptions, we could edit in table 2.2:

- EU Production
- Extra-EU Trade (with the assumption that extra EU trade being proportional to total exports between the two largest EU producers) and Intra-EU Trade (with the assumption of intra EU imports being proportional to total imports)

- Apparent EU-consumption in physical volume and in money units and split up per Member State:
table 2.2.

Table 2-2: National Input/Output of Hoods 29.71 – 15.50 for year2005

| | In '000 units | | | | | | In min. Euro | | | | | |
|-------------|------------------|------------------|------------|----------|-------------|----------|------------------|------------------|------------|----------|-------------|----------|
| | Apparent Exports | Apparent Imports | Production | Imports | Consumption | Exports | Apparent Exports | Apparent Imports | Production | Imports | Consumption | Exports |
| | Intra + Extra | Intra + Extra | | Extra EU | | Extra EU | Intra + Extra | Intra + Extra | | Extra EU | | Extra EU |
| Austria | 46 | 140 | 0 | 21 | 94 | | 4 | 17 | 0 | 1 | 13 | |
| Belgium | 49 | 208 | 0 | 31 | 159 | | 11 | 22 | 0 | 1 | 11 | |
| Cyprus | 0 | 25 | 0 | 4 | 25 | | 0 | 2 | 0 | 0 | 2 | |
| Czech Rep. | 35 | 232 | 0 | 35 | 197 | | 3 | 12 | 0 | 1 | 9 | |
| Denmark | 68 | 241 | 3 | 36 | 176 | | 10 | 25 | 3 | 2 | 18 | |
| Estonia | 0 | 25 | 0 | 4 | 25 | | 0 | 1 | 0 | 0 | 1 | |
| Finland | 26 | 99 | 7 | 15 | 80 | | 3 | 7 | 2 | 0 | 6 | |
| France | 52 | 1277 | 0 | 191 | 1225 | | 7 | 83 | 0 | 6 | 76 | |
| Germany | 972 | 1280 | 1797 | 191 | 2105 | 498 | 164 | 79 | 209 | 5 | 124 | 74 |
| Greece | 110 | 297 | 0 | 44 | 187 | | 3 | 21 | 0 | 1 | 18 | |
| Hungary | 68 | 212 | 0 | 32 | 144 | | 0 | 6 | 0 | 0 | 6 | |
| Ireland | 1 | 95 | 0 | 14 | 94 | | | 11 | | 1 | 11 | |
| Italy | 8458 | 151 | 12256 | 23 | 3949 | 3393 | 594 | 2 | 608 | 0 | 16 | 217 |
| Latvia | 0 | 60 | 0 | 9 | 60 | | 0 | 4 | 0 | 0 | 4 | |
| Lithuania | 10 | 70 | 3 | 10 | 63 | | 0 | | 0 | 0 | | |
| Luxembourg | 0 | 11 | 0 | 2 | 11 | | 0 | 2 | 0 | 0 | 2 | |
| Malta | 0 | 4 | 0 | 1 | 4 | | 0 | 0 | 0 | 0 | 0 | |
| Netherlands | 295 | 533 | 0 | 80 | 238 | | 14 | 51 | 0 | 3 | 37 | |
| Poland | 718 | 422 | 441 | 63 | 145 | | 19 | 20 | 77 | 1 | 78 | |
| Portugal | 8 | 202 | 17 | 30 | 211 | | 0 | 16 | 1 | 1 | 17 | |
| Slovakia | 7 | 73 | 0 | 11 | 66 | | 0 | 4 | 0 | 0 | 4 | |
| Slovenia | 133 | 165 | 0 | 25 | 32 | | 6 | 8 | 0 | 1 | 2 | |
| Spain | 846 | 1096 | 1089 | 164 | 1339 | | 50 | 73 | 110 | 5 | 133 | |
| Sweden | 138 | 184 | 0 | 28 | 46 | | 14 | 17 | 0 | 1 | 3 | |
| UK | 216 | 1293 | 0 | 193 | 1077 | | 5 | 86 | 0 | 6 | 81 | |
| EU 25 | 12040 | 7102 | 15613 | 1062 | 11752 | 3891 | 907 | 569 | 1010 | 38 | 672 | 291 |

It is interesting to note that there has been a steady growth of exports of hoods from the 90's, but also a quick growth of internal use. This sector of range hoods is really an exporting sector and a sector concentrated in two (or maximum four) EU countries. The total of hoods sold from 1995 to 2005 (thanks to a linear interpolation) is around 90 million units, which can be seen as an image of the stock in use. By applying the same stock/market ratio, we will give in table 2.17 a value for the national stock of each country.

Production of fans for years 1995 and 2005

In principle there are ventilating fans sections in PRODCOM 29.71.15 separate from comfort fans and called:

- 29.71.15.33 Roof ventilators
- 29.71.15.35 Other ventilators

Generally the separate figures are not available. It is necessary to formulate a hypothesis about the way the MS use the categories provided by Prodcom and to assume that they practically merged into the general category:

29.71.15.30 Table, floor, wall, window, ceiling or roof fans, with a self-contained electric motor of an output <= 125 W

where ventilation is not indicated and where comfort fans imports are dominant.

The word “roof” in the general title of 29.71.15.30 can be seen as a reference to “roof ventilators” and justifies our assumption. The existence of a EU production under this item is also in favour of our assumption. In practical term, the hypothesis leads us to transfer from the comfort fans study to the ventilating fans study the EU production figures.

Table 2-3: Manufacturing of fans under 29.71.15.30 (that will be considered now as ventilation fans)

| | In'000 units | | | | | | In min. Euro | | | | | |
|-----------------|--------------|-------|-------|-------|-------|--------|--------------|---------|---------|---------|---------|---------|
| | 2000 | 2001 | 2002 | 2003 | 2004 | 2005 | 2000 | 2001 | 2002 | 2003 | 2004 | 2005 |
| Italy | 1716 | 1927 | 1062 | 2339 | 2338 | 2184 | 39,403 | 46,154 | 48,102 | 46,169 | 51,808 | 49,906 |
| Poland | 200? | 300? | 637 | 1059 | 1423 | ? 1800 | ? | ? | 3,758 | 6,963 | 8,485 | ? |
| UK | 3074 | 3014 | 2848 | 3897 | 3790 | 2707 | 105,412 | 101,171 | 95,114 | 96,834 | 105,222 | 95,715 |
| Portugal | 0 | 0 | 0 | 0 | 0 | 24 | 0 | 0 | 0 | 0 | 0 | 5,757 |
| Sweden | 171 | 168 | 181 | 0 | 0 | 0 | 12,820 | 12,841 | 14,095 | 0 | 0 | 0 |
| Spain | ?1500 | 1470 | 1483 | 1671 | 1641 | 1922 | ? | 18,993 | 19,613 | 18,293 | 20,273 | 20,470 |
| Germany | 4000? | 4000? | 4000? | 4000? | 4000? | 3859 | 198,221 | ? | 150,783 | 139,903 | 130,404 | 116,392 |
| TOTAL | 10661 | 10879 | 10211 | 12966 | 13192 | 10696 | 355,856 | 179,159 | 332,32 | 308,162 | 316,192 | 288,24 |

Procom data are sometimes available for “roof ventilators” and “other ventilators” and indicate for instance an Italian production for 1998 and 1999: 1 300 000 units with a unitary value of 27 Euros. It is very consistent with the figures that we obtain for 2000-2005 with our assumption. The fact that manufacturing takes place in UK, Germany and Spain is also confirmation.

Now that we have the production, how to estimate the “national share” of ventilation products (accounted for under 29.71.15.30 by “mistake”) purchased by each country? First we have to admit that the small fans are used in many sectors, and we assume half of them is in the non residential sector (small offices, workshops, etc). Then EU production is split according to the construction of recent buildings⁷ in table 2.4 below. Extra-EU Trade has been estimated as negligible in this analysis up to now, which is a weak point. In the following table we have admitted 33% exports⁸. Note that sales of hoods and other ventilation fans seem to be of the same order of magnitude, a point that is of importance for energy consumption calculation later.

⁷ Given by lot 1 study, corrected in the ventilation report, one exception is Portugal, where we assume national use of the few products manufactured recently

⁸ This figure corresponds to the export values that was problematic in the comfort fans report

Table 2-4: Sharing the 2005 EU production of products under 29.71.15.30 according to number of recently constructed dwellings

| Intra EU ~1000 | Dwellings 1990-2005 | Total from EU 25 | IT (From) | PL (From) | UK (From) | P (From) | E (From) | D (From) |
|----------------------|---------------------|------------------|-------------|-------------|-------------|-----------|-------------|-------------|
| Total to EU25 | 13213 | 4194 | 2200 | 1800 | 2700 | 24 | 1900 | 3900 |
| To : A | 345 | 109 | 19 | 16 | 23 | | 17 | 34 |
| To : B | 519 | 164 | 29 | 24 | 35 | | 25 | 51 |
| To : CY | 20 | 6 | 1 | 1 | 1 | | 1 | 2 |
| To : CZ | 187 | 58 | 10 | 8 | 13 | | 9 | 18 |
| To : DK | 119 | 38 | 7 | 5 | 8 | | 6 | 12 |
| To : EST | 13 | 5 | 1 | 1 | 1 | | 1 | 1 |
| To : FIN | 178 | 57 | 10 | 8 | 12 | | 9 | 18 |
| To : F | 1931 | 609 | 107 | 88 | 131 | | 93 | 190 |
| To : D | 1659 | 523 | 92 | 75 | 113 | | 80 | 163 |
| To : GR | 346 | 110 | 19 | 16 | 24 | | 17 | 34 |
| To : H | 197 | 61 | 11 | 9 | 13 | | 9 | 19 |
| To : IRL | 410 | 130 | 23 | 19 | 28 | | 20 | 40 |
| To : IT | 440 | 138 | 24 | 20 | 30 | | 21 | 43 |
| To : LT | 16 | 6 | 1 | 1 | 1 | | 1 | 2 |
| To : LIT | 41 | 13 | 2 | 2 | 3 | | 2 | 4 |
| To : LUX | 22 | 7 | 1 | 1 | 2 | | 1 | 2 |
| To : MT | 10 | 3 | 1 | 0 | 1 | | 0 | 1 |
| To : NL | 789 | 250 | 44 | 36 | 54 | | 38 | 78 |
| To : PL | 860 | 272 | 48 | 39 | 59 | | 41 | 85 |
| To : P | 655 | 230 | 36 | 30 | 45 | 24 | 31 | 64 |
| To : SK | 843 | 265 | 47 | 38 | 57 | | 40 | 83 |
| To : SLO | 48 | 15 | 3 | 2 | 3 | | 2 | 5 |
| To : E | 1421 | 449 | 79 | 65 | 97 | | 68 | 140 |
| To : S | 182 | 57 | 10 | 8 | 12 | | 9 | 18 |
| To : UK | 1961 | 619 | 109 | 89 | 134 | | 94 | 193 |

By extrapolating back to 1995 and summing up, we have obtained a stock/market ratio that we applied to get an estimate of national stocks from the Prodcom data, that we will give in table 2.17.

2.2 Market and stock data

The following data has to be gathered according to the EuP methodology:

In physical units, for EU-25, for each of the categories as defined in 1.1 and for reference years

- 1990 or 1995 (Kyoto ref.);
- 2003-2005 (most recent real data);
- 2010-2012 (forecast, end of Kyoto phase 1, relevant also for Stockholm, etc.);
- 2020-2025 (forecast, year in which all new eco-designs of today will be absorbed by the market).

the following parameters are to be identified:

- Installed base (“stock”) and penetration rate;
- Annual sales growth rate (% or physical units);
- Average Product Life (in years), differentiated in overall life time and time in service, and a rough indication of the spread (e.g. standard deviation);
- Total sales/ real EU-consumption, (also in €, when available);
- Replacement sales (derived);
- New sales (derived).

To our knowledge there is no European data basis similar to BSRIA or GFK data bases for air conditioners and other products. Some figures exist on a country by country basis and were treated as

follows. Unfortunately they only indicate the past trends, likely to be affected seriously by the Energy Performance of Buildings Directive 2002/91/EC.

In order to ease information exchange with stakeholders, it seemed useful here to clearly publish all the sources that have been used.

Some national data available

DTI, the leading **Danish** laboratory indicates that, according to the new energy provisions (the Building Regulations, Appendix 12), balanced ventilation is being installed in almost all newly built one-family houses, which gives the sales figures below for housing ventilation aggregates for Denmark (*source: Statistikbanken-StatBank, newly built housing in Denmark, the whole country*)

The building of residential housing (not adj. for delays). Number of dwellings according to their state, area, use and time

| | 2000 | 2001 | 2002 | 2003 | 2004 | 2005 | 2006 |
|------------------------------------|-------|-------|-------|-------|-------|-------|-------|
| Completed | | | | | | | |
| One-family houses | 5 345 | 5 173 | 4 987 | 6 296 | 7 445 | 8 548 | 8 626 |
| Terraced, linked and double houses | 3 678 | 4 289 | 5 063 | 7 443 | 7 339 | 6 736 | 6 054 |

We can add to that aggregates sold for one-family houses under renovation where ventilation is established (which is very much on the increase) and products used for maintenance. In blocks of flats where ventilation is most often carried out with central exhaust without heat recovery.

The **total Scandinavian market** has been estimated by one stakeholder to be around 650 000 units, likely without the hoods.

German market data generated by (TZWL, 2007) for 1999, 2002, 2003 from the German manufacturers are reproduced hereunder. The TZWL splits the “decentralised” solutions (we admit that they correspond to window, wall and roof fans) and the “centralised” solutions (real extractor fans). As suggested by the author they have been corrected due to the lack of 10% of sales in the statistics. Part of the so called “decentralised systems” are not used in residences, but we don’t know the proportion. This treatment gives the “corrected sales” hereunder that we consider completely underestimated, an impression to be checked from other sources.

| Germany | 1999 | 2002 | 2003 |
|---------------------------------|-------------|-------------|-------------|
| Uncorrected sales decentralised | 82500 | 116000 | 160000 |
| Uncorrected sales centralised | 62000 | 41000 | 30000 |
| Corrected sales decentralised | 91600 | 128800 | 177700 |
| Corrected sales centralised | 68800 | 45500 | 33300 |

Table 2-5: German sales of ventilation products, (TZWL, 2007)

For BeNeLux, one stakeholder indicated total yearly sales of 350 000 units, certainly without the hoods, likely ICV only.

In the Netherlands, the building code will have a strong influence now on the product under consideration in the present report. The consumption of the ventilating fans is taken into account with a default value, lower for direct current motors than for AC motors. There is at the same time a big pressure in favour of heat recovery systems, which increase the head losses, and thus the power demand.

Figure 2.1 hereunder (ENPER, 2006b) shows the evolution of the share of the various ventilation systems in newly built dutch buildings. The traditional systems were close from the traditional

exhaust, like in France. The percentage of double flow with heat recovery is reported to have grown from 0,5% in 1995 to 30% in 2002 and finally to 50% in 2003 on the total of buildings, not only residential. We will have to interpret this figure to estimate markets in residential ventilation in the future.

Figure 2-1: penetration of heat recovery in the Netherlands

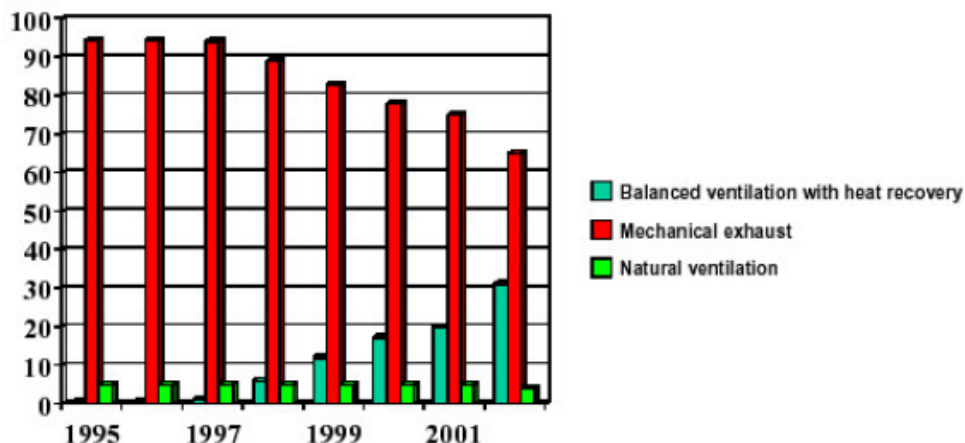

French market data figures generated by the manufacturers’ association (Uniclimate, 2006) are not corrected for exhaustiveness by including imports and excluding exports. However the manufacturers association gather most of the industry and the margin of uncertainty is less than 20%. Since centralised extraction is almost the rule in France now, we can estimate that we have a saturated market, and discover the renewal process.

| | 2004 | 2005 | 2006 | 2007* |
|--|-------------------------------|-------------------------------|-------------------------------|-------------------------------|
| Total ICV sales (usually extract) | 542 000 | 567 000 | 609 000 | 642 000 |
| ICV&HR sales | 3600 | 3800 | 5000 | 8600 |
| ICV and ICV&HR in new houses | 240 000 | 250 000 | 230 000 | 250 000 |
| ICV estimated in renovation and maintenance | <i>from 305 600 to 350000</i> | <i>From 320 800 to 358000</i> | <i>From 384 000 to 445000</i> | <i>From 400 600 to 465000</i> |
| DV** (renovation and maintenance) | 247 000 | 234 000 | 250 000 | 308 000 |
| CCV** (new and renovation) | 93000 | 100000 | 105000 | 114000 |
| CCV&HR** sales | 1100 | 1400 | 1700 | 2400 |
| number of new CCV dwellings | 187000 | 214000 | 209000 | 250000 |
| Same divided by 5 | <i>37400</i> | <i>42800</i> | <i>41800</i> | <i>50000</i> |

*inferred from first semester, our estimates are in italics

** includes non residential use

Table 2-6: Market sales of residential centralized mechanical ventilation products in France, from (Uniclimate, 2007)

One interesting figure more: one fourth of CCV have a belt, and the others a direct drive.

Coming to the stock of equipment in use in year 2005, a study conducted by Ademe/air.h (ATEE, 2006) indicates the following stock (number of products in use) in France:

- for individual houses,

| Housing - individual | Nb of dwellings (/1000) | % of dwellings |
|--------------------------------|-------------------------|----------------|
| No ventilation | 2405 | 14% |
| Nat. ventilation room by room | 6309 | 36% |
| Overall natural ventilation | 3760 | 22% |
| Mechanical ventilation | 4859 | 28% |
| Total ventilation (nat.+mech.) | 8619 | 50% |

Table 2-7: Ventilation equipment rate of individual housing in France, from (ATEE, 2006)

This indication is important because by comparing the flux of renovation equipment of table 2.6 and the stock of installed equipment, we find an apparent lifetime around 10 years.

- for collective housing,

| Housing - collective | Nb of dwellings (/1000) | % of dwellings |
|--------------------------------|-------------------------|----------------|
| No ventilation | 1155 | 9 % |
| Nat. ventilation room by room | 4451 | 34 % |
| Total natural ventilation | 2298 | 17 % |
| Mechanical ventilation | 5162 | 40 % |
| Total ventilation (nat.+mech.) | 7460 | 57 % |

Table 2-8: Ventilation equipment rate of individual and collective housing in France, from (ATEE, 2006)

Results of the tables 2.6 and 2.7 added are shown on the graph below.

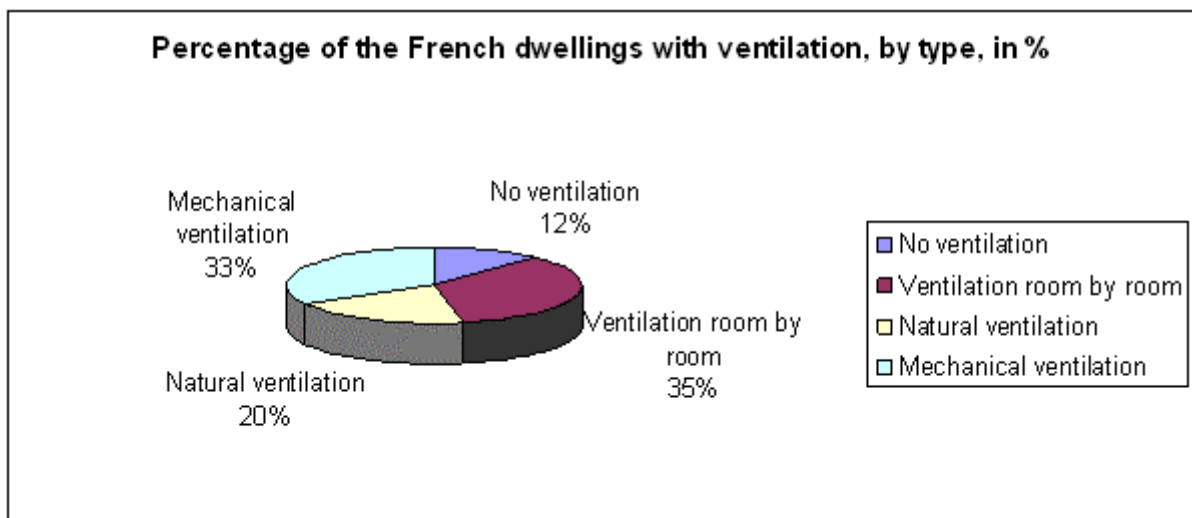

Figure 2-2: Ventilation equipment rate of individual and collective housing (total stock) in France, from (ATEE, 2006)

For the UK in 1998, BSRIA data reported by (Radgen, 2002) indicate the following sales:

| Product | Sales |
|------------------------|---------|
| Axial ventilator | 1400000 |
| Centrifugal ventilator | 180000 |
| Heat recovery units | 10000 |
| Cooking hoods | 550000 |

Table 2-9: UK sales of ventilation products in 1998, source BSRIA extracted from (Radgen, 2002)

Most dwellings would have one or no extract fans, and they would be switch-controlled (often linked to the lighting of an internal toilet). Continuous operation would be very rare for individual units.

Centralised systems will be mostly in older blocks of flats. Flats account for about 20 % of UK dwellings, and perhaps 60 % of them are in high-rise blocks. Of these, only municipal blocks (mostly built in the 1960s or 1970s) are likely to have centralised systems. So 10 % might be reasonable for pre-1990, but perhaps only 5 % for newer ones (new build has more flats, but they are less likely to be high-rise or municipally owned).

The number of electrically powered extractor fans in English dwellings has been examined, as observed by the 2003/04 (combined) English House Condition Survey. The survey identifies the presence of extractor fans in the kitchen, the bathroom and the WC, marking where a fan is present in each room. No other rooms are examined and the results should be interpreted as indicating the minimum number of extractor fans in a dwelling (as other fans may be present elsewhere in the dwelling, and the rooms that are examined may contain more than one fan). However, it reasonable to assume that these rooms are the most likely to contain extractor fans across the stock, and that few will contain more than one fan. A small number (2.7 %) of survey cases recorded missing / unknown data and it should be noted that these are included in the percentages below.

| Number of extractor fans | Number of dwellings | Percent of all dwellings |
|--------------------------|---------------------|--------------------------|
| 0 | 10,479,000 | 48.5% |
| 1 | 6,504,000 | 30.1% |
| 2 | 3,994,000 | 18.5% |
| 3 or more | 59,000 | 0.3% |
| Missing / Unknown | 578,000 | 2.7% |
| Total | 21,613,000 | 100% |

Table 2-10: Number of extractor fans observed in dwellings.

| Dwelling type | | Number of extractor fans | | | | | Total |
|-------------------|------------------------------------|--------------------------|-----------|-----------|-----|-------------------|------------|
| | | 0 | 1 | 2 | 3 + | Missing / Unknown | |
| House or bungalow | Number of dwellings | 8,898,000 | 5,436,000 | 3,098,000 | * | 489,000 | 17,954,000 |
| | Percent of all houses or bungalows | 49.6% | 30.3% | 17.3% | * | 2.7% | 100.0% |

| | | | | | | | |
|-------|--------------------------|------------|-----------|-----------|--------|---------|------------|
| Flat | Number of dwellings | 1,580,000 | 1,068,000 | 896,000 | * | 89,000 | 3659000 |
| | Percent of all flats | 43.2% | 29.2% | 24.5% | * | 2.4% | 100.0% |
| Total | Number of dwellings | 10,479,000 | 6,504,000 | 3,994,000 | 59,000 | 578,000 | 21,613,000 |
| | Percent of all dwellings | 48.5% | 30.1% | 18.5% | 0.3% | 2.7% | 100% |

* = Sample size too small for useful analysis.

Table 2-11: Number of extractor fans observed in dwellings split by dwelling type.

Our model of the stock in year 2005 at EU level

The systems in use are numbered hereunder according to the ventilation system main type, Decentralised ventilation (DV) or Centralised ventilation (CV).

For decentralised ventilation systems, the statistics have to represent the technical type of products:

- Roof fans,
- Window fans, Wall fans,
- Hood fans.

The same is true for Centralised ventilation products (CV). We have to separate the products used in one or two dwellings that we will call Individual Centralised Ventilation products (ICV) and products designed for more than two dwellings and called here Collective (CCV). Hybrid products (HCV) will be ignored here due to their insignificant market share.

In all systems, DV, ICV and CCV, there is a possibility of association with heat recovery, which changes largely the demand in electricity of the fans in the products that we shall call DV&HR, ICV&HR and CCV&HR.

In order to establish some values for countries with no specific statistics we generated default values. **An EU wide survey paper** presented at Clima 2007 (Ledean, 2007) gathers expert estimations about the use of various solutions of ventilation in some EU countries. There is a table for new buildings and a table for old buildings:

| | Finland | UK | NL | Denmark | Italy | Poland | France |
|-------------------------------------|-------------------------|----------|-----|---------|----------------|--------|--------|
| supply and exhaust | 90% (house), 30% (coll) | <1% | 60% | | Yes | 5% | 5% |
| exhaust only mechanical ventilation | 10% (house), 70% (coll) | <1% | 40% | flats | Yes, env 5%(5) | 7% | 95% |
| Natural ventilation | 0 | 40% | | houses | No | 87% | 0% |
| Local ventilation | 0 | 20% (1) | | | Yes | 1% | 0% |
| Airing (window) | 0 | 100% (3) | | | most common | - | 0% |

| | Finland | UK | NL | Denmark | Italy | Poland | France |
|-------------------------------------|-----------------------------|------------|-----|--------------------|-------------|--------|--------|
| supply and exhaust | 30% (house), 5% (coll) | <1% | 10% | | Few | 1% | 1% |
| exhaust only mechanical ventilation | 30% (house), 75% (coll) | around 10% | 50% | flats <15 year (4) | Yes | 5% | 40% |
| Natural ventilation | <40% (house (1)), 20 (coll) | 2% | 30% | houses | No | 93% | 19% |
| Local ventilation | <10% (house (2)), 0% (coll) | 20% (1) | 10% | | Yes | 1% | 30% |
| Airing (window) | 0 | 100% (3) | | flats >15 year (4) | most common | - | 10% |

(1) generally, kitchen hood and fan
 (2) generally fan in bathroom, hood+fan in kitchen
 (3) airing through window is always used for boost ventilation
 (4) over 15 years, no ventilation in dwellings
 (5) generally airing through window but more texts show the need of mechanical ventilation

Figure 2-3: Ventilation systems in new and existing buildings, from (Ledean, 2007)

This allows to share the stock of dwellings among technical solutions. After considering various sources of data, namely Impro⁹, we found that the data generated by Lot 1 about the age of the heated areas was the most convenient to translate ventilation fans penetration into numbers of fans. We extracted the following data from version 3 of task 2 report of Lot 1 (VHK Lot1, 2006).

| Country | Primary residences (1000) | 1 or 2 Dwell. | Multi | Years | | | | | | Floor Area (m2) |
|---------|---------------------------|---------------|-------|--------|-------------|-----------|-----------|--------|--------|-----------------|
| | | | | < 1919 | 1919 - 1945 | 1946-1970 | 1971-1980 | > 1980 | > 1990 | |
| EU-25 | 184166 | 54 % | 46 % | 15 % | 12 % | 32 % | 20 % | 22 % | 13 % | 87 |
| A | 3 280 | 48% | 52 % | 19 % | 8 % | 27 % | 16 % | 12 % | 18 % | 94 |
| B | 4325 | 75% | 25 % | 15 % | 17 % | 29 % | 15 % | 9 % | 15 % | 86 |
| CY | 239 | na | na | Na | 7 % | 17 % | 21 % | 27 % | - | 145 |
| CZ | 4216 | 44 % | 57 % | 11 % | 15 % | 26 % | 23 % | 16 % | 8 % | 76 |
| DK | 2481 | 61 % | 39 % | 20 % | 17 % | 28 % | 18 % | 10 % | 7 % | 109 |
| EST | 566 | 32 % | 68 % | 9 % | 14 % | 30 % | 22 % | 20 % | 5 % | 60 |
| FIN | 2378 | 42 % | 58 % | 2 % | 9 % | 31 % | 23 % | 20 % | 14 % | 77 |
| F | 24525 | 57 % | 43 % | 20 % | 13 % | 18 % | 26 % | 10 % | 12 % | 90 |
| D | 38944 | 46 % | 54 % | 15 % | 13 % | 47 % | 11 % | 15 % | - | 90 |
| GR | 3674 | 59 % | 41 % | 3 % | 7 % | 32 % | 25 % | 19 % | 14 % | 83 |
| H | 3863 | 66 % | 34 % | 14 % | 13 % | 26 % | 22 % | 18 % | 7 % | 75 |
| IRL | 1382 | 91 % | 9 % | 10 % | 8 % | 16 % | 18 % | 16 % | 32 % | 104 |
| IT | 22004 | 25 % | 75 % | 19 % | 11 % | 41 % | 20 % | 10 % | - | 90 |
| LT | 915 | 29 % | 71 % | 11 % | 14 % | 28 % | 23 % | 21 % | 4 % | 55 |

⁹ <http://ec.europa.eu/environment/ipp/identifying.htm>

| | | | | | | | | | | |
|------------|-------|------|------|------|------|------|------|------|------|-----|
| LIT | 1346 | 39 % | 61 % | 6 % | 23 % | 33 % | 18 % | 14 % | 6 % | 61 |
| LUX | 171 | 71 % | 29 % | 12 % | 15 % | 27 % | 15 % | 12 % | 17 % | 125 |
| MT | 129 | na | na | 15 % | 11 % | 29 % | 17 % | 16 % | 12 % | 106 |
| NL | 6996 | 69 % | 31 % | 7 % | 13 % | 31 % | 19 % | 30 % | - | 98 |
| PL | 13337 | 37 % | 63 % | 10 % | 13 % | 27 % | 18 % | 19 % | 13 % | 68 |
| P | 3651 | 77 % | 23 % | 6 % | 9 % | 23 % | 18 % | 44 % | - | 83 |
| SK | 20272 | 49 % | 52 % | 3 % | 7 % | 35 % | 26 % | 21 % | 7 % | 56 |
| SLO | 685 | 72 % | 28 % | 15 % | 8 % | 28 % | 24 % | 16 % | 9 % | 75 |
| E | 14187 | 53 % | 48 % | 9 % | 4 % | 34 % | 24 % | 14 % | 16 % | 90 |
| S | 4454 | 48 % | 52 % | 12 % | 20 % | 33 % | 17 % | 10 % | 7 % | 92 |
| UK | 24346 | 81 % | 19 % | 21 % | 18 % | 21 % | 22 % | 19 % | - | 87 |

Table 2-12: Characteristics of the EU heated area, residential sector – source (VHK Lot1, 2006)

Germany, UK, Italy, Cyprus, Portugal and the Netherlands suffer from a small problem in the original report. For the six countries with missing figures we split the figure “after 1975” equally before and after 1995. The values obtained have been used in the following.

To cover all countries we generated default values about individual housing, by grouping countries according to their history in ventilation. The result is given in table 2.13.

| Share in individual houses ¹⁰ | % of DV before 1990 | % of ICV before 1990 | % of DV after 1990 | % of DV&HR after 1990 | % of ICV after 1990 | % of ICV&HR after 1990 |
|--|---------------------|----------------------|--------------------|-----------------------|---------------------|------------------------|
| GROUP 1 Northern DK FIN S | 15 % | 15% | | | 10% | 90% |
| GROUP 2 Middle North A IRL SLO UK D | 35 % | 10% | 35 % | 5 % | 10% | 10% |
| GROUP 3 Middle South B F LUX NL | 30 % | 40% | | | 95 % | 5 % |
| GROUP 4 Southern CY GR IT MT P E | 20 % | | 35 % | | 5% | |
| GROUP 5 NMS CZ EST H LT LIT PL SK | 5 % | | 5 % | | 5 % | |

Table 2-13: Default values of technical shares of ventilation system types to model the EU stock of ventilation fans in EU single dwellings (excl. collective)

In both individual and collective ventilation, when a dwelling is treated by decentralised ventilation it means for us 1.5 fan per average dwelling (on average, 0.8 intermittent in the kitchen hood, 0.6 intermittent in a wet room, either wall or window, 0.1 continuous in another wet room). Obviously some dwellings have two fans and others have one. Many dwellings (all percentages not allocated to one technique) have no mechanical ventilation.

In collective dwellings all over Europe we consider that Centralised products treat 5 flats per fan. This last figure (5 flats per fan) takes into account the following: there is more than one exhaust fan per flat

¹⁰ Mostly based on table 2-2, GROUP1 on Finland, GROUP 2 on UK, GROUP 3 on FR, GROUP 4 on IT GROUP 5 on PL but adjusted for consistency

(typically 2 or 3) but they are located at different places. In a five storeys building there may be 10 flats, and 20-30 extracts. However for economic reasons (limiting air ducts to the vertical sections, and grouping of extracts on two sides of a wall) and technical reasons (the maximum air flow of the fan), the designer will decide to have typically 2 or 3 fans, hence the figure of 5 flats per fan.

| Share in collective dwellings | % of DV before 1990 | % of CCV before 1990 | % of DV after 1990 | % of DV&HR after 1990 | % of CCV after 1990 | % of CCV&HR after 1990 |
|---------------------------------|---------------------|----------------------|--------------------|-----------------------|---------------------|------------------------|
| GROUP 1 Northern DK FIN S | | 80% | | | 70% | 30% |
| Other groups | 10 % | 40% | 30 % | | 50% | |

Table 2-14: Default values of technical shares of ventilation system types to model the EU stock of ventilation fans in EU collective dwellings

The default values were only provisional and have been substituted with national survey values in most cases. The work described allowed to generate an estimate of the number of pieces of equipment in use in both individual and collective dwellings, and of the area covered by the collective techniques CCV and CCV&HR in collective buildings (area being a factor that appeared more adequate for energy calculation in that segment).

If we admit the 10 year life time adopted in lot 11 for non residential use, the EU sales for renovation is of the order of magnitude of one tenth of stock figures. One manufacturer indicated a lifetime from 8 to 10 years. Another manufacturer in the residential area indicated a lifetime of 16 years of the products. The only documented evidence comes from the French market and is around 10 years. The value of lot 11 has been kept.

The division of the stock by life duration in years leads us to an estimate of maintenance market figures in the absence of new buildings (substitution of equipment by similar equipment if the market were stable and saturated). Then we have to add the units sold in new construction. We estimated it by computing the flux of new buildings (at the average rate since 1990) from the same VHK source, table 2.12. By doing so we neglect the installation of mechanical ventilation in previously naturally ventilated buildings, one of the reasons for which adjustment to field data is useful.

By adding the two markets (renovation and new buildings) we found the sales figure that we compare to the scarce field indications and to the analysis we derived from Prodcum values.

Adjustment of the purely predictive model at EU level to field data

Whatever the limitations of field data, we then made our best to adapt our model to the field data in the countries having field data. We give now our final estimates obtained by doing so.

Table 2-15: Adjusted technical shares of ventilation system types to model the EU stock of ventilation fans in EU single dwellings (excl. collective)

| Share in individual houses | % of DV before 1990 | % of ICV before 1990 | % of DV after 1990 | % of DV&HR after 1990 | % of ICV after 1990 | % of ICV&HR after 1990 |
|----------------------------|---------------------|----------------------|--------------------|-----------------------|---------------------|------------------------|
| A | 35% | 10% | 35% | 5% | 10% | 5% |
| B | 50% | 40% | | | 95% | 5% |
| CY | 40% | | 35% | | 5% | |
| CZ | 15% | | 5% | | 5% | |
| DK | 15% | 30% | | | 10% | 90% |
| EST | 15% | | 5% | | 5% | |
| FIN | 30% | 30% | | | 10% | 90% |
| F | 10% | 15% | | | 95% | 5% |
| D | 35% | 10% | 35% | 5% | 10% | 5% |
| GR | 40% | | 35% | | 5% | |
| H | 15% | | 5% | | 5% | |
| IRL | 70% | | 70% | | 5% | |
| IT | 40% | | 35% | | 5% | |
| LT | 15% | | 5% | | 5% | |
| LIT | 15% | | 5% | | 5% | |
| LUX | 50% | 40% | | | 95% | 5% |
| MT | 40% | | 35% | | 5% | |
| NL | 30% | 40% | | | 90% | 10% |
| PL | 15% | | 5% | | 5% | |
| P | 40% | | 35% | | 5% | |
| SK | 15% | | 5% | | 5% | |
| SLO | 35% | 10% | 35% | 5% | 10% | 5% |
| E | 40% | | 35% | | 5% | |
| S | 30% | 30% | | | 10% | 90% |
| UK | 20% | | 30% | | 5% | |

Table 2-16: Adjusted values of technical shares of ventilation system types to model the EU stock of ventilation fans in EU collective dwellings

| Share in collective dwellings | % of DV before 1990 | % of CCV before 1990 | % of DV after 1990 | % of DV&HR after 1990 | % of CCV after 1990 | % of CCV&HR after 1990 |
|-------------------------------|---------------------|----------------------|--------------------|-----------------------|---------------------|------------------------|
| A | 20% | | 30% | | 10% | |
| B | 15% | 40% | 30% | | 50% | |
| CY | 15% | 40% | 30% | | 50% | |
| CZ | 15% | 40% | 30% | | 50% | |
| DK | | 80% | | | 70% | 30% |
| EST | 15% | 40% | 30% | | 50% | |
| FIN | | 80% | | | 70% | 30% |
| F | 10% | 35% | | | 100% | |
| D | 20% | | 30% | | 10% | |
| GR | 15% | 40% | 30% | | 50% | |
| H | 15% | 40% | 30% | | 50% | |
| IRL | 80% | 10% | 95% | | 5% | |
| IT | 15% | 40% | 30% | | 50% | |
| LT | 15% | 40% | 30% | | 50% | |
| LIT | 15% | 40% | 30% | | 50% | |
| LUX | 15% | 40% | 30% | | 50% | |
| MT | 15% | 40% | 30% | | 50% | |
| NL | 10% | 40% | 30% | | 50% | |
| PL | 15% | 40% | 30% | | 50% | |
| P | 15% | 40% | 30% | | 50% | |
| SK | 15% | 40% | 30% | | 50% | |

| | | | | | | |
|-----|-----|-----|-----|--|-----|-----|
| SLO | 20% | | 30% | | 10% | |
| E | 15% | 40% | 30% | | 50% | |
| S | | 80% | | | 70% | 30% |
| UK | 80% | 10% | 95% | | 5% | |

This adjustment leads us to our third and final estimate of the stock of products in use:

Table 2-17: Adjusted estimate of the stock of distributed ventilation fans in use in number of units in EU-25 in 2005

| Estim.3 Stock ~1000 | Nb DV in use continuous | Nb DV in use On/off | Nb DV&HR in use Cont. | Total DV stock | Nb hoods prodcom + Est. | Nb fans prodcom + Est | Nb DV prodcom + Est |
|---------------------|-------------------------|---------------------|-----------------------|----------------|-------------------------|-----------------------|---------------------|
| EU-25 | 4527 | 63377 | 84 | 67987 | 47840 | 34223 | 82063 |
| A | 92 | 1292 | 14 | 1398 | 383 | 889 | 1272 |
| B | 157 | 2191 | 0 | 2348 | 647 | 1338 | 1985 |
| CY | 7 | 97 | 0 | 104 | 102 | 49 | 151 |
| CZ | 65 | 914 | 0 | 979 | 802 | 473 | 1275 |
| DK | 21 | 296 | 0 | 317 | 716 | 310 | 1026 |
| EST | 9 | 122 | 0 | 130 | 102 | 41 | 143 |
| FIN | 26 | 361 | 0 | 387 | 326 | 465 | 791 |
| F | 216 | 3021 | 0 | 3237 | 4987 | 4969 | 9956 |
| D | 1063 | 14887 | 67 | 16018 | 8569 | 4268 | 12837 |
| GR | 111 | 1553 | 0 | 1664 | 761 | 898 | 1659 |
| H | 58 | 806 | 0 | 863 | 586 | 498 | 1084 |
| IRL | 99 | 1380 | 0 | 1479 | 383 | 1061 | 1444 |
| IT | 479 | 6700 | 0 | 7179 | 16076 | 1126 | 17202 |
| LT | 14 | 196 | 0 | 210 | 244 | 49 | 293 |
| LIT | 21 | 289 | 0 | 309 | 256 | 106 | 362 |
| LUX | 6 | 83 | 0 | 89 | 45 | 57 | 102 |
| MT | 4 | 52 | 0 | 56 | 16 | 24 | 40 |
| NL | 151 | 2118 | 0 | 2269 | 969 | 2040 | 3009 |
| PL | 210 | 2940 | 0 | 3150 | 590 | 2220 | 2810 |
| P | 125 | 1746 | 0 | 1871 | 859 | 1877 | 2736 |
| SK | 311 | 4357 | 0 | 4669 | 269 | 2162 | 2431 |
| SLO | 21 | 298 | 2 | 321 | 130 | 122 | 252 |
| E | 413 | 5785 | 0 | 6199 | 5451 | 3664 | 9115 |
| S | 60 | 835 | 0 | 895 | 187 | 465 | 652 |
| UK | 790 | 11057 | 0 | 11847 | 4384 | 5051 | 9435 |

Table 2-18: Adjusted estimate of the stock of centralised ventilation fans in use in number of units in EU-25 in 2005

| Estim.3 Stock ~1000 | Nb ICV in use 1 or 2 dwelling | Nb ICV&HR in use 1 or 2 dwell. | Nb CCV in use Coll. Dwell. | Nb CCV&H R in use Coll. Dwell. | Area CCV Coll. dwell. | Area CCV&H R Coll. Dwell. |
|---------------------|-------------------------------|--------------------------------|----------------------------|--------------------------------|-----------------------|---------------------------|
| EU-25 | 10992 | 621 | 6161 | 25 | 2510121 | 11150 |
| A | 157 | 14 | 6 | 0 | 2886 | 0 |
| B | 1565 | 24 | 90 | 0 | 38590 | 0 |
| CY | 1 | 0 | 9 | 0 | 6592 | 0 |
| CZ | 7 | 0 | 196 | 0 | 74516 | 0 |
| DK | 433 | 95 | 153 | 4 | 83636 | 2215 |
| EST | 0 | 0 | 31 | 0 | 9353 | 0 |
| FIN | 272 | 126 | 217 | 12 | 83474 | 4460 |
| F | 3439 | 84 | 903 | 0 | 406222 | 0 |
| D | 1791 | 67 | 32 | 0 | 14195 | 0 |
| GR | 15 | 0 | 125 | 0 | 51761 | 0 |
| H | 9 | 0 | 107 | 0 | 40092 | 0 |
| IRL | 20 | 0 | 2 | 0 | 1087 | 0 |
| IT | 14 | 0 | 1337 | 0 | 601534 | 0 |

| | | | | | | |
|------------|------|-----|-----|----|--------|------|
| LT | 1 | 0 | 52 | 0 | 14435 | 0 |
| LIT | 2 | 0 | 67 | 0 | 20334 | 0 |
| LUX | 60 | 1 | 4 | 0 | 2585 | 0 |
| MT | 0 | 0 | 5 | 0 | 2591 | 0 |
| NL | 2293 | 72 | 180 | 0 | 88203 | 0 |
| PL | 32 | 0 | 694 | 0 | 235970 | 0 |
| P | 31 | 0 | 71 | 0 | 29412 | 0 |
| SK | 35 | 0 | 858 | 0 | 240261 | 0 |
| SLO | 49 | 2 | 0 | 0 | 129 | 0 |
| E | 60 | 0 | 567 | 0 | 254957 | 0 |
| S | 611 | 135 | 367 | 10 | 168972 | 4475 |
| UK | 94 | 0 | 88 | 0 | 38332 | 0 |

We can make the following analysis of discrepancies between modeling, prodcom and national figures:

The total stock estimates obtained from this model and from our treatment of the Prodcom data have the same order of magnitude for DV.

In the case of France the stock of 3.2 million ICV and 3.2 million DV compare quite well with the 4.8 mechanically ventilated dwellings since there are various DV in one dwelling.

The model gives a stock of 11.9 million DV in the UK, while a total of 14.5 million is reported in the census (we assumed hoods were considered as DV in the census).

If we accept this stock model, the market estimation becomes the following:

Table 2-19: Adjusted estimate of sales data

| Market Estim.3 ~1000 | Estimate Market DV | Of which Hoods | Of which Fans | Nb hoods from Prodcom (1/2) | Nb fans from Prodcom (T 2,3) | Estimate Market ICV | Estimate Market ICV &HR | Estimate market CCV | Estimate market CCV&H R |
|----------------------|--------------------|----------------|---------------|-----------------------------|------------------------------|---------------------|-------------------------|---------------------|-------------------------|
| EU-25 | 7294 | 3883 | 3411 | 5876 | 4194 | 1316 | 104 | 673 | 4 |
| A | 160 | 84 | 76 | 47 | 109 | 18 | 2 | 1 | 0 |
| B | 240 | 128 | 112 | 80 | 164 | 187 | 4 | 10 | 0 |
| CY | 11 | 6 | 5 | 13 | 6 | 0 | 0 | 1 | 0 |
| CZ | 104 | 56 | 49 | 99 | 58 | 1 | 0 | 21 | 0 |
| DK | 32 | 17 | 15 | 88 | 38 | 44 | 16 | 16 | 1 |
| EST | 14 | 7 | 6 | 13 | 5 | 0 | 0 | 3 | 0 |
| FIN | 39 | 21 | 18 | 40 | 57 | 28 | 21 | 23 | 2 |
| F | 324 | 173 | 151 | 613 | 609 | 450 | 14 | 107 | 0 |
| D | 1701 | 901 | 800 | 1053 | 523 | 188 | 11 | 5 | 0 |
| GR | 183 | 98 | 86 | 94 | 110 | 3 | 0 | 14 | 0 |
| H | 90 | 48 | 42 | 72 | 61 | 1 | 0 | 11 | 0 |
| IRL | 180 | 96 | 84 | 47 | 130 | 3 | 0 | 0 | 0 |
| IT | 752 | 401 | 351 | 1975 | 138 | 2 | 0 | 139 | 0 |
| LT | 22 | 12 | 10 | 30 | 6 | 0 | 0 | 5 | 0 |
| LIT | 33 | 17 | 15 | 32 | 13 | 0 | 0 | 7 | 0 |
| LUX | 9 | 5 | 4 | 6 | 7 | 7 | 0 | 0 | 0 |
| MT | 6 | 3 | 3 | 2 | 3 | 0 | 0 | 1 | 0 |
| NL | 237 | 126 | 110 | 119 | 250 | 273 | 12 | 20 | 0 |
| PL | 351 | 187 | 164 | 73 | 272 | 5 | 0 | 77 | 0 |
| P | 214 | 114 | 100 | 106 | 230 | 5 | 0 | 8 | 0 |
| SK | 492 | 263 | 230 | 33 | 265 | 6 | 0 | 91 | 0 |
| SLO | 34 | 18 | 16 | 16 | 15 | 5 | 0 | 0 | 0 |
| E | 695 | 370 | 324 | 670 | 449 | 10 | 0 | 64 | 0 |
| S | 89 | 48 | 42 | 23 | 57 | 62 | 22 | 38 | 2 |
| UK | 1283 | 684 | 599 | 539 | 619 | 16 | 0 | 9 | 0 |

We can make the following analysis of discrepancies between modeling and prodcom derived figures, as well as national figures :

The modeling of the German market is confirmed by the prodcom figures ; our results are far from the TZWL report which should correspond to something different from the National market.

Our estimate of the Benelux market matches very well with the existing field data.

In Denmark, the flux of new buildings as reported by DTI is in agreement with the VHK figures for new construction in lot1. The market is larger, due to replacement.

The total Scandinavian market of 650 000 units seems to be an overestimation.

Our model respects the sharing of techniques in new construction in the Netherlands.

The French predicted market of 464 000 ICV compares reasonably with the sales statistics of 570 000.

For DV the figures are 324000 and 234 000 respectively.

In the UK the 0.6 million hoods sold yearly according to the model compare with the BSRIA indication of 550 000 hoods, a value which is well supported by the Prodcum statistics.

What follows will be based on modelling figures, not Prodcum or national figures, because we want to play on all parameters in predicting the future markets.

2.3 Market trends

The central question is: which building regulations (e.g. developed under the Performance of Buildings Directive) are leading to forced ventilation as a practical obligation in residences? Which base cases have been taken for energy consumption calculation (with or without some features of the equipment)? This information will decide on the future market trends: either the stable evolution as before or a quick market change in the direction of the centralised extractor. This uncertainty is not legal (since EPBD is enforced) but largely practical: thermal regulations for buildings generally open various ways of compliance; forced ventilation with a certain quality may be part of the less costly package of solutions to comply with the codes in one country and not in another country. Other uncertainties are related to the part of EPBD demanding energy efficiency improvements in case of building retrofit and the demand of the end user for more comfort in air quality.

Impact of the EPBD is high in new buildings. The market seems to move from local intermittent to continuous centralised ventilation, and then towards the introduction of more sophisticated systems. In many countries moving from natural ventilation to controlled (mechanical) ventilation is among the most cost effective ways to fit into the new range of energy consumption allowed. The market of ICV will consequently explode. In countries with mostly natural ventilation the trend will be towards DV (or directly ICV?).

Some stakeholders have reported that this step into centralised mechanical ventilation is being done in the frame of EPBD especially in the following countries: Czech Republic, Italy, Poland, Spain, United Kingdom.

Double flow systems (balanced ventilation) are still infrequent but expanding in new buildings. **In the Netherlands** the very strict building codes pushed them up to 30 % of the market recently (ENPER 2006) and we can consider they will have a higher value in the coming years, like 50 %. This percentage already reaches 6 % **in Germany** (TZWL, 2007). TZWL also proposed a scenario of future sales of double flow systems with heat recovery. It has three variants, high, medium and low. Remember there is decentralised and centralised equipment in the figures.

The EPBD section about large retrofits may also have some effect, difficult to indicate now. We have limited the effect of improvements to the introduction of a better equipment of the same type in a maintenance operation, and not considered introduction of a certain type of equipment in a building designed for another ventilation.

Figure 2-4: Market previsions of the growth of residential mechanical ventilation in Germany (TZML, 2007)

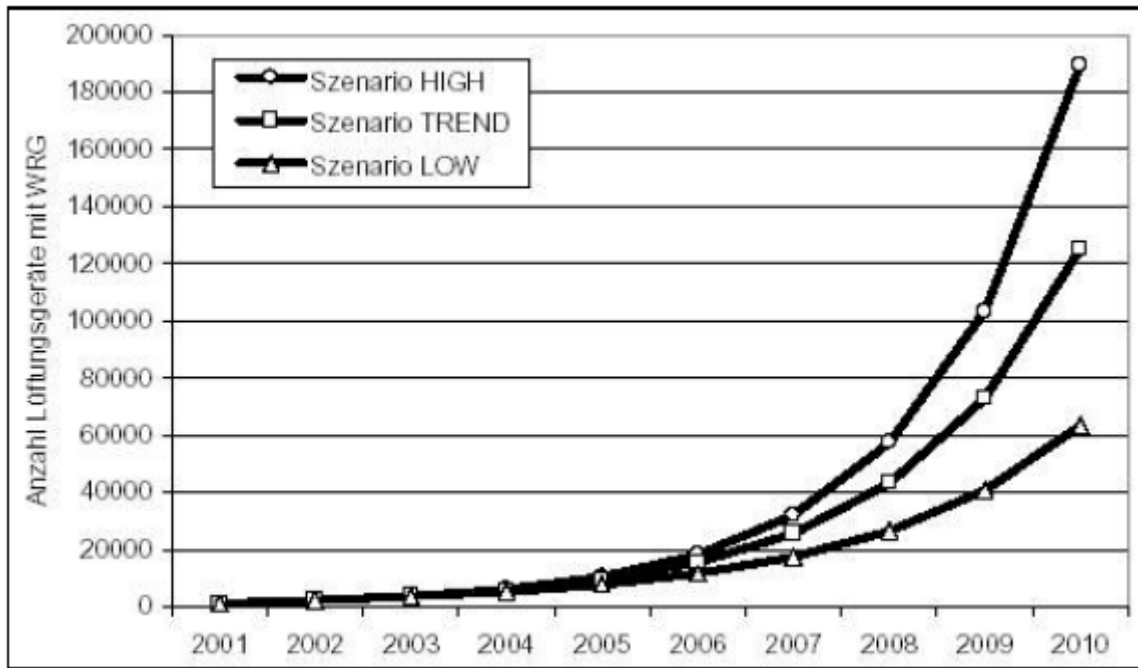

A few percent of the market will also be gained in the remaining countries with high standards on energy in buildings. From our perspective, this category of products a priori requests more electricity than simple extraction because of the two fans and of the added heat exchanger in the flow air stream.

In some countries, like **Finland**, heat recovery efficiency is an integral part of the norms. Some stakeholders from Finland stressed that 90 % of the true matter (the choices made for the ventilation) is ignored in an EuP study whilst max 10 % of the true energy usage (the electricity part, as opposed to the heating demand generated by ventilation) gets 100 % of the focus. However, we maintain this approach of considering only the product and not the system, which includes heat recovery or not, depending on the country, a factor that we will not change here, and that results from national decisions taken at the time of EPBD.

In Finland and other Nordic countries, the stakeholders indicate that most new buildings are equipped with mechanical supply+exhaust ventilation (e.g one-family houses more than 90 % and commercial buildings practically 100 %), and practically 100 % of these with heat recovery. (If not, this must be compensated by e.g. additional thermal insulation, or windows with U-value far below 1).

Logically some MS already thought about the electricity consumption added. There is a label with a certain market significance **in Germany**: “Passivhaus geeignete Komponente” which, among others can be applied to the central unit of the balanced double flow unit. It requires a heat exchanger with 75 % effectiveness, an SFP lower than 0.45 W/(m³/h) which seems not as difficult to reach as one could expect, but includes the effect of the heat exchanger head losses, and leakage rates of air flow rate lower than 3 %.

There is a kind of label leading to “white certificates” allowance **in France** for the central unit of the balanced double flow unit (ATEE, 2006). It requires a heat exchanger with 85 % effectiveness, an SFP lower than 0.30 W/(m³/h) for each of the flows, and demands duct insulation higher than 1.2 m².K/W. There is a limit of 80 W on total electricity consumption in the case of individual houses. There is check of air permeability of the building. The revision of building codes may lead to a penetration of heat recovery following the Netherlands with some delay.

We summarise presently the trends by a marginal penetration rate (in the new dwellings after 2005). First for individual houses:

Table 2-20: Projections to 2025, penetration of mechanical ventilation in new dwellings – individual houses

| Share in individual houses | % of DV before 1990 | % of ICV before 1990 | % of DV 1990-2005 | % of DV&H R 1990-2005 | % of ICV 1990-2005 | % of ICV&H R 1990-2005 | % of DV 2005-2025 | % of DV&H R 2005-2025 | % of ICV 2005-2025 | % of ICV&H R 2005-2025 |
|----------------------------|---------------------|----------------------|-------------------|-----------------------|--------------------|------------------------|-------------------|-----------------------|--------------------|------------------------|
| A | 35% | 10% | 35% | 5% | 10% | 5% | 35% | 15% | 25% | 25% |
| B | 50% | 40% | | | 95% | 5% | | | 75% | 25% |
| CY | 40% | | 35% | | 5% | | 75% | | 5% | |
| CZ | 15% | | 5% | | 5% | | 25% | | 75% | |
| DK | 15% | 30% | | | 10% | 90% | | | 10% | 90% |
| EST | 15% | | 5% | | 5% | | 25% | | 75% | |
| FIN | 30% | 30% | | | 10% | 90% | | | 0% | 100% |
| F | 10% | 15% | | | 95% | 5% | | | 75% | 25% |
| D | 35% | 10% | 35% | 5% | 10% | 5% | 75% | 15% | 45% | 25% |
| GR | 40% | | 35% | | 5% | | 75% | | 5% | |
| H | 15% | | 5% | | 5% | | 25% | | 75% | |
| IRL | 70% | | 70% | | 5% | | 30% | | 40% | |
| IT | 40% | | 35% | | 5% | | 75% | | 5% | |
| LT | 15% | | 5% | | 5% | | 25% | | 75% | |
| LIT | 15% | | 5% | | 5% | | 25% | | 75% | |
| LUX | 50% | 40% | | | 95% | 5% | | | 75% | 25% |
| MT | 40% | | 35% | | 5% | | 75% | | 5% | |
| NL | 30% | 40% | | | 90% | 10% | | | 75% | 25% |
| PL | 15% | | 5% | | 5% | | 25% | | 75% | |
| P | 40% | | 35% | | 5% | | 75% | | 5% | |
| SK | 15% | | 5% | | 5% | | 25% | | 5% | |
| SLO | 35% | 10% | 35% | 5% | 10% | 5% | 35% | 15% | 25% | 25% |
| E | 40% | | 35% | | 5% | | 75% | | 5% | |
| S | 30% | 30% | | | 10% | 90% | | | 0% | 100% |
| UK | 20% | | 30% | | 5% | | 30% | | 40% | |

Now for collective housing:

Table 2-21: Projections to 2025, penetration of mechanical ventilation in new dwellings – collective housing

| Share in collective dwellings | % of DV before 1990 | % of CCV before 1990 | % of DV 1990 2005 | % of DV & HR 1990 2005 | % of CCV 1990 2005 | % of CCV & HR 1990 2005 | % of DV 2005 2025 | % of DV & HR 2005 2025 | % of CCV 2005 2025 | % of CCV & HR 2005 2025 |
|-------------------------------|---------------------|----------------------|-------------------|------------------------|--------------------|-------------------------|-------------------|------------------------|--------------------|-------------------------|
| A | 20% | | 30% | | 10% | | 75% | 10% | 10% | 5% |
| B | 15% | 40% | 30% | | 50% | | 45% | | 50% | 5% |
| CY | 15% | 40% | 30% | | 50% | | 30% | | 50% | |
| CZ | 15% | 40% | 30% | | 50% | | 50% | | 50% | |
| DK | | 80% | | | 70% | 30% | | | 50% | 50% |
| EST | 15% | 40% | 30% | | 50% | | 50% | | 50% | |
| FIN | | 80% | | | 70% | 30% | | | 50% | 50% |
| F | 10% | 35% | | | 100% | | | | 75% | 25% |
| D | 20% | | 30% | | 10% | | 65% | | 10% | 25% |
| GR | 15% | 40% | 30% | | 50% | | 30% | | 50% | |
| H | 15% | 40% | 30% | | 50% | | 50% | | 50% | |
| IRL | 80% | 10% | 95% | | 5% | | 95% | | 5% | |
| IT | 15% | 40% | 30% | | 50% | | 30% | | 50% | |
| LT | 15% | 40% | 30% | | 50% | | 50% | | 50% | |
| LIT | 15% | 40% | 30% | | 50% | | 50% | | 50% | |
| LUX | 15% | 40% | 30% | | 50% | | 25% | | 50% | 25% |
| MT | 15% | 40% | 30% | | 50% | | 30% | | 50% | |
| NL | 10% | 40% | 30% | | 50% | | 25% | | 50% | 25% |
| PL | 15% | 40% | 30% | | 50% | | 50% | | 50% | |
| P | 15% | 40% | 30% | | 50% | | 30% | | 50% | |
| SK | 15% | 40% | 30% | | 50% | | 50% | | 50% | |
| SLO | 20% | | 30% | | 10% | | 65% | | 10% | 25% |
| E | 15% | 40% | 30% | | 50% | | 30% | | 50% | |
| S | | 80% | | | 70% | 30% | | | 50% | 50% |
| UK | 80% | 10% | 95% | | 5% | | 90% | | 5% | 5% |

Obviously in existing buildings products will be replaced by identical products, in the absence of a clear application of the EPBD article on retrofits.

Starting from the residential area and repartition from table 2-12, we can estimate the stock from 2005 to 2025. The growth rate of the total residential building stock is of 0,9 % yearly (VHK Lot1, 2006). MS yearly growth rates give the new built area yearly and thus the increase of total built area. Given the low level of demolition/removed surfaces, this removal rate is supposed null. Combining tables 2.20 and 2.21 with the total built area gives the stock evolution by country. Stock figures for equipment can be deduced.

The corresponding stock estimates are reported for EU25.

Table 2-22: Projections to 2025, stock estimate EU 25

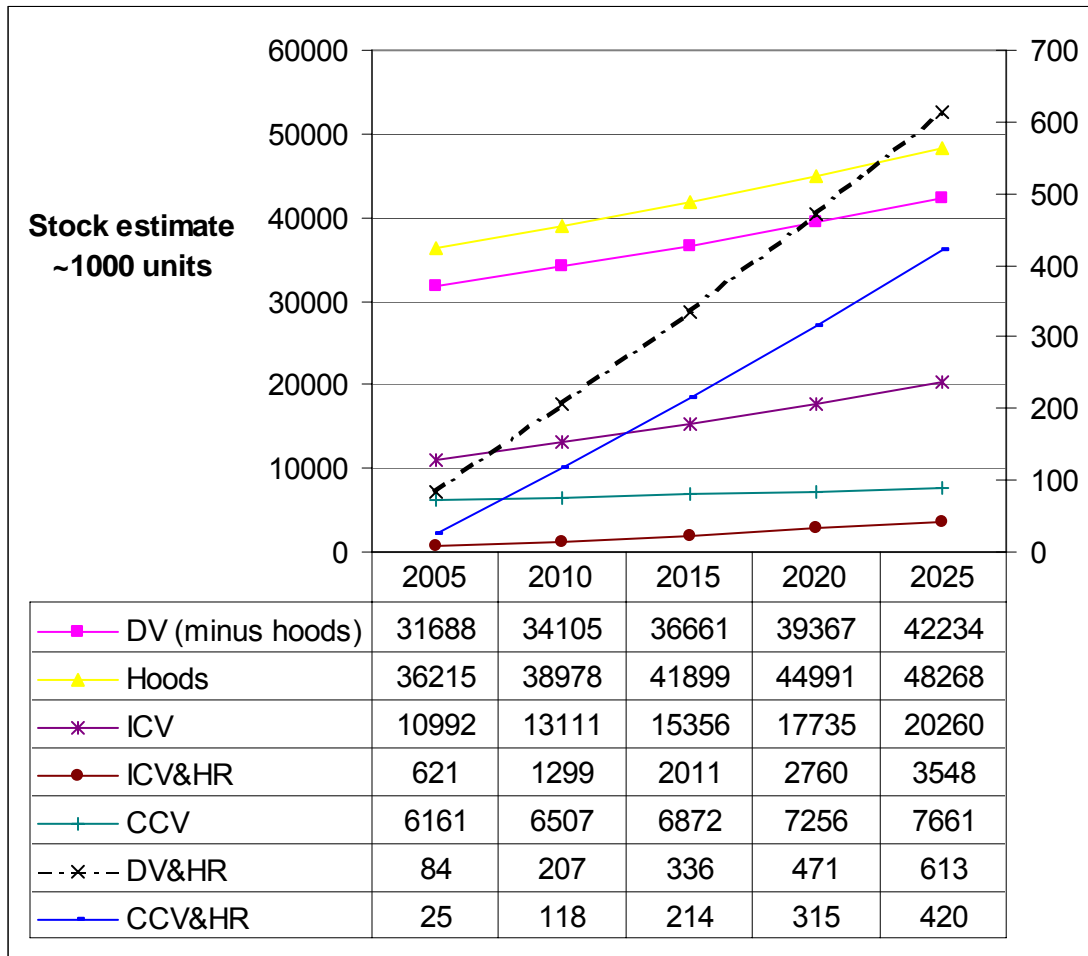

Figure 2-5: Projections to 2025, market estimate EU 25

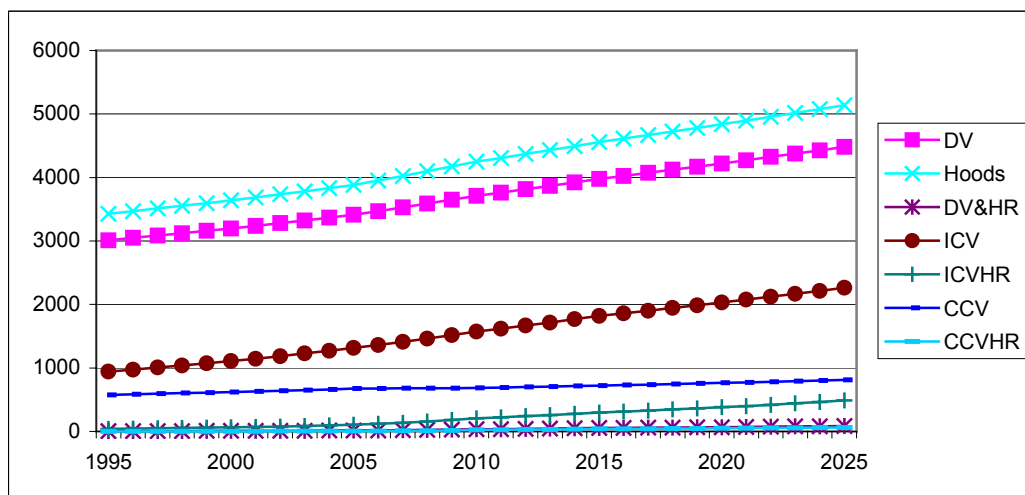
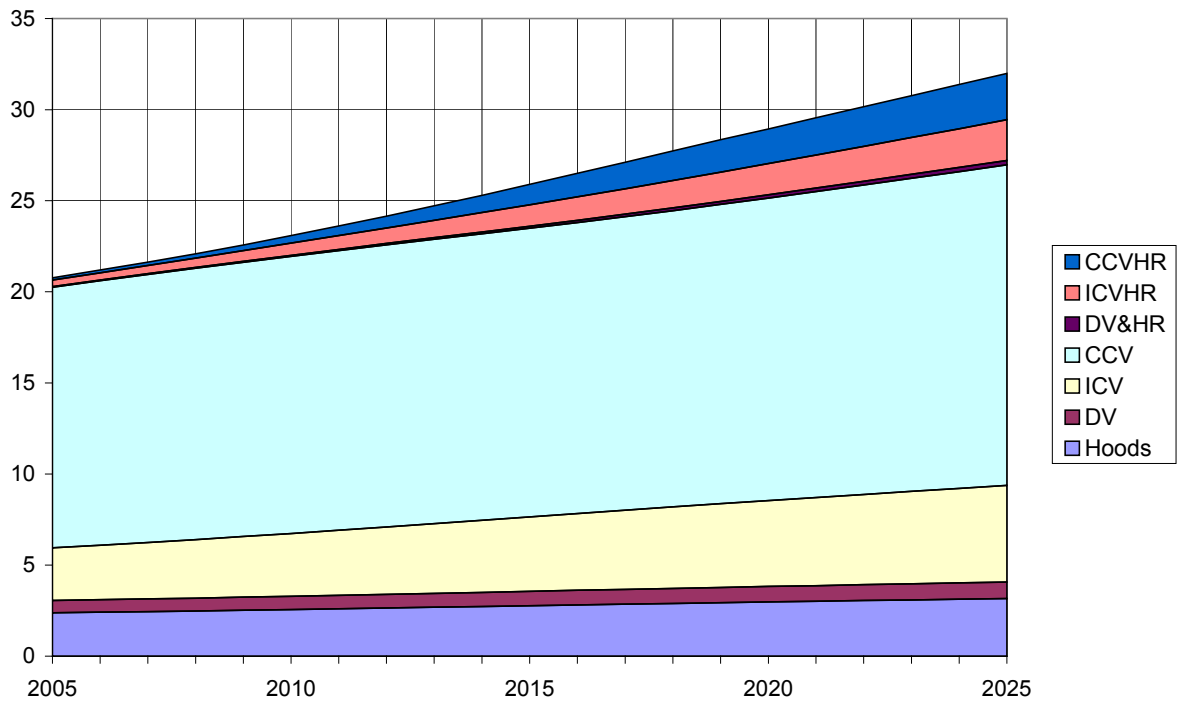
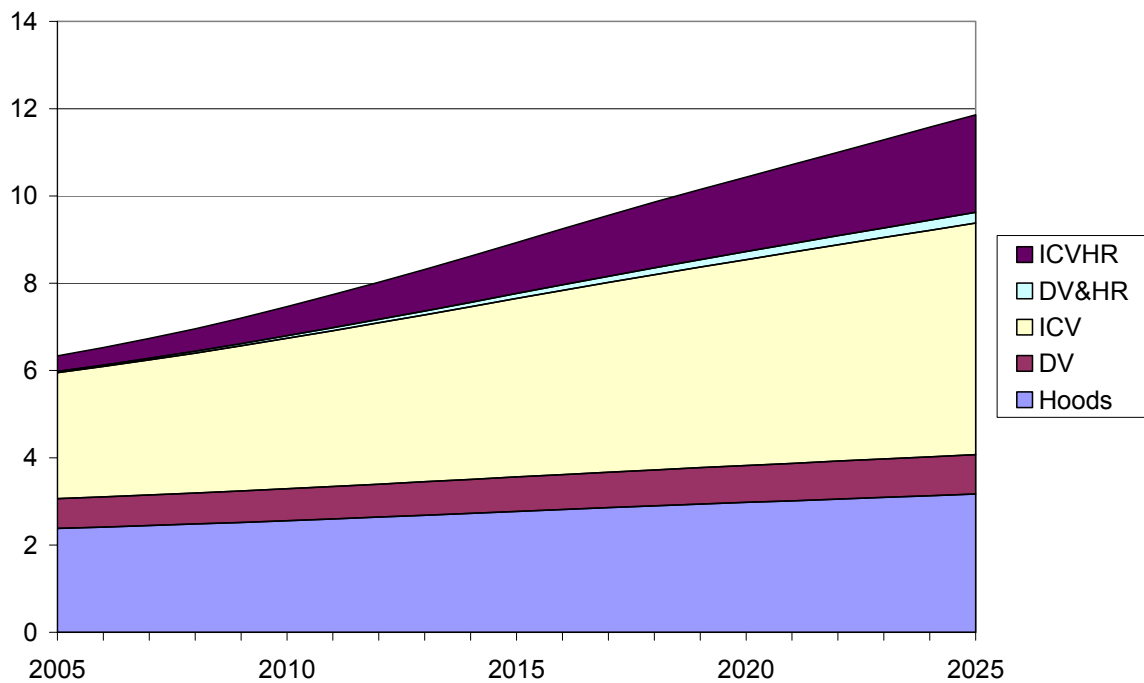

Figure 2-6: Projections to 2025, consumption estimate EU 25 for all forms of residential ventilation (in TWh)



The expansion of products with heat recovery is clear but still limited because it grows mostly in new construction.

Figure 2-7: Projections to 2025, consumption estimate EU 25 for residential ventilation products in the scope of this lot (in TWh)



We see that the products in our scope here are the fastest growing segment, even if collective residential ventilation covered by lot 11 is the largest consuming segment.

Let us keep in mind the essential consumption figures, in table

Table 2-3: Projections to 2025, consumption estimates

| Consumption in TWh | Hoods | Other DV | ICV | DV&HR | ICV&HR | total |
|---------------------------|--------------|-----------------|------------|------------------|-------------------|--------------|
| 2005 | 2,38 | 0,68 | 2,89 | 0,03 | 0,36 | 6,34 |
| 2010 | 2,56 | 0,73 | 3,45 | 0,06 | 0,67 | 7,46 |
| 2015 | 2,77 | 0,79 | 4,09 | 0,12 | 1,17 | 8,94 |
| 2020 | 2,98 | 0,85 | 4,72 | 0,18 | 1,71 | 10,43 |
| 2025 | 3,17 | 0,90 | 5,31 | 0,24 | 2,24 | 11,86 |

Due to their higher unitary electricity consumption, the growth of products with heat recovery seems even higher under this form.

2.4 Consumer expenditure base data

According to the MEEuP methodology, task 2.4 should contain:

For each of the categories defined in subtask 1.1:

Average consumer prices, incl. VAT, in Euro.

Determination of applicable rates for running costs and disposal, per EU Member State, specifically

- Electricity rates (€/ kWh);*
- Consumer prices of other consumables filters*
- Repair, cleaning and Maintenance costs (€/product life);*
- Installation costs (for installed appliances only);*
- Disposal tariffs/ taxes (€/product);*

The typical cost of an individual centralised system ICV in a competitive market is 250 Euros + 250 Euros installation if well planned. An over cost of 200 Euros at least is found when it is a replacement, as compared with a new installation in a new building. The centralised ventilation product with heat recovery ICV&HR will cost at least 2000 Euros.

Collective Centralised products, CCV cost by themselves from 300 to 1000 Euros according to building size but most of the cost comes from the rest of the ventilation system.

The decentralised product not hood has a low price, under 100 Euros, typically 30 Euros which raises over 700 Euros in case of double flow with heat recovery. Depending on the works to be done installation can be anywhere up from 0 to 100 Euros.

Hoods average could be 400 Euros, of which 200 euros of technical parts and the rest in decorative parts.

Electricity average price is 0.158 euro / kWh and discount rate equals 2 % (more information can be found in the air conditioner study). Maintenance is usually a full change of equipment.

Task 2 summary

An estimate of the stock of equipment in use has been made and adjusted to existing field data. It shows a large penetration of DV (68 million units, including kitchen hoods connected to the outside) and CV (18 million units) but still the domination of natural ventilation.

The decentralised ventilation fans, including hoods, (our estimate: 7.3 million units/year, of which more than 4 million hoods in ventilation mode) and the individual extractors serving various rooms in one house (our estimate: 1.4 million units/year) are clearly above the EuP threshold of 200 000 products per year. The ventilation device with the largest penetration in Europe is the range hood. Hoods used as a ventilation mean and hoods used in recycling mode are the same product: the decision on how to use the hood is made by the final user and the energy and resources use is the same in both situations, as well as the improvement possibilities. A default sharing coefficient has been selected and validated.

Heat recovery products (80 000 DV and 20 000 CV) are still marginal. This is a second reason for them not to be in the scope of requirements in chapter 8.

The products for collective ventilation are estimated at 700 000 units per year but this estimation suffers of the absence of clear field data. However we can consider that the products used to ventilate the office buildings which are not air conditioned are the same as the products used to ventilate the residential buildings considered here. They are treated in lot 11. However attention is drawn to the specifications of the residential sector in terms of adaptation to demand. Our solutions in chapters 4 and 6 could be useful to lot 11.

3 CONSUMER BEHAVIOUR AND LOCAL INFRASTRUCTURE

3.1 Real Life Efficiency

Consumer behaviour is often characterised by lack of awareness about the ventilation equipment and about air quality: the equipment is usually continuously in use and the effects of its operation are not related to one of the five senses. This lack of functional feedback is a barrier to eco-design measures, or even to the simplest maintenance and design operations: the equipment and its status are ignored by the end user, its electricity consumption is some kind of non perceived stand by. That is why ventilation is a subject for sanitary regulation in all Member States. The relevant use parameters that influence the environmental impact during product-life are very different from the Standard test conditions as described in Subtask 1.2 since the product is one single package designed to suit many practical situations (number of rooms, types of opening control, etc.) and that may be inefficient in a number of them.

An explanation for the user to understand the important factors of system design having an influence on product behaviour and related with the end user choices:

- 1- Ventilation increases the demand for heating and cooling (thermal demand) but is needed for IAQ (Internal Air Quality) reasons.
- 2- Natural ventilation can be designed as a system in order to give a flow rate as stable as possible.
- 3- Natural ventilation can be designed room by room or taking the dwelling as a full system (inlets in some rooms, outlets in some other rooms, called the “wet” rooms)
- 4- Artificial ventilation avoids fluctuations of air changes (ACH = air change per hour) existing with natural ventilation: both the high values generating high loads (and discomfort) and the small values not respecting the proper IAQ. This is obtained by a proper system design (exhausts, ducts, extraction fan).
- 5- This mechanical system design can be made room by room (decentralised artificial ventilation, mostly window, wall and range hood in kitchens) or for the entire dwelling as a single system (extraction fan).
- 6- We are concentrating here on the ventilation equipment of local and central artificial ventilation, the one using electricity, not the system design which belongs to the field of national regulations.
- 7- Efficiency will be judged at product level but this is only part of ventilation system efficiency, a **trade-off between electricity consumed, thermal energy saved and internal air quality obtained.**
- 8- However some extraction products adapt better with the other components and/or may adapt better to the various conditions met on the field, by using less electricity for the same result.

The decisions to be taken are not even explained to the end user. In most cases, the home builder or installer decides on the initial choices, like natural vs mechanical ventilation, as a consequence of national habits and regulations.

At the end, the installer selects an equipment according to its commercial agreements, substitution is done to the identical. The coherence may be given by the manufacturers because of the frequently sold “packages” or “kits” with corresponding equipment. In the other cases, it may happen that the exhausts, inlets and fans are non consistent.

Speaking of retrofit, the air conditioner called “single duct” can also be considered as a ventilation system. It has always a pure ventilation option, where it only puts the room in under pressure, expels some air, but generates a flux into the room coming from another room or from outside. When it’s used as an air conditioner it has the two functions at the same time: ventilation and cooling. The interaction may be productive if the air incoming is cool (free cooling from underground or from outside) or negative (if the air from outside brings heat into the room).

As will be described technically in the following, the pressure of EPBD based and MS regulations towards the decrease of thermal energy use in heating the air lead to enormous variations in air flow, i.e. in load, to take into account actual occupation at each instant.

The impact of mechanical ventilation is twofold at system level. A study by Ademe/ATEE (ATEE, 2006) indicates the magnitude of yearly thermal energy gains obtained by introducing a simple mechanical ventilation with “self adjustment by special extracts” instead of “natural ventilation” (Passive stack ventilation from the 70s in France): from 2894 kWh to 1154 kWh in individual houses (1740 kWh savings), from 1838 kWh to 733 kWh in flats (1105 kWh savings), in both cases 60% of initial consumption expressed in “useful energy”. The associated yearly electricity consumption, assuming an old 50 W extraction unit is about 437 kWh. This means a significant final energy saving, but not so much when translated in “primary energy” with the factor 2.5. For instance with an efficient boiler in a flat the saving is 1381 kWh primary and the additional consumption is 1092 kWh primary. The more efficient the extraction is, the more savings can be attributed to mechanical ventilation, either in final or primary energy.

Noise

Noise impact of ventilation is significant: noise coming from the fan through the ducts, from outside through air inlets, noise travelling between rooms or apartments through ducts, etc. Passive dampers are routinely used, and do not solve completely the problem. Noise impact depends more on the capacities of the installer to use good ducts, dampers, intermediate sound trap than on the acoustic source itself.

Available end user control

Some ventilation devices are controlled by the light switch (in restrooms for instance) or by timer (hoods). Their real use time is relatively small because of the direct link with another energy service or because of customer awareness. It is namely the case for decentralised systems or systems having a constant flow and intermittent use.

Most ventilation devices are integrated in the building. They operate continuously but adapt to conditions. Some other offer various speeds either as a free choice or associated with the use of the kitchen hood. The control of two, three or four speeds may be done with a manual command, and sometimes a timer (the fan comes back to lower speed after one hour). Some only adapt to the pressure variations in the incoming ducts.

The system is the following (in the case of under pressure).

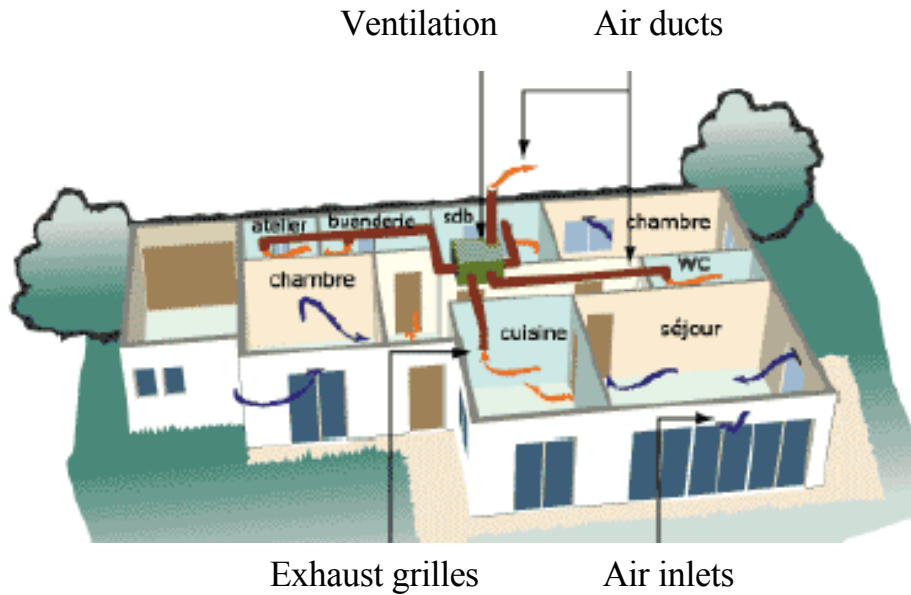

Figure 3-1: Centralized mechanical exhaust and natural supply ventilation system, from (ADEME, 2007)

The envelope openings (cracks or trickle inlets) by which infiltration takes place are an essential part of the ventilation system. Some windows include already the calibrated trickle inlets. A certain pressure drop is generated. In some cases the air inlets are self adjusting (keeping air flow constant despite of pressure or even humidity sensitive). Part of infiltrated air is used in transverse ventilation due to pressure differences on the outside of the building shell. Part is extracted by the fan.

The influence of ducts and extracts on the fan in an ICV

Various types of extract grilles or ATDs can be used. The self adjusting extract grilles realise a constant flow rate predetermined by the manufacturer and the installer, typically for one room between 15 (small wet rooms) and 150 m³/h (the real minimum for a kitchen hood). They can be opposed to the less efficient constant non self regulating grilles. These last ones may however give the occupant the possibility to open and close the grilles according to his (her) present occupation, namely in kitchens and rest rooms. Sometimes both the self adjustment and the manual adjustment possibility are realised. The self adjusting extract grilles succeed in maintaining constant flow typically between 50 and 200 Pascal. The humidity sensitive extracts may operate between 100 and 160 Pascal.

For centralised systems, ducts are typically 80 mm wide for wet rooms, sometimes 125 mm wide for kitchens, 125 or 150 mm wide for rejection to the outside, and a few meters long.



Figure 3-2: Example of ducts, Courtesy Atlantic- (CFP, 2006)

A centralised system should be balanced. This means design or selection of adequate components but also a balancing work on the field.

The ventilation package interferes with the ducts and mostly with the exhausts through pressure changes. There is no control using electronic transmission of information to our knowledge: only the traveling signal given by pressure is used, for obvious cost reasons. The extracts have a constant opening (most of them) or provide a constant flow (self adjustment of head losses) or for a few recent products sense IAQ (usually through humidity content) and open gradually in case of occupation of the room. They all need a certain depression, which is provided by the ventilation package. The more sophisticated products require a higher depression to operate.

The ducts are made of plastic or metal. Taking into account the pressure drop in the extracts and in the ducts (of variable length) one could compute an ideal extraction fan. Practically there is only a few sizes and the fan is always oversized, which is a good thing if we take into account what can happen to ducts and exhausts (breakage, dust, etc.). The quality of design and installation is poor compared with what one could expect. Installation should in principle include balancing and tuning operations in terms of a few Pascals. Papers at AIVC 2005 congress tell more about the ducting problems.

The solutions for demand control in residences are different from the ones used in non residential buildings, where workers can be followed by infrared detectors to determine the number of people in a room, or where CO₂ is a good indicator of activity (which is not the case in a kitchen for instance). Only water content of the air is used.

The work of the designer and installer in interaction with the manufacturer

Five ventilation products at least are assembled to realise the ventilation function and they are assembled at the last minute, on site: (following the flow) we find the trickle inlets for fresh air entrance into the room, the extracts for partial air extraction (part of the air flowing outside directly), ducts, the fan, ducts again, air rejection device. Pressure levels command the flow, and outside pressure varies and is different on every wall, so that the flow varies. The pressure differences we are speaking about are tens of Pascal, less than 1/1000 of atmospheric pressure. This explains the problems found in “balancing” systems (obtaining the flow where we want it and as high as we want it).

Many designers and installers have little time to devote to ventilation, an issue that we already characterized as poorly valorised by the end user. Fortunately manufacturers sell often compatible products as a package: the ventilation product (using electricity) and the other products (passive products). The various components are designed to operate in a consistent way.

More complex even is the double balanced system.

In case of centralized ventilation the circulation through open doors and under closed doors is part of the pressure balance, and should be included in the system. There are regulations about internal doors related with ventilation: they oblige to leave a certain space for air circulation between rooms. This aspect is often forgotten by installers.

The sensitivity of ventilation equipment to the way it is installed and maintained is huge, far more than other air moving equipment, like air conditioners, which display a real sensitivity but limited by the awareness of the end user about the effects. The exhausts by which air is extracted may be full of dust, but this is little visible. The air ducts are often broken but they circulate in attics or plenums. The key element that we are considering here, the extractor, is hidden in some technical box in the wet rooms, in the attic, or on the roof. By definition, the air conveyed in the system is wet, dirty, and a good living media for many species from microbial to insects.

The degrees of freedom in the order are:

- the choice of the product;
- the installation of switches or speed selectors for the user ;
- the choice and installation of products at several speeds, the flows being chosen by the installer;
- the choice of a product taking account of the presence (in residential sector: H2O content or manual action)
- the quality and checking of pressure balance.

Mechanical ventilation control possibilities given at part load

There are various ways of control for mechanical ventilation:

- Constant air flow all year long. These CONTINUOUS extractors operate all the year (8760 hours/year) with nominal electricity consumption.
- Intermittent operation at nominal conditions commanded by a switch or a timer acting ON/OFF.
- User controlled or time programmable MULTI SPEED ventilation, typically with two or three air flow values to adjust the flow rate to the occupancy of the building: these extractors operate all the year (8760 hours/year), for instance about 80% at part load and 20% at full load (it depends on the periods of occupancy of the dwellings).
- As one of the ventilation priorities is to remove humidity from the dwelling, ventilation can be controlled according to humidity inside the dwelling. Using humidity sensitive air inlets or extracts, the system can be controlled to achieve a set humidity ratio inside the dwelling.
- Another approach to cope with variable demand is VARIABLE FAN SPEED, typically set to maintain a constant pressure at some point of extract circuit, typically fan entrance.
- Some centralized ventilation systems maintain a given entering airflow whatever the exterior conditions are (wind speed for example) thanks to self-adjustable air admissions, that may also be humidity sensitive.

A timer or clock may be demanded for programming. This control box that is usually separated from the main heating control is underused, poorly understood in daily life.

If we try to explain **very roughly** the evolution taken by building codes by the necessity to make a **trade-off between electricity consumed, thermal energy saved and internal air quality obtained**, we can say

- some countries (like the UK) opted for decentralization, as a way to put the decision at the lowest possible level, which may seem a good point for the three aspects, but not always comfortable and healthy

- some others (Scandinavian, e.g.) are leaving the choice to each end user of a centralized system to open or not an extract which can then have a low pressure drop, but this cannot always guarantee air quality
- others (France f.i.) introduced automatic control of extracts which costs something in electricity because of the pressure drop generated
- some countries (Germany seems the case) are insisting on the total air flow, not on the room by room balancing, a factor of good air quality
- the trend towards direct control of many rotation speeds of the fan (visible in German products) may get importance or not.

We could go further:

- Overventilation to take advantage of night time cool
- Mechanical ventilation could also be partly controlled by the difference between the temperature inside and outside that may save energy by avoiding very cool or hot air (respectively in winter or summer time) to enter the building.
- Mechanical ventilation could be controlled by real occupation sensors, reducing flow rate when the dwelling is unoccupied.

Load efficiency indicators : progress is needed

By specifying a standardized demand, some national systems can really compare electricity consumption expressed in Watt directly.

Some other national habits try to characterize the product with less details about the demand. The flow is an important functional parameter. The ratio of Watt spent to flow generated seems a logical choice for efficiency. However it depends on the pressure drop to be generated: a conventional value may be admitted for selection that will be variable on site. The SFP (Specific Fan Power) defined in **non residential** EN standard as a performance indicator is not the perfect indicator. It is a ratio between the electrical consumption and the flow, expressed in W per m³/h. Let's give examples.

SFP is not a perfect indicator of fan efficiency first because the consumption not only depends on the flow but also on the pressure difference we have to create. However it is a good indicator of the total ventilation system efficiency, if all the elements are provided by the same manufacturer and that there is no design or variation possible on the field. To prove it is not an indicator of fan efficiency, let's consider an innovative system that could request less pressure difference and not be based on an efficient fan: SFP would say it's efficient.

Also there is a limitation on SFP as an indicator because the ventilation system can realise numerous regimes according to the demand downstream. SFP will then be computed for a design point at very high flow and the adaptation of the system to the –most common- lower flows will not be represented.

We can also understand the problem of defining an SFP for double flow: the SFP is the total electricity used in the ventilation system divided by the largest of the flows (fresh air or exhaust) or it can be defined as the electricity used divided by the sum of both flows. SFP is used as a target for a specific component, like an Air Handling Unit. So we will use it here for the fan of a mechanical ventilation, but we know the limitations.

The possibilities of audit given to the end user in an existing building

Natural ventilation in buildings per se may be an energy conservation strategy, based on the proper interaction between building envelope characteristics (air permeability, presence of operable windows, etc.) and internal layout of the building (presence of convective paths). It needs very professional design. But natural ventilated buildings with poor air tightness when converted to artificial air conditioning or artificial ventilation can become huge energy consumers.

In case of poor design, poor installation, progressive degradation or failure, the signals that the consumer receives are weak and may be interpreted in many, and not with the real cause:

- condensation in some parts of the building shell may be interpreted as resulting from a local defect in insulation, as a lack of fresh air inlets, as resulting from infiltration not from condensation, as an effect of a high latent load (rice or pasta cooking), etc.
- odours may have various causes, exist even in case of ventilation, and are subject to individual interpretation, etc.

Here again we should say that the lack of clear functional feedback (the signals that the consumer receives are not easily associated to the causes) and the lack of proper system design has higher energy impact on the side of thermal energy than on the side of electricity consumption. One useless m³/h of flow may generate 0.3 Wh of electrical consumption, 2.5 kWh/year. The same useless m³/h of flow may waste 20 kWh/ year in heating demand and 2 kWh in cooling demand (computation based on a Degree Day approach). In fact the electricity gain may very well not appear (since the package is anyway oversized and will remain oversized) while the thermal energy will really be demanded.

Some ways exist to check the pressure field in an operated building, as blower doors or other infiltration measurements (EPFL LESO, Swedish companies). If this is not regulated (all countries except Norway and Sweden) the user never asks for a diagnosis of ventilation. Only in case of large problems of condensation a diagnosis may be requested for insurance reasons. The existing CEN standard for ventilation inspection is not used presently because there is no request of ventilation inspection in EPBD.

3.2 End-of-Life behaviour

Identification of use of second hand auxiliary inputs during product life

When the end user puts some air filtering in the specification, it generates additional energy demand and expenditure (and material flow) in changing the filters. There are stable definitions about testing and rating of filters (EN779 and EN 1822, built from Eurovent recommendation 4/5). By order of efficacy we find:

- filters tested with gravimetric method and rated from G1 to G4, that the experts (Uniclimate brochure) recommend to introduce every time we move air, which is not the case presently,
- filters tested with opacimetric method, rated from F5 to F9, and the experts recommend at least F6 for Internal Air Quality and before a fan,
- very high efficiency filters rated from H10 to H14 and from U15 to U16.

Let's remark that a filter without an automatic clogging detection or a strictly monitored maintenance procedure is not a filter. One Pascal of additional pressure drop on a filter generates an overconsumption of 15 kWh (1 or 2 Euros) according to (Eurovent 2004). Filters with the same quality may display a difference of 40 Pa in pressure drop, or about 50 Euros, more than the cost of the filter! There is a computation procedure provided by Eurovent for LCC calculation of filters, and namely maintenance schedule optimisation.

Economical product life (=actual time to disposal) is 10 years according to the indications that we were given and most waste seems to flow into the regular disposal system. The installer of the new equipment decides about this and not the actual consumer because of the lack of awareness that we mentioned. Repair- and maintenance practice (frequency, spare parts, transportation and other impact parameters) have not been documented by stakeholders. We only observe that there are spare parts for the extracts not for any other subsystem.

3.3 Local Infrastructure

About hoods with a fan integrated, there are problems of connection to the outside about which there are national regulations. At least in France, the danger associated with connecting them to gas fumes

exhaust or any other pre-existing chimney is estimated high: inversion of pressure, corrosion, etc. Since mechanical ventilation is a very common solution as a result of building codes, the extraction systems include now the offer of specific hoods without motors to be used in kitchens.

Noise is an aspect of ventilation: noise coming from the fan through the ducts, from outside through air inlets, noise travelling between rooms or apartments through ducts, etc.

Some countries (France since 1994) impose an obligation of results in terms of noise added. This obligation of results is to remain under 30 dB(A) for ventilation and under 35 dB(A) for air conditioning.

Then some local noise already exists. Noisy zones (close to airports, highways, etc.) are more frequent than usually considered. In those zones the inlets for fresh air (later extracted by the ventilation system) may be a source of internal noise. A comfortable solution would be to move to balanced double flow with centralised treatment of acoustics before fresh air distribution, which proves to be a more costly solution. The single flow extractor can also generate noise and vibrations but there are silencers and anti-noise couplings available for the extraction grilles.

The level of know-how/training of installers is low because this part of the job is not well separated and well paid. Installation guides for good practice exist in France. We should mention the two UK guides for installers (SAP, 2006)

Task 3 summary

Consumer behaviour is often characterised by lack of awareness about the ventilation equipment which is usually continuously in use. This lack of functional feedback can be seen as a barrier to eco-design measures, or even to the simplest maintenance and design operations.

Ventilation consumption varies accordingly to the pattern of the demanded flow rate. Control scenarios have been identified and will be named in the following manner:

- continuous use, CONTINUOUS
- control by an on/off switch, ON/OFF
- same with two, three and four flows and corresponding speeds offered to the user, MULTI SPEEDS
- continuous speed control (mostly obtaining constant pressure drop over fan), named VARIABLE SPEED .

The degrees of freedom about the speed described here are user related. Every ventilation system has various operating points according to control or to atmospheric condition. Electricity consumption of double flow systems will also be sensitive to the pressure balance and its correct maintenance in time. Because of varied pressure regimes, a SFP with a single point (flow, DP) may not allow correct comparison of ventilation products.

The degrees of freedom of the fitter are:

- the choice of the product;
- the installation of switches or speed selectors for the user ;
- the choice and installation of products at several speeds, the flows being chosen by the installer;
- the choice of a product taking account of the presence (in residential sector: H2O content).

Filter maintenance is an important issue, highly cost effective to maintain real life performances of ventilation products.

Specific care must be taken with hoods connections on the aeraulic circuit. Noise limitation indoors is a specific constraint to be taken into account for the product design. In specific noisy zones, the transmission of noise from outdoor can also be a constraint for the product design.

4 TECHNICAL ANALYSIS EXISTING PRODUCTS

4.1 Production phase

Before starting this section, we want to thank the manufacturers who have largely contributed to our data basis.

Data available

We have five ICV. ICV#1 that has been extracted from the lot 11 study. We have estimated the electrical power to 86 W. Four other BOMs of ICV have been made on purpose by manufacturers. We have chosen to interpret the BOM provided by manufacturers as a function of electrical power used by the product allowing us in part 5 to generate a BOM for an average product in each category without consideration of the maximum flow through the product (not always available for 0 Pa, arbitrary for any other reference pressure).

Table 4-1: Bills of material of various fans for residential ventilation

| | DV1 | DV2 | ICV1 | ICV2 | ICV3 | ICV4 | ICV5 | DV3&HR |
|----------------------|-----|-----|----------------------|------------|------------|-------------|------|--------|
| Type | AC | AC | Centrifugal (Lot 11) | AC forward | EC forward | EC backward | | |
| Pelec | 8 | 23 | 86 | 135 | 66 | 78 | 62 | 26 |
| Aluminium | 6 | | | 1613 | 1486 | 108 | 9 | 35 |
| Steel | 280 | 452 | 1048 | 1115 | 505 | 467 | 999 | 2199 |
| Electronics | | 17 | 72 | 5 | 86 | 87 | 81 | |
| Iron | | | | | | | | 127 |
| Bulk Plastics | 56 | 457 | 505 | 79 | 198 | 298 | 2450 | 3069 |
| Tech.Plastics | 224 | 67 | 604 | | 148 | 146 | | 148 |
| Copper | 34 | 2 | 300 | 196 | 93 | 109 | 135 | 215 |
| Brass | | | | 3 | 5 | 5 | 11 | 63 |
| Others | 0 | 2 | 1001 | 29 | 9 | 0 | 1 | 3 |
| Total | 600 | 997 | 3530 | 3040 | 2530 | 1220 | 3686 | 5859 |

Study of DV products

Let's now extract some lessons about each category. First Decentralised Ventilation products.

Figure 4-1: Bills of material of various DV fans

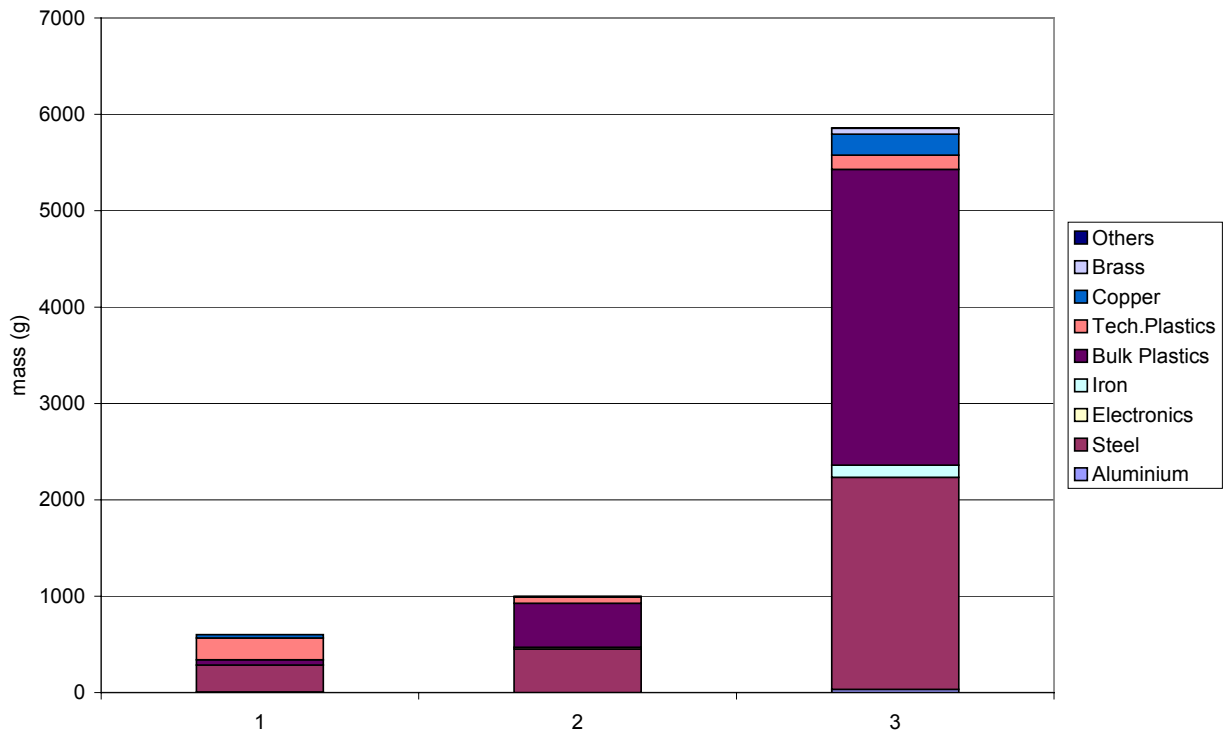

The two DV materials have a comparable weight if we take power into account but the content is different : more plastics in product DV2, which is better “clothed” because it is made to be visible. The product with heat recovery is very visible (more plastics) and receives the addition of a heat exchanger made of steel.

For DV hoods manufacturers have not yet proposed BoMs. Due to the nature of the service expected, the kitchen hoods seem to include a high proportion of plain steel, while the DV fans can be made significantly (except motor) of plain plastics, as the existing BoMs show.

Study of CV products

Coming to ICV, we have ranked them in the graph in function of their electrical power (ICV5, then 3, 4, 1, 2).

Figure 4-2: Bills of material of various ICV fans

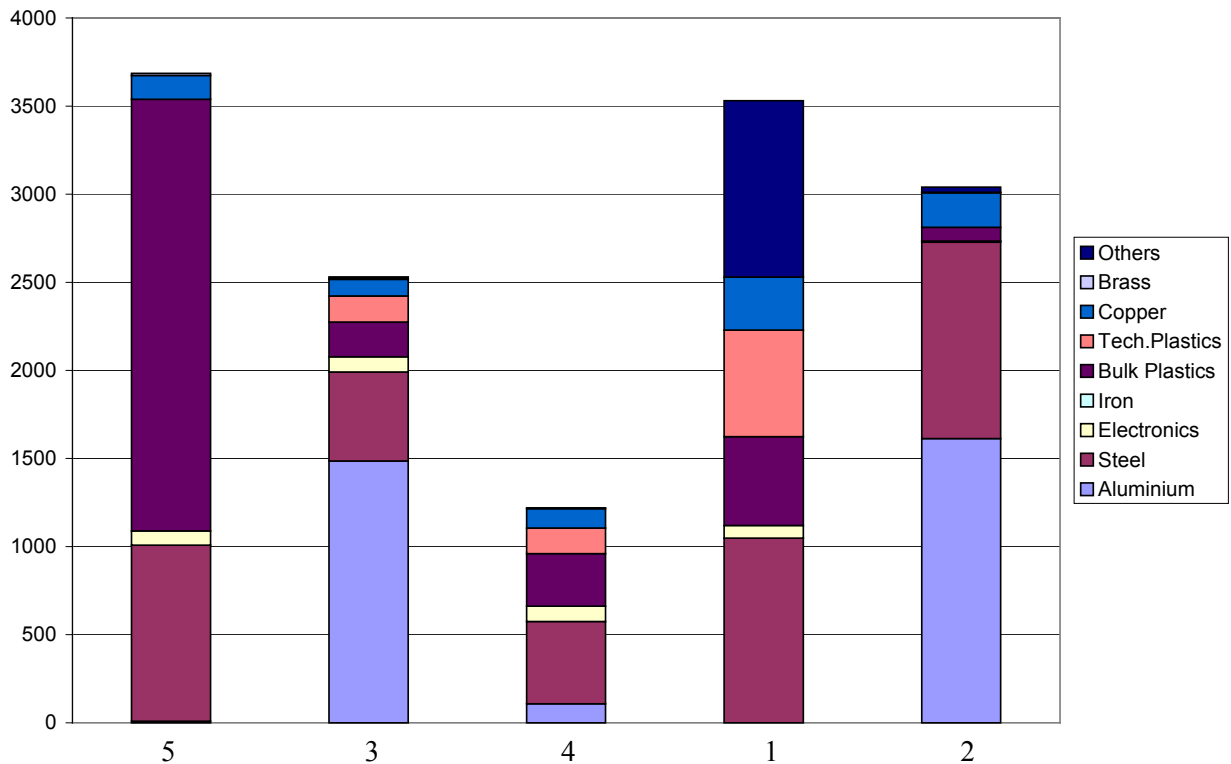

The product ICV4 (third on the graph) is a real environmental challenger and has been designed as such by its manufacturer (efficient motor, efficient fan, little materials). We will withdraw it from the definition of the baseline.

For CCV, the metals seem more important than for ICV, namely steel, because of fire regulations, and maybe also because of exposition to outside.

Extrapolation methods

We have used our data base of products to correlate the total mass with the flow (this time the absolute maximum flow not the BEP) or the electrical power. The linear shape obtained would allow to compute simply from the area ventilated in task 2 a total air flow or a total electrical power and so a total mass of products either sold one year or in service one year. Here is the graph for Pelec:

Figure 4-3: Relationship between electrical power and mass of the product, all products in scope

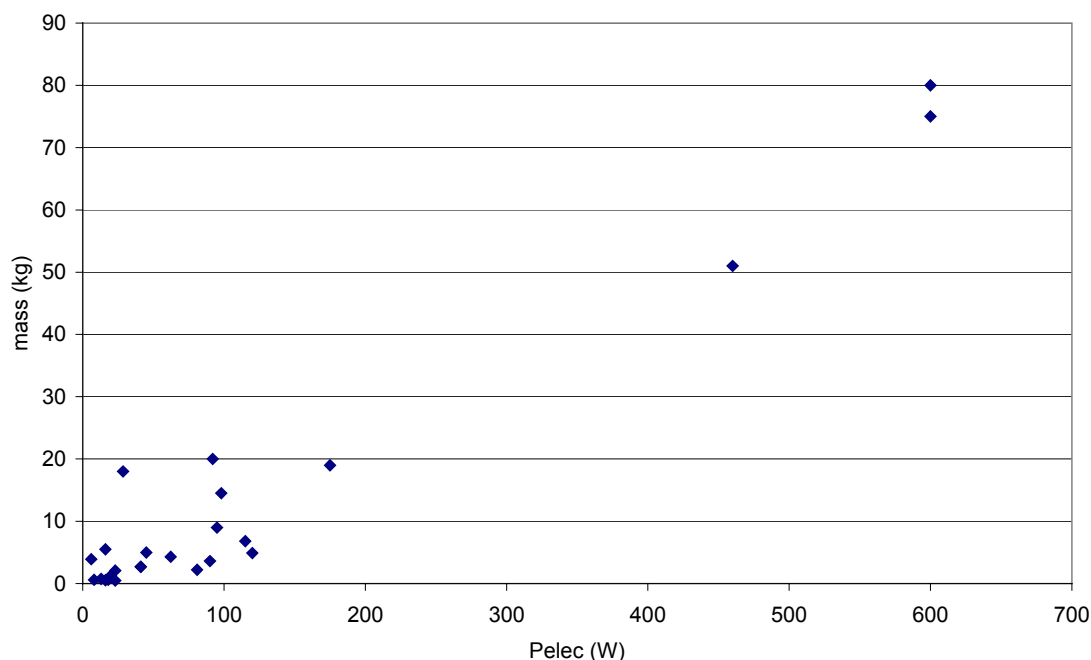

We have approximately 116 grams per W and half for window and wall fans. After computing the mass of the reference product we will compute its materials content by using the ratios extracted from the previous work and shown on table 4.2.

Table 4-2: Bills of material of various fans as percentages of total mass

| | DV not hood | DV hood | DV&HR | ICV | ICV&HR |
|----------------------|-------------|---------|-------|------|--------|
| Aluminium | 0% | 0% | 1% | 24% | 24% |
| Steel | 46% | 80% | 38% | 29% | 40% |
| Electronics | 1% | 1% | 0% | 2% | 2% |
| Iron | 0% | 0% | 2% | 0% | 0% |
| Bulk Plastics | 32% | 10% | 52% | 25% | 14% |
| Tech.Plastics | 18% | 9% | 3% | 6% | 6% |
| Copper | 2% | 2% | 4% | 6% | 6% |
| Brass | 0% | 0% | 1% | 0% | 0% |
| Others | 0% | 0% | 0% | 8% | 8% |
| Total | 100% | 100% | 100% | 100% | 100% |

4.2 Distribution phase

To our knowledge most products are manufactured in Europe, very often not in the “origin country of the brand”. Manufacturers distribute directly the products to gross marketers (regional) DIY shops and installers, so that there is no reason to change base assumptions of the Ecoreport for the distribution phase. The mass is known thanks to correlation with nominal air flow rate in Figure 4.2.

4.3 Use phase (product) –Energy Efficiency at Full Load (FL)

Assessment of resources consumption during product life (mostly electricity) should be made in off-standard conditions, i.e. at variable load. In this case, variable load implies various operating points. Only some cases can be computed in the constant load conditions of the standard. Encountered situations are gathered in the table below; non existing situations have been marked with -.

Table 4-3: Computing energy consumption, characteristics of operation – constant or variable load

| Calculation process at... | CONTINUOUS | ON/OFF | MUTI SPEEDS | VARIABLE SPEED |
|---------------------------|---------------|---------------|---------------|----------------|
| DV | constant load | constant load | variable load | - |
| ICV | constant load | - | variable load | - |
| CCV | constant load | - | - | variable load |
| HCV | - | constant load | - | - |
| DV&HR | constant load | - | variable load | - |
| ICV&HR | constant load | - | variable load | - |
| CCV&HR | constant load | - | - | variable load |

4.3.1 Definition of characteristic lines and BEP (Best Efficiency Point)

The product under consideration has an infinite number of operating points represented graphically by pairs (flow generated, pressure difference generated). Practically manufacturers provide diagrams with the full characteristic lines (various lines when the frequency or voltage can be varied to generate various rotation speeds) and the efficiency lines, which in theory are perpendicular to the characteristic lines. When the efficiency is not provided one can easily compute from the characteristic line the hydraulic power generated, ΔP times the volumetric flow, called P_{hydr} here, and then the ratio to electrical power gives the efficiency (P_{hydr}/P_{elec}). Hereunder is presented an example of characteristic lines and equal efficiency lines.

Figure 4-4: Example of characteristic line of a ventilation product

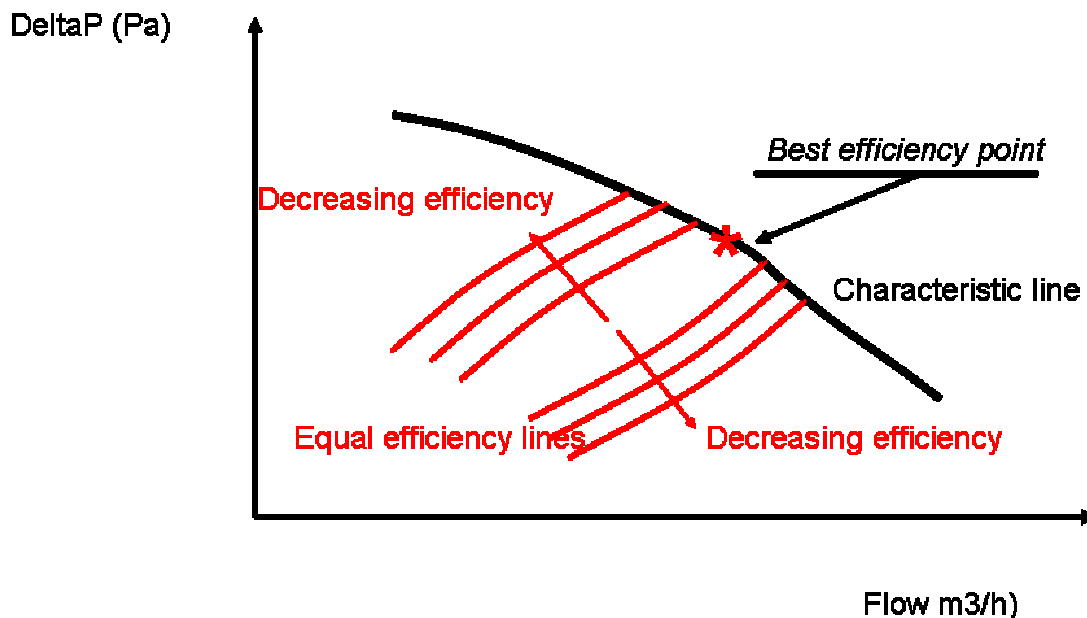

4.3.2 Various aspects of characteristic lines

Decentralised ventilation units

The decentralised products DV have often a characteristic line of the following type (a):

Figure 4-5: Characteristic line of decentralised ventilation product of wall type

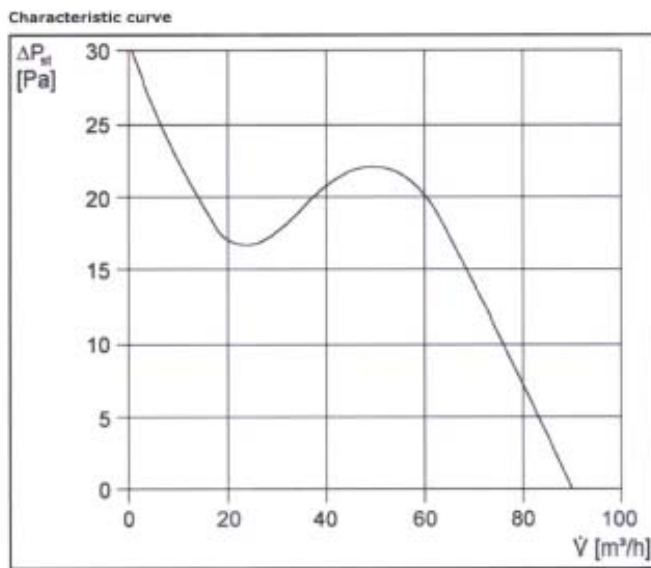
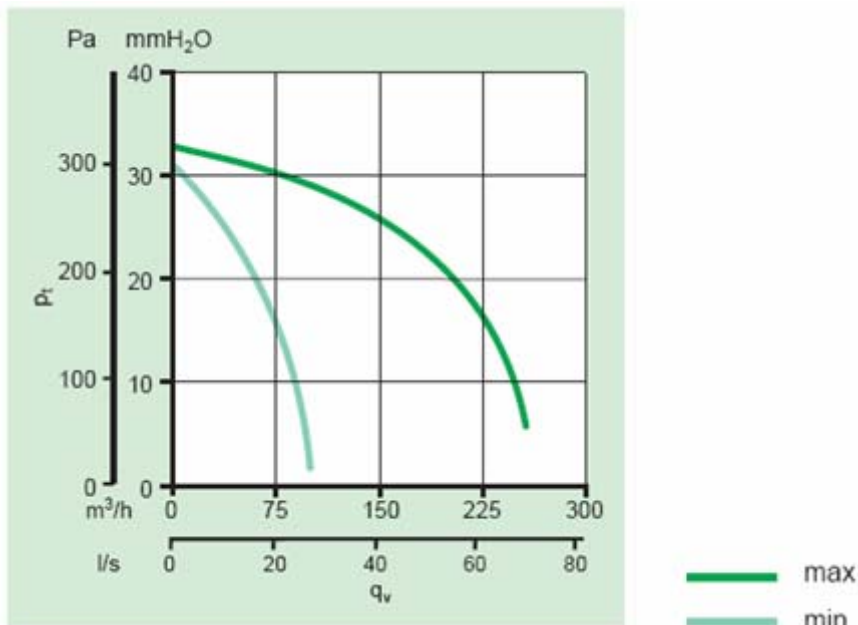

Figure 4-6: Characteristic line of decentralised ventilation product of range hood type



Such a range hood extractor reaches relatively high pressures (to be able to combat filter headlosses) at either speed and unknown chimney.

Centralised ventilation units

As a result of the work of generations of engineers the regular centralised extractors ICV in continuous use display a simpler characteristic line of type (b):

Figure 4-7: Characteristic line (Type b) of ICV product

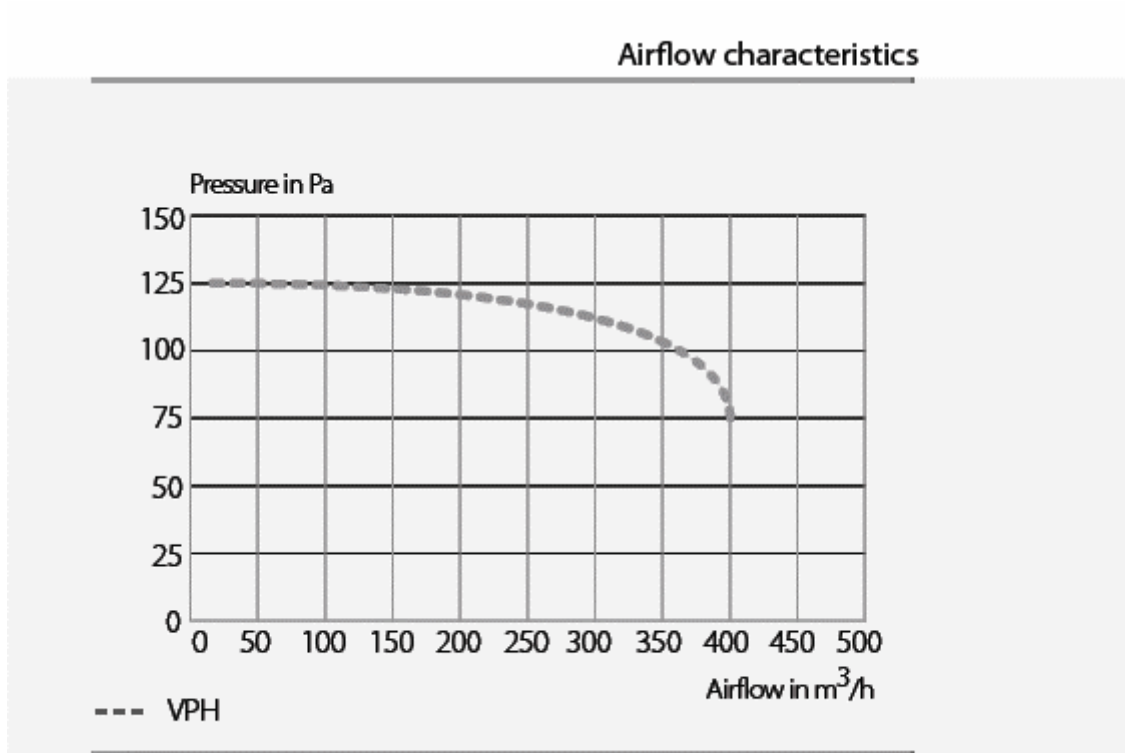

Some of the ICV have two or three speeds between which the user has to make a selection by using a switch; we call the corresponding lines type (c):

Figure 4-8: Characteristic line (Type c) of ICV product with two speeds

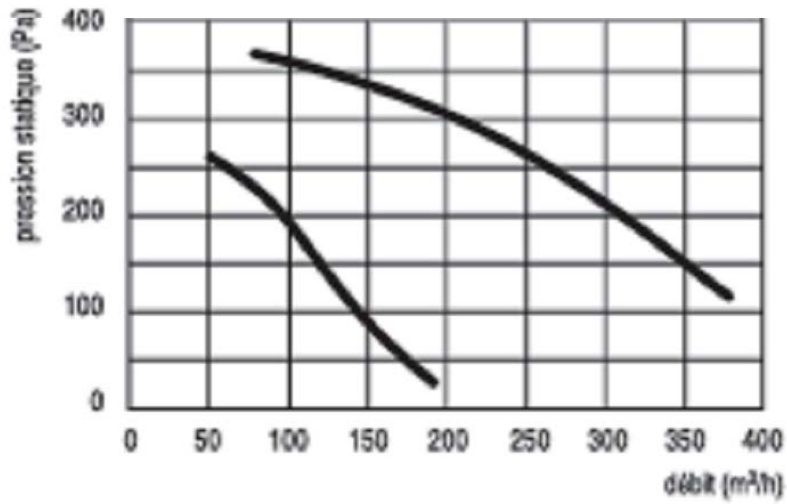

Some products are worked out so as to have a large zone of pressure differences in which the flow is constant (the vertical part of the three lines hereunder), and display a characteristic line of type (d):

Figure 4-9: Characteristic line (Type d) of products with a large zone of pressure differences in which the flow is constant

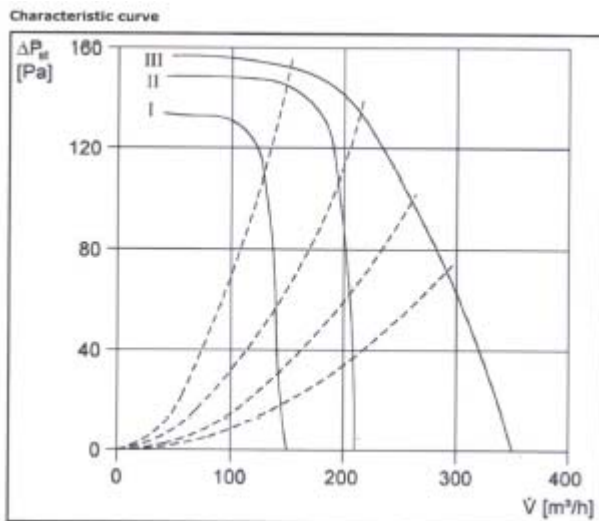

On the opposite, there are products with a very horizontal characteristic line, namely (but not only) for CV, to guarantee an available pressure, type (e):

Figure 4-10: Characteristic line (Type e) of products that “guarantee” a constant pressure difference

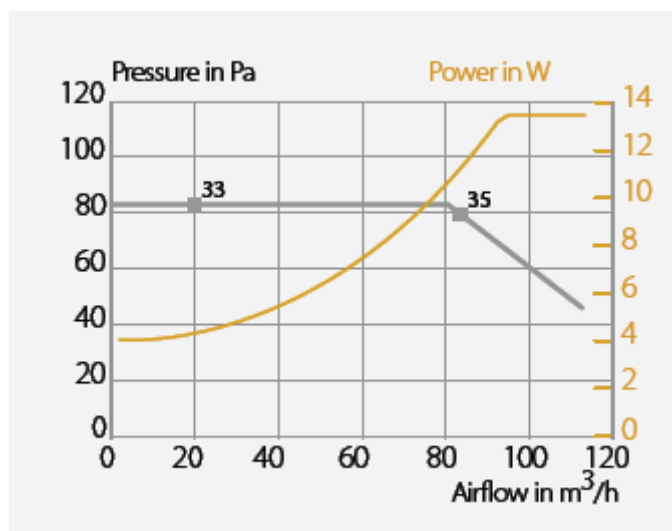

Finally by varying the speed one can obtain a perfectly horizontal line. If the pressure sensor is located at another point of the circuit not at suction point, we can obtain a constant pressure at that point when the flow varies. The horizontal lines in the following graph are themselves characteristic lines obtained by automatic control that we will call type (f) and which reduces noticeably the total electrical consumption:

Figure 4-11: Characteristic line (Type f) of products with variable speed

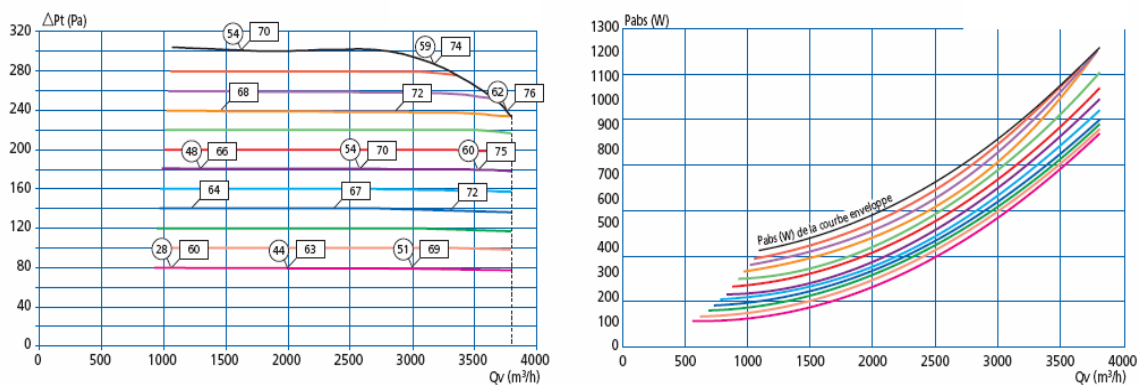

A further variation of this line will be presented in the BAT analysis in task 6 and is called type (g).

Balanced flow units

In front of the problem of representing both air circuits in case of heat recovery manufacturers use two options.

Some manufacturers and the standard¹¹ represent two sets of “classic” characteristic lines, like the following (here with various possible speed settings):

¹¹ EN 13141, Ventilation for buildings - Performance testing of components/products for residential ventilation-Part 7: Performance testing of mechanical supply and exhaust ventilation units (including heat recovery) for mechanical ventilation systems used in a single dwelling - Sept 2004.

Figure 4-12: Characteristic line of products with heat recovery (here also with multi speed)

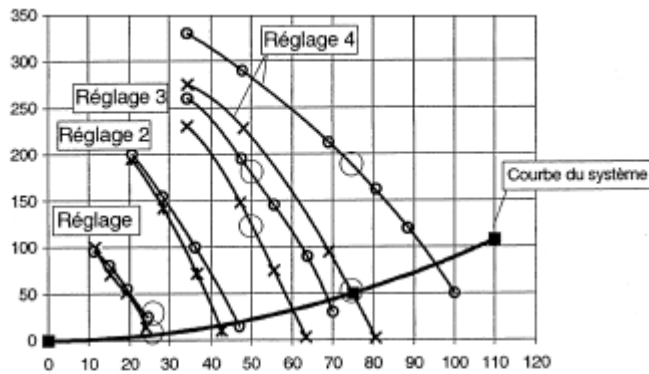

Key

- Operating point, decl. max. air flow 75 l/s, air flow 58 l/s, min. air flow 25 l/s
- o Exhaust air
- x Supply air
- 1 Air volume flow in dm^3
- 2 Pressure of the unit, Pa
- 3 Setting 1
- 4 Setting 2
- 5 Setting 3
- 6 Setting 4
- 7 System curve

Some consider that the flow on both sides is exactly the same, hence only one line is needed (even if the product is a double flow product with HR).

Figure 4-13: Characteristic line of products with heat recovery, with supposed equal characteristic for inlet and outlet air flows

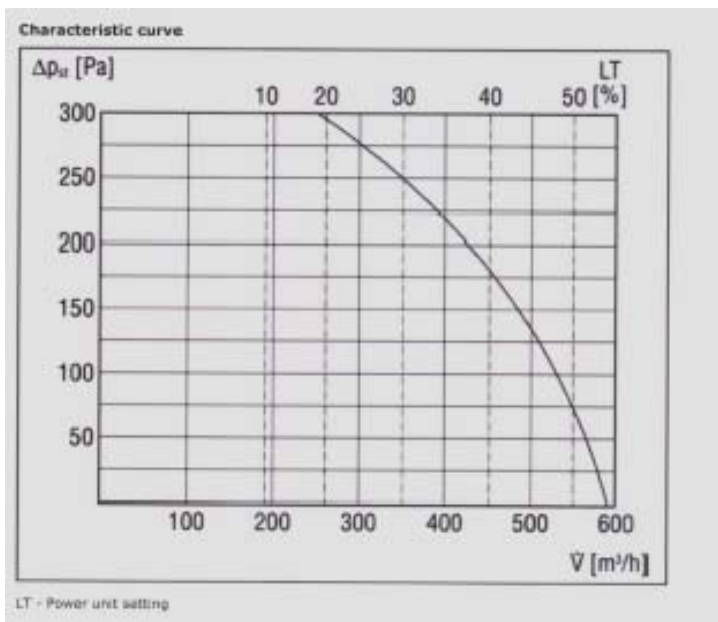

Some “lump” both circuits and give data under the following form.

All these presentations will not generate problems in the future calculations of SFP or efficiency.

Figure 4-14: Characteristic line of products with heat recovery, with supposed equal characteristic for inlet and outlet air flows, complete performance map

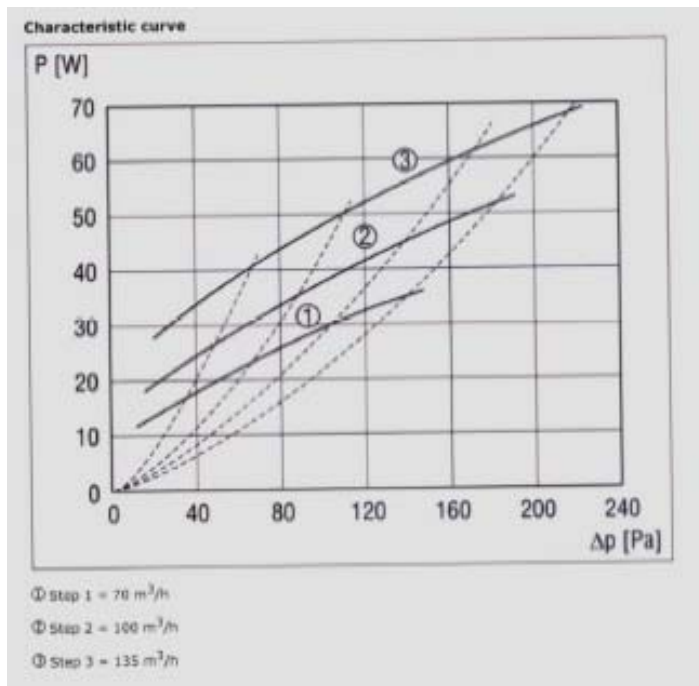

Hybrid ventilation units

Assistance fans to natural ventilation display a slightly different curve from regular extractors and a very low pressure difference, type (h):

Figure 4-15: Characteristic line (type h) of fan assisted natural ventilation products

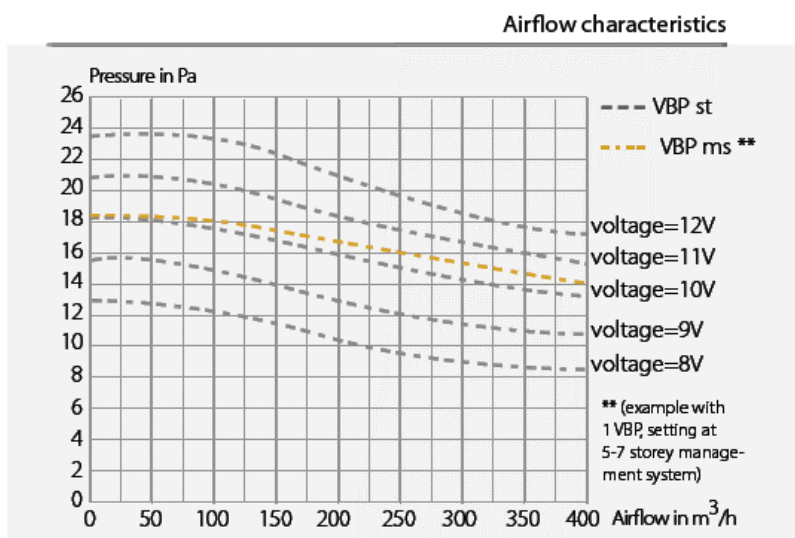

4.3.3 How to select one representative point on the product characteristic line (definition of one operating point representative of Full Load : FL)?

In this part we consider the constant load conditions. In the next part we shall consider the variable conditions. Even at constant flow, the definition of an energy consumption indicator is not easy because the result given by the testing standard is (with reason) a line, along which performance varies, and also electricity consumption. We should select one point.

There are typical design conditions of the products, corresponding to various flows and pressure difference demands in national building codes. So the natural tendency of practitioners is to create many specific categories, namely in correspondence with the building code of the country where they operate. For each category, we have one typical operating point for which SFP or efficiency or electrical consumption can be defined. This is not really a characteristic of the product, so we will discuss this approach.

We want to propose hereunder one way to escape this influence of national building codes. We think it solves the problem but we investigate also the other approach, due to its large acceptance. So we find two options: in option (A) we try to decide on design points as common as possible between countries, in option (B) we admit the product was designed for a specific point and we judge it on that point.

Option (A): the usual approach of defining national pressure/flow “duties” on which the product is judged

National building codes specify the “duties” of ICV like in the UK SAP-Q or French Th-C: length of ducting, flow, how many hours in each mode, type of air inlets, etc. The products are optimized for that set of specifications and an average electricity consumption is defined. However it still depends on the size of the house or flat, and should be extended to other ranges of products (decentralized, collective), by defining more and more specifications.

Let’s take an example to explain what is defining the “duty” of one product: the extractor for one French dwelling. Each extraction point demands 15 m³/h except the kitchen which demands two flow values: 45 m³/h or 135 m³/h. The grille needs an under pressure 90 Pa < ΔP < 160 Pa. Let’s say 100 Pa to generate one single value. It operates 2 h over 24 h at high flow. What we have presented as an example of “duty” represents the habits of one country and should be harmonised between the countries if we want to apply this approach.

An existing study made an attempt to harmonise such definitions over EU countries, despite of the contradictions between the various building codes (Vialle, 2006, and 2007). It uses the SFP as an efficiency indicator. The study did not succeed completely because the systems in use were not the same in the EU countries, resulting in different expectations about pressure and flows from the various experts interviewed.

The traditional SFP seems not perfect to compare products because it does not correct for the impact of pressure differences demanded in the standardized duty and so may be prejudicial to some products with a higher pressure generation ΔP. Even if we defined a set of “duties”, the end user would have still to deal with a complexity of figures, 10 kWh/year/m³ for one duty not being like 10 kWh/year/m³ for another duty, e.g., because of the difference in pressures, not in efficiency of products.

We can imagine to edit SFP values for steps of 50 Pa and 100 m³/h width. Such a grid of pressures and flows makes the result independent from building codes, but is paid by complexity of information. Even when admitting the complexity the system does not provide the accuracy needed even for a simple labelling system. Two products belonging to the same class of pressure provided, for instance 100 Pa, can be as different as one providing 75 Pa, and one providing 125 Pa. If we admit they have the same efficiency, the second one will consume 66 % more than the first one, and its SFP will be 66 % higher. The inaccuracy seems to object to the use of the SFP system in a product labelling system.

However we can propose the solution of indexing the SFP requirements to P_{max} , the maximum pressure difference that the product can generate.

Furthermore, we can imagine also to base the selected pressure for reporting SFP on the maximum pressure P_{max} , for instance $P_{max}/2$ or 75% of P_{max} . We found that due to the variety of shape of characteristic lines this could be unfair to some types of equipment, namely the ones with a flat curve, which are energy efficient at part load. However it would be good to base a potential SFP rating on a reference pressure extract from the product, not completely coming from outside. We will give another example. Note that some manufacturers curves are not drawn up to P_{max} .

To be positive and try to use the system proposed, there are three values of SFP that seem logical: SFP at 0 Pa, like in a fan across a window (or also a comfort fan inside the space), SFP at 100 Pa for a number of countries and systems, SFP at 150 and 200 Pa for some other countries and systems.

An option to avoid this complexity is to summarise the duty into one figure of severity: the hydraulic power to be generated, ΔP times the flow, called Phydr here, and to reduce each product to an efficiency (Phydr/Pelec). Usually the professionals are expecting the use in our study of the SFP (Specific fan Power) an index defined for non residential buildings in the EPBD standards, not of the efficiency. However the efficiency has been widely used in the history of fans and is still available in many cases in manufacturers' documents. It can be readily computed from existing standard testing results.

Option (B): a possible approach of basing performance comparisons on the "best efficiency point"

Another possible approach is based on a higher confidence on professionals: let's assume they generally design or select an adequate product. We don't have to check the product against specific duties, we don't have to harmonise design values between building codes. If a given product is put on the market, we assume it has been designed and selected according to its qualities for a given duty that we don't want to define from outside. Comparing products is comparing the best point of each characteristic line (certainly related with a specific objective), not comparing an ordinary point defined by arbitrary duties.

One computes easily the point with the highest efficiency on the line, which is not the point with the highest hydraulic power generated (since the absorbed electrical power varies along the line). The hydraulic power to be generated, ΔP times the flow, called Phydr, allows to map efficiency (Phydr/Pelec). If a choice is made for SFP as index, it could also be the SFP at that point which has been certainly chosen with care by the manufacturer. We can also make the choice of keeping the value of the best efficiency itself in % as the EEI (Energy Efficiency index) for the sake of consistency.

An additional benefit of option (B) is avoiding the comparison between centralised and decentralised solutions. The building codes request what the MS think necessary, either one or the other (or natural, or hybrid). We are only dealing with the issue of efficiency of the product: how to improve it, without changing its adaptation to the rest of the building features.

Defining the nominal or maximal pressure and flow of a product

We must initially characterize the "full load" (FL). The speed being maximum, (by automatic control or manually), one has a characteristic line where there are several possible definitions of the "nominal flow" and the "nominal pressure difference".

It will then be necessary to choose some flows for the characterization of partial load in % of the "nominal" flow. In the same manner to compare materials one needs to say with which "nominal" pressure they function.

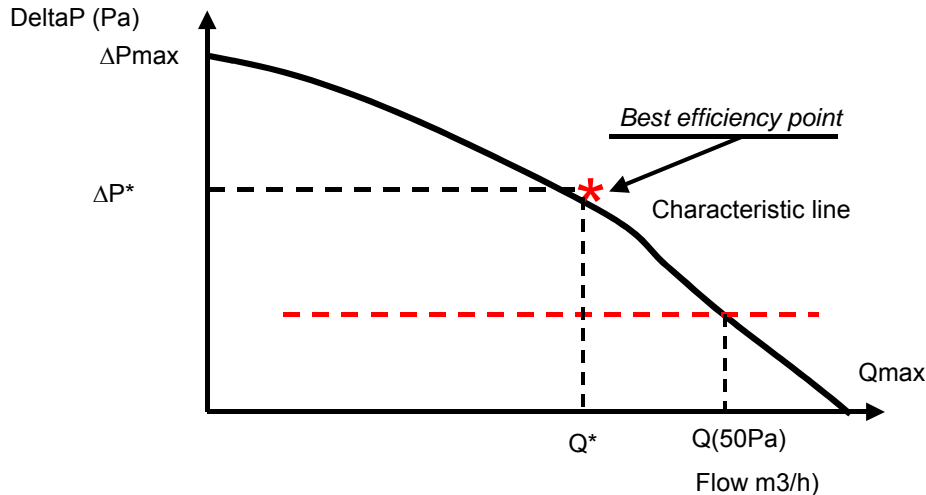

The maximum flow Q_{max} (null depression) and the flow with 50 Pa appearing to us arbitrary, we can call nominal flow Q^* , the flow at the BEP (maximum of output) and to call reference pressure P^* and not P_{max} . We have many possibilities that we have to test in practice

4.3.4 Options for EEI_{FL} (Energy Efficiency Index at Full Load) scenarios

We can define four scenarios by crossing the options just defined in 4.3.1 and 4.3.3.

Option (A) -Scenario 1 SFP at 0, 100, 150, 200 Pa

For each point the laboratory reports P_{elec} , flow, $SFP = P_{elec}/flow$

There is a line of SFP (for instance SFP at 100 Pa) function of P_{max} to which compare the specific equipment.

Option (A) -Scenario 2 Efficiency at 0, 100, 150, 200 Pa

For each point the laboratory reports P_{elec} , flow, ΔP , $Phydr = flow \times \Delta P$, $Efficiency = Phydr/P_{elec}$

It can be used directly for performance comparison.

Option (B) -Scenario 3 SFP at BEP

For this point the laboratory reports P_{elec} , flow Q^* , pressure ΔP^* , $SFP = P_{elec}/flow$

There is a line of SFP function of ΔP^* to which compare the specific equipment

Option (B) -Scenario 4 Efficiency at BEP

For this point the laboratory reports P_{elec} , flow Q^* , pressure ΔP^* , $Phydr = Q^* \times \Delta P^*$, $Efficiency = Phydr/P_{elec}$

It can be used directly for performance comparison.

4.3.5 Testing the options on one example

We applied this rationale to a number of very different products. Let us show the computational steps for one single product: the typical extractor with a type (c) line. First we can see it has two speeds (upper and lower line) and a manual switch to request high speed. So we tested the approach on each speed. High speed demands 73.1 W input while lower speed demands 27.4 W input.

Figure 4-16: Typical ICV characteristic line with two speeds

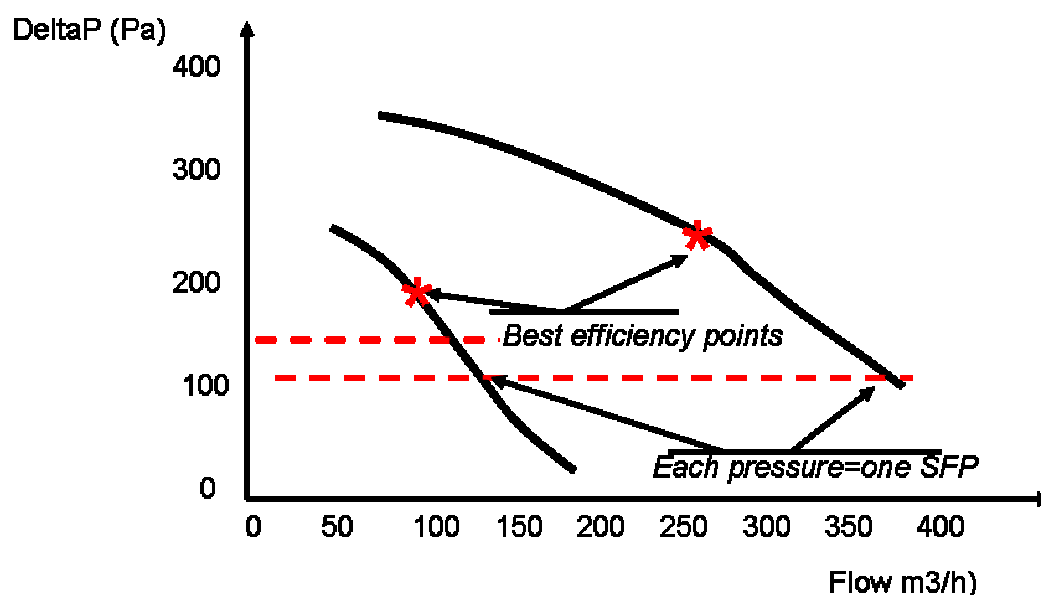

Option (A) is represented by horizontal lines corresponding to an arbitrary pressure demand. Since the pressure demand is not at all harmonized between the national building codes this generates the numerous SFP corresponding to those specified design conditions. Option (B) introduces no design conditions and looks for the optimal operating point (called BEP, Best Efficiency point) at each speed (*), assuming the products were designed by the manufacturer or will be selected by the installer for those conditions. Table 4.2 shows the calculation based on figure 4.15.

Table 4-4: Computation of scenarios in options A (given conditions) and B (best efficiency point)

| Flow rate m3/h | DeltaP in Pascal at low speed | P elec. In Watt | Efficiency at low speed | SFP at low speed | DeltaP in Pascal full speed | P elec. In Watt | Efficiency at full speed | SFP at full speed |
|----------------|-------------------------------|-----------------|-------------------------|------------------|-----------------------------|-----------------|--------------------------|-------------------|
| 50 | 250 | 27.3 | 12,40% | 0,56 | - | | - | - |
| 100 | 200 | 27.4 | 19,84% | 0,28 | 360 | | 12,16% | 0,73 |
| 150 | 100 | 27.5 | 14,88% | 0,19 | 340 | | 19,38% | 0,49 |
| 200 | - | | - | - | 300 | 72.0 | 22,80% | 0,37 |
| 250 | - | | - | - | 270 | 72.1 | 25,65% | 0,29 |
| 300 | - | | - | - | 200 | 72.2 | 22,80% | 0,24 |
| 350 | - | | - | - | 150 | 72.3 | 19,95% | 0,21 |

In applying systematically option (A) to the products in our data base we found some practical problems that we have to report. SFP by itself does not show any optimal value and trying to improve it leads to the point with less pressure demand, as we were expecting. Usually the low and high ΔP are not shown, like here. Some individual centralised products and all decentralised products don't reach the 100 Pa threshold necessary to apply option (A) with this very usual value. Also a limited number of collective centralised products are over the 100 Pa line and the suggested SFP cannot be computed at full speed, like here. Obviously the hybrid ventilation products and the products with heat recovery are not easily covered by scenarios derived from option (A).

Furthermore some products display lower pressure demands (because the corresponding extracts are not sophisticated) and have very low SFP values without any effort in energy efficiency of the motor/fan unit.

What do the various scenarios say about the product used as example?

Expression of results in Option (A)-Scenario 1 SFP at 0, 100,150, 200 Pa

“In a country with a pressure demand of 200 Pa (at full speed), the product has an SFP of 0.24. In a country with a pressure demand of 150 Pa, the product will deliver 350 m³/h at full speed and 125 m³/h at low speed. The associated SFP will be 0.21 and 0.24. In a country with a pressure demand of 100 Pa (at low speed), the product will deliver 150 m³/h and the SFP will be 0.19. Having in mind the Pmax, this SFP is better/worse than average...”

Expression of results in Option (A)-Scenario 2 Efficiency at 0, 100,150, 200 Pa

“In a country with a pressure demand of 200 Pa the product will have an efficiency of 22.8% and operate always at full speed. In a country with a pressure demand of 150 Pa, the product will have an efficiency of 20% at full speed and 17% at low speed. In a country with a pressure demand of 100 Pa (at low speed), the product will have an efficiency of 15%. This efficiency is better/worse than average.”

Expression of results in Option (B)-Scenario 3 SFP at BEP

“In order to characterize the product itself and not its conditions of use, we keep the point being the most efficient on each line. At full speed SFP at best efficiency point is 0.29, at low speed it becomes 0.28. We may assume the manufacturer has designed the product having in mind some building codes, but we don't specify them. After correcting for the ΔP , this SFP is better/worse than average.”

Expression of results in Option (B)-Scenario 4 Efficiency at BEP

“In order to characterize the product itself and not its conditions of use, we keep the point being the most efficient on each line. At the lower speed best efficiency is 25.6 %, at upper speed it becomes 19.84 %. We can assume the manufacturer has designed the product having in mind some building codes, but we don't specify them. This efficiency is better/worse than average”

In the rest of the study we will develop more option (B)-scenarios 3 and 4- which seems to us consistent with the product philosophy of ecodesign studies than option (A) –scenarios 1 and 2- which is more acceptable by professionals with present habits.

4.3.6 Extension of the full load scenarios to range hoods and products with heat recovery

We included in our rationale those two products. Let's explain how this is feasible.

We don't remind here the fact that Heat Recovery products have twice the duty of single flow extractors and that should be corrected for (for instance by multiplying the flow by a factor 2 before entering any of the proposed calculation routes).

In both cases (range hoods as part of DV and HR applied to DV and ICV) we have additional head losses, the filters or the heat exchangers. By using the characteristic line of the total product we are including the internal pressure losses, which is unfair if we compare SFP or efficiency with any other product without the same headlosses. The first idea is to generate a specific rating scale for each of those families but the level of heat recovery and the level of filtering are variable from one product to another, and directly associated with the level of head losses. One could suggest to make a measurement of pressure between the fan section and the section with head losses; this has to be tested but feasibility is not guaranteed (swirl and unstable flows are likely). Our final suggestion is to substitute at the time of testing the HR section by a pipe with negligible pressure drop on both circuit, in the case of HR products, and withdrawing the filtering elements, in the case of hoods, and to work on those modified characteristic lines. They are likely to become comparable with other products after that operation, and will not necessitate a specific scale. However there is a need of a few years of trials to be certain of that way of processing. For hoods it seems that the grease filtering element does not introduce such a perturbation that it has to be withdrawn.

Is it desirable to compare HR products with other products? We think this can be a fair comparison if the testing procedure without HR that we suggest works correctly. In the opposite situation, one can build a separate rating scheme function of the level of heat recovery, which is perfectly defined in EN standards. The main objection is the complexity and uncertainty that we generate by doing so for users of this innovative product and the fact that the main function of the product would not be ventilation but heating, or a mix of both. There may be also a “contagion” : the same could then be said about the systems like self adjusting air extracts and humidity sensitive extracts that lead to higher pressure demands (and so higher electrical consumptions) in order to save thermal energy by adjusting very closely the flow to occupation. On total the final decision should also take into account that heat recovery products are still marginal and seem to be under the EuP threshold.

Is it desirable to compare range hoods with other products? Having in mind that this is the most largely available ventilation device in Europe, it seems a good thing. If some technical problems prevent a direct comparison of efficiency with other products, a specific rating scale could be generated, but the objective seems to deserve that effort of harmonisation.

4.4 Use phase (system) –Energy Efficiency at Part Load (PL)

Here we identify and possibly quantify those product features that can modify the environmental impact not only of the product but of the system as a whole. So we consider variable conditions of flow and pressure demand. In the building codes, there are usually various regimes of functioning. So the efficiency or SFP for these various duties can be averaged (with the proper weighting) to generate one single figure. The need for harmonisation is becoming even larger.

4.4.1 Reduction of various operating points to one single PL value : an existing study

The study we mentioned previously (Vialle, 2006, and 2007) made an attempt to harmonise such averaging definitions over EU countries, despite of the existence of various building codes. We reproduce hereunder their very interesting approach: We got inspiration for our final proposal from this work of the French industry and the CETIAT technical center.

For ventilation systems used in single dwellings, the representative running points chosen correspond to the minimum and maximum speed of the fan for the maximum size of dwelling that the system is designed for.

Our comment: this is perfect if we are in the field of building codes (which by the way will give contradictory indications) but we are trying in the present study to characterise the product itself, with only one characterisation for all EU. We can drop the second half of the sentence.

For the ventilation systems used in multi-family buildings, two representative running points are chosen, one for the maximum air flow rate and one for the minimum air flow rate. For a system without any electronic control device, these points are taken on the maximum speed characteristic curve of the fan. The point corresponding to the maximum air flow rate, $Q_{v\ max}$ is determined according a reference total pressure $P_{vmc_refQ_{v\ max}}$ that is necessary to achieve in order that the ventilation system runs properly. This includes the pressure drop of the ductwork and the pressure to maintain for the operating of the extract terminal device. For ventilation systems using pressure controlled air extract devices, $P_{vmc_refQ_{v\ max}}$ varies according the air flow rate range of the fan unit. (see ranges in table 4.3). For ventilation systems with humidity controlled extract air terminal devices, $P_{vmc_refQ_{v\ max}}$ is 160 Pa. The point of minimum air flow rate $Q_{v\ min}$ is corresponding to a proportion of the maximum air flow rate. This proportion is chosen as 50 % in the case of a ventilation system using pressure controlled extract air terminal devices and 40 % for a ventilation system with humidity controlled air terminal devices.

Figure 4.17 illustrates the positioning of the running points corresponding to the maximum and minimum air flow rates. Our comment: this corresponds well to the centralised products used in some countries and refers to some specific building and equipment. The general idea is very interesting.

Table 4-5: Reference total pressures for pressure controlled extract devices (Vialle & al., 2007)

| Air flow rate ranges (m ³ /h) | 0 - 1000 | 1000 - 3000 | 3000 - 8000 | > 8000 |
|---|----------|-------------|-------------|--------|
| Reference total pressure available, P _{t ref} (Pa) | 100 | 150 | 200 | 250 |

Figure 4-17: Running points chosen for a fan unit without control system (Vialle & al., 2007)

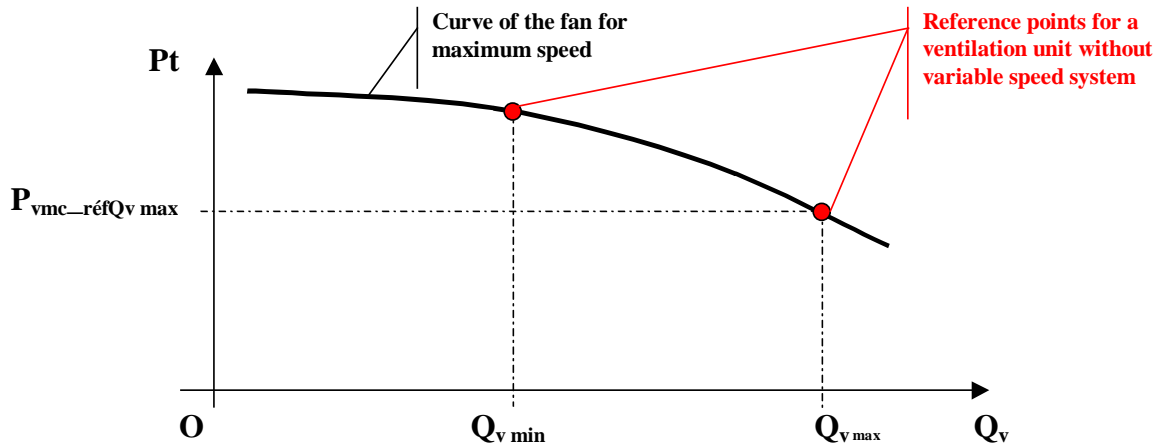

For a fan unit equipped with a constant pressure control device, the running point for the maximum air flow rate is determined in the same way as described here above, but the electrical power taken into account is the one of the running point with the same reference total pressure and an air flow rate equal to 75 % of Q_{v max} the maximum air flow rate defined for ventilation systems without any control device. For this kind of fan unit, the running point for the minimum air flow rate is located at (Q_{v min}, P_{vmc_réfQv_max}) where Q_{v min} represents 50 % of Q_{v max} for a system with pressure controlled terminal devices and 40 % for a system with humidity controlled terminal devices.

Figure 4.18 illustrates the positioning of the running points for the constant pressure fan unit.

Figure 4-18: Running points chosen for a fan unit with constant pressure control system (Vialle & al., 2007)

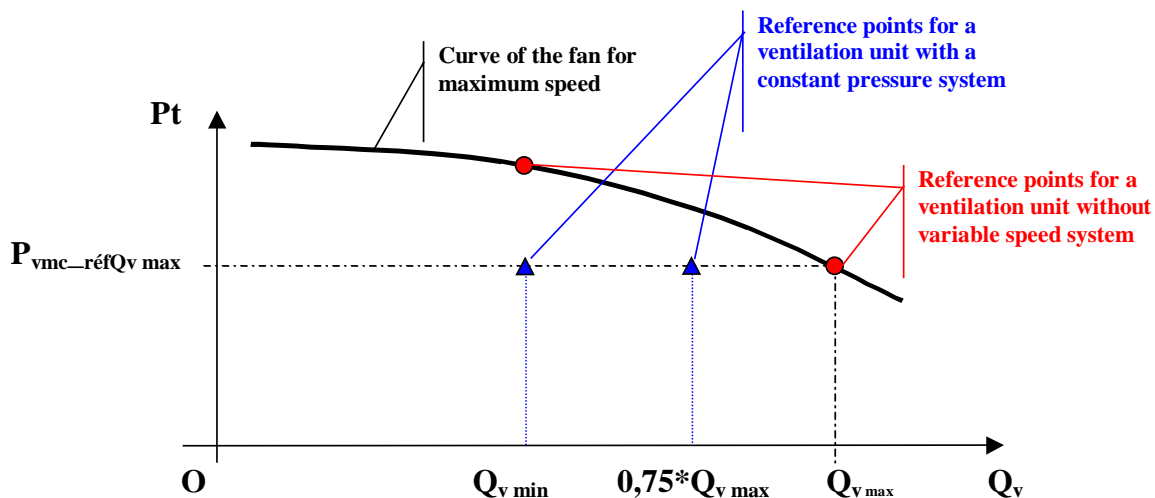

For a fan unit equipped with a constant air flow rate control device, the maximum air flow rate taken into account is always Q_{v max} defined above, but the electrical power retained is the one corresponding

to the running point located at the cross between the fan curve for a constant air flow rate of $0,75 Q_{v \max}$ and the pressure drop curve going through the point $(Q_{v \max}, P_{vmc_réfQ_{v \max}})$. The running point for $Q_{v \min}$ is taken at the cross between the fan curve for $Q_{v \min}$ and the pressure drop curve going through the point $(Q_{v \max}, P_{vmc_réfQ_{v \max}})$. Proportion between $Q_{v \max}$ and $Q_{v \min}$ is the same as defined here above. Figure 4.19 illustrates the positioning of the running points for the constant air flow rate fan unit.

Figure 4-19: Running points chosen for a fan unit with constant air flow rate control system (Vialle & al., 2007)

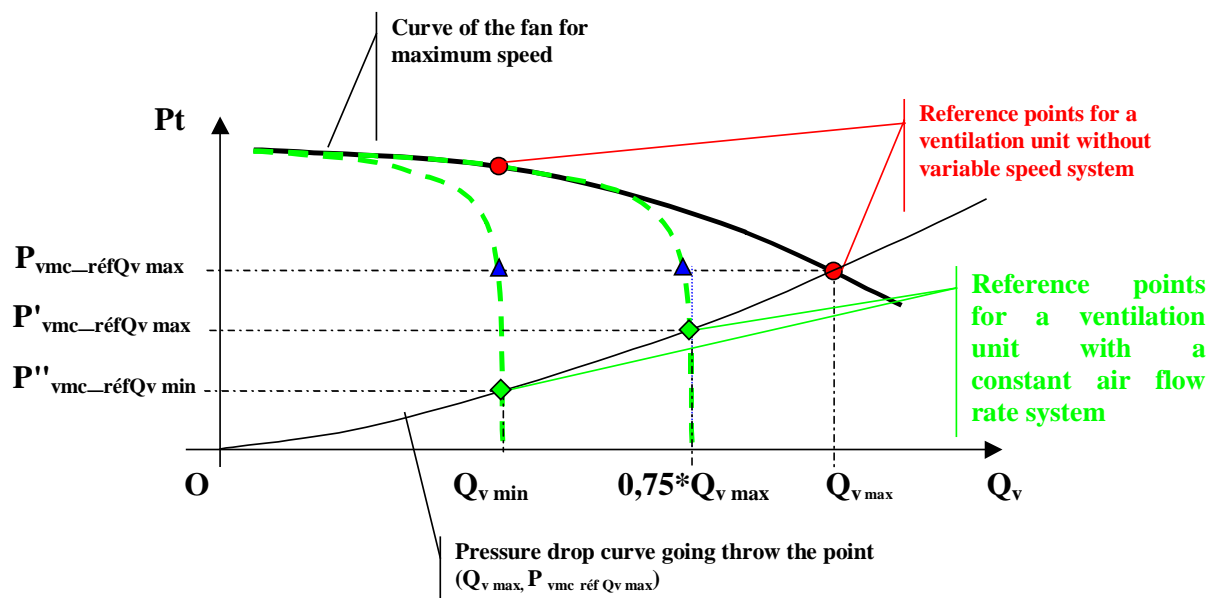

The duration of running at the minimum and maximum speed are defined according the French Building Thermal Regulation. This repartition corresponds to 23/24th of time at the minimum speed (minimum air flow rate) and 1/24th of time at the maximum speed (maximum air flow rate) if the ventilation system includes a device limiting time running at the maximum speed, or 11/12th of time at minimum speed and 1/12th of time at maximum speed without such a device.

The study concludes however that the definitions made are not harmonised within the EU:

The analysis of the results of the enquiry about the use of mechanical ventilation systems in Europe (type of systems, number of speeds and time of running duration for each speed) has shown differences over the different countries. In consequence, the method developed in this study, suitable for the French ventilation systems, is not directly applicable in Europe. The establishment of standard running parameters for Europe is necessary. Especially the reference total pressure for the determination of the running point of multi-family buildings or non residential ventilation fan units needs to be dealt with.

We made an attempt to generalize this approach hereunder in part 4.4.3 in a way avoiding to give common values for pressure demand in MS.

The study by (Vialle & al., 2007) extended the rationale when there is a speed change in the product, not if the operating point moves along the characteristic line.

4.4.2 Feasibility of one single PL (Part Load) index to represent part load gains

Before extending the approach just described we have to define all situations of part load. We have to make the reader aware of the difference between the settings that the manufacturer recommends to the installer to adjust on site once and the manual and automatic controls that will be acting all along the life of the product without further action of the installer. For the settings of the first type the default

settings put in place by the manufacturer on the product will be kept. It may be unfair initially for some manufacturers not aware of their responsibilities, but it will then lead to a better default setting, avoiding misuse by untrained installers.

Logical approach is to start from the most demanding condition (typically full speed) and to characterize the way the product adapts to lower flows. This is an approach that can be made on the data declared by a manufacturer, or by testing. We think also that it is logical to start from the best efficiency point, the indicator being either SFP or Efficiency for that point. What is the efficiency or SFP gain at Part Load?

Part load without strategy

Here we have the case where pressure drop in air transfer devices increases to lower the flow. There may be some gain even if there is no sophisticated control: when we move left from the BEP, hydraulic power, electrical power and efficiency decrease. If we start from another point like a given pressure (100 Pa or other...) it is not certain that efficiency decreases.

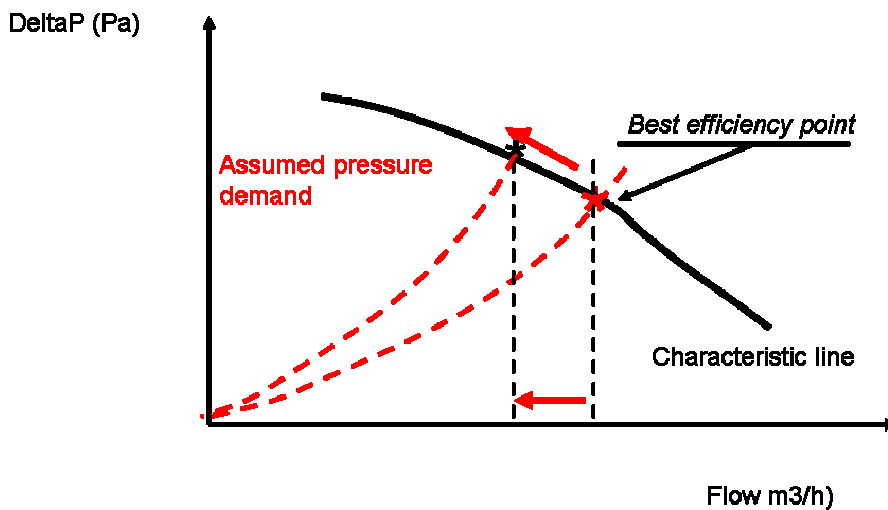

Multi speed strategies

The end user is assumed to select the lowest speed corresponding to the need for flow. The black stars show the operating points, which do not correspond to the BEP for the lower speeds. They can be a given fraction of the flow of the BEP, or a value given from outside.

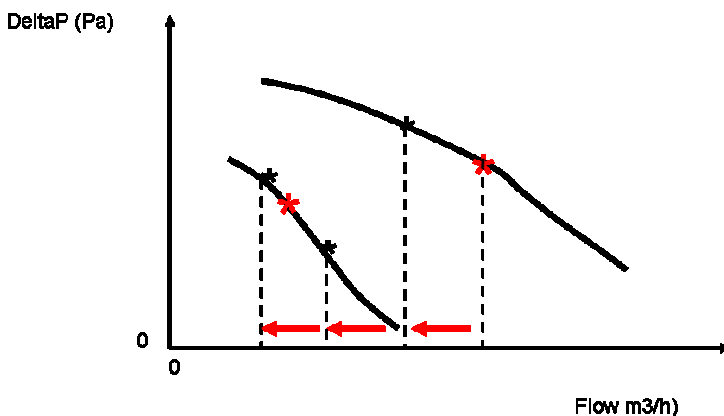

Variable speed strategies

The simplest way of varying automatically the speed is to maintain suction pressure constant. The depression demanded in the circuit cannot increase when the flow decreases; we may assume it remains constant. By varying the speed we obtain a “virtual characteristic line” made of the points with the highest speed allowing to reach the pressure, for the given flow. The fact of starting from the pressure of the BEP in the figure is arbitrary and can be substituted by a given pressure like 100 or 150 Pa in option (A).

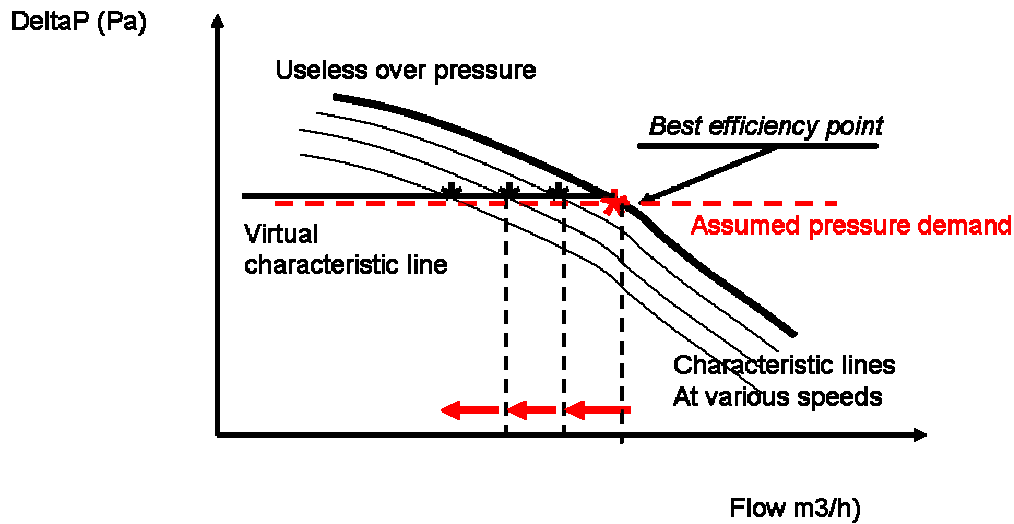

Caution: Not to confuse manual or automatic adjustment made on site by the user or the controller and adjustments that fitter makes once for all.

Ideally the pressure would follow the pressure demand which varies like the square of the flow. A real controller should keep a margin and may look like this:

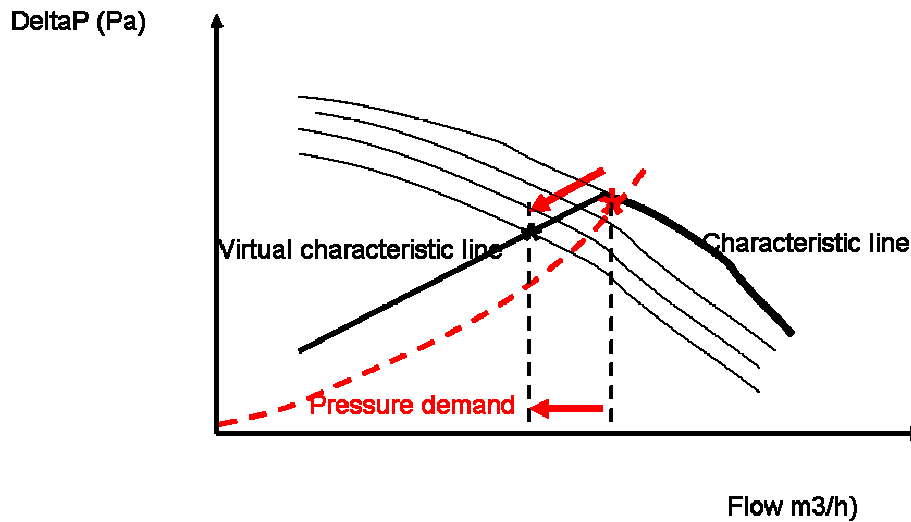

An ideal pressure demand controller would request sensing pressure on every extract; we think it's not available on the market. To define experimentally the efficiency of such a system one should define a reference network for testing. We do not want to enter into the definition of the ventilation network because we want to characterize the product itself. So when the product includes a pressure sensor to be located at some place, we will leave the pressure sensor at the suction of the fan.

Part load testing required

One never asks the question of the operating requirement satisfaction (for example: Sufficient ΔP ?) which remains a national question. **We want to measure consumption with the control of partial load that the equipment can realize. So the controller is on, the sensors are on, with the pre settings made in factory by the manufacturers, not with any specific settings. Standby consumption for sensors and controllers has to be included in the testing process, not treated separately.**

For the small products with Q_{max} (or Q^*) < 50 m³/h one retains only one point, which can be for a certain pressure or the point of maximum output (BEP). This testing is also enough if the manufacturer does not want to see part load control gains taken into account. A default method to estimate EEI at PL from EEI at FL when there is no part load control will be proposed hereunder.

For the largest products, when one wants to take into account their part load control, one imposes four tests at 25 - 50 - 75 - 100 % of maximum flow defined as Q^* (could be Q_{max} or Q at 50 Pa if a benefit was expected from this choice). **The partial flow should be obtained by the natural operation of the control set up in the product or manual selection by the laboratory of the lowest speed giving the right flow. It is not obtained by playing on control variables that are only accessible by the manufacturer or by the installer. All default settings not available daily to the end user are left as tuned in factory.**

We call x_i proportion of the flow during a test (25 - 50 - 75 - 100 %). On each test one measures ΔP_i , Q_i (flow), P_i (electric power demanded). ΔP_i cannot too small, and should be higher than $\Delta P^* x_i^2$ (square law of head losses).

The points are published to be able to be used for national weightings, and not only the result of the calculation that we will propose now. We can use a European weighting of all four tests in product regulation as here, but we can also imagine that some countries want to weigh the same points in a different manner inside their building codes.

4.4.3 Definition of scenarios for EEI_{PL} (Energy Efficiency Index at part Load)

Our EEI_{PL} should have the following features: to give back the selected EEI_{FL} when there is no load adaptation; to ease yearly calculation of electrical consumption; to give a reward to the innovative strategies and to treat with equity all MS solutions. Frequency of flow rates under the full load value in an EU residential ventilation system are estimated as follows:

Table 4-6: Possible of part load flow rates and frequency

| | | | | |
|--|--------|--------|--------|--------|
| Part load value in % of maximum flow x_i | 100% | 75% | 50% | 25% |
| Frequency of this situation F_i | 10,00% | 20,00% | 30,00% | 40,00% |

Certification of the published points by an independent European institution like Eurovent-Certification or IMQ or one of the national bodies mentioned in part 1 would be a good thing.

An immediate expression is the one of the yearly weighted electrical power, lower in general than nominal power :

$$P_{elec\ average} = \sum F_i P_i$$

This average power is not suitable for use as a basis for product regulation because it has a meaning for a certain size of building, of flow, etc. but the MS can compute it in their building codes from the four testing points suggested for product characterization.

We have outlined the following scenarios for product characterisation :

Scenario 1 SFP at 0, 100, 150, 200 Pa extended for PL

The flows used for testing would be logically a fraction of the flow at the reference pressure (for instance $Q(100Pa)$). For each point the laboratory reports Pelec, flow, $SFP = Pelec/flow$
The indicator is the weighted SFP_w (not resulting from weighting the SFPs but from doing the same calculation with weighted Pelec and flow):

$$SFP_w = \Sigma F_i P_i / \Sigma F_i Q_i$$

We can compare the fans by their SFP_w within the same class of nominal pressure ΔP_{max} . In order to get an information very clear it could be necessary that the ΔP remains in the same class at partial load.

Scenario 2 Efficiency at 0, 100, 150, 200 Pa extended for PL

The testing conditions being the same, only the computation is different:

$$Eff._w = \Sigma F_i Q_i \Delta P_i / \Sigma F_i P_i$$

In order to get an information very clear it could be necessary that the ΔP remains in the same class at partial load.

Scenario 3 SFP at BEP extended for PL

Q_i tests are defined as fractions of Q^* . Same as scenario 1 but based on reference flow at BEP not maximal flow

$$SFP_w = \Sigma F_i P_i / \Sigma F_i Q_i$$

Scenario 4 Efficiency at BEP extended for PL

Q_i tests are defined as fractions of Q^* . For each point the laboratory reports Pelec, flow, ΔP , $Phydro = flow * \Delta P$, and the average efficiency is then the same :

$$Efficiency = \Sigma F_i Q_i \Delta P_i / \Sigma F_i P_i$$

Discussion

The analysis shows that scenarios 2&4 capture the average efficiency but not the lower $Phydro$ demand. Scenarios 1& 2 suffer from the fact of indicating a preference pressure that may well not be respected at part load. Scenario 3 gives an SFP having nothing arbitrary (reference pressure and flows are “decided” by the manufacturer at design time). However we can only compare products within a class with similar pressure levels. Our final PL proposal will be to express this SFP_w as an efficiency under the following expression :

Scenario 5 An index with the benefits of SFP_w but expressed as an efficiency

Q_i tests are defined as fractions of Q^* . In order to have an EEI not express in % we multiply by 100 :

$$EEI (PL) = \Delta P^* / SFP_w \times 100$$

That can be written as

$$EEI (PL) = \Sigma F_i x_i Q^* \Delta P^* / \Sigma F_i P_i$$

EI (PL) is equal to EI (FL) for the products with constant ΔP and constant electromechanical efficiency. It is lower than EI (FL) when there is no control (and a valve will be installed to lower flow on site) and higher when the pressure decreases at part load. The largest change that can happen is an EI (PL) which is 50 % of the EI (FL)¹². This remark will be used in chapter 8.

4.4.4 One worked out example

In order to give one example we consider the two speeds ICV for which the manufacturers directory gives the following graph. It's the product already considered in 4.3.5 with its two speeds (upper and lower line) and a manual switch to request high speed. There is no automatic setback from high speed, so high speed is high speed, not a booster. High speed demands 73.1 W input while lower speed demands 27.4 W input.

Figure 4-20: Typical ICV characteristic line and progression of testing to obtain EI PL

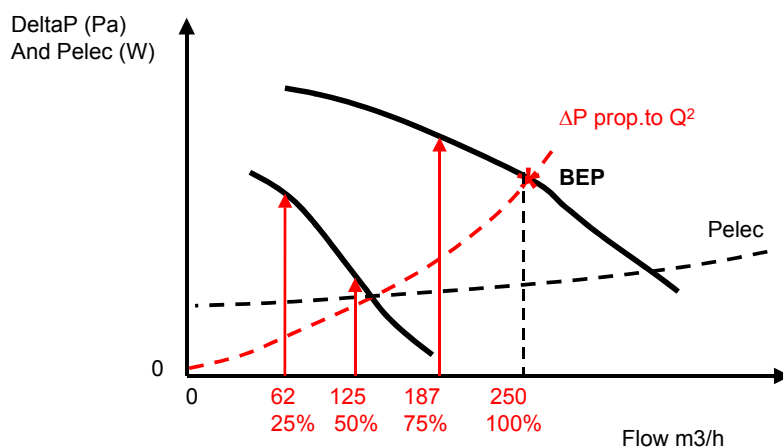

Table 4.4 shows the calculation based on figure 4.15. Since speed variation is not continuous and there is no automatic timer bringing speed down from the highest speed, we have to determine first the BEP of high speed. Here it's for $Q^*=250$ m³/h, also called Q₄. The reduced flow Q₃ can only be attained with the high speed with a pressure corresponding to the BEP through the square law, while Q₂ can be attained with the low speed at a reasonable pressure, and Q₄ as well.

Table 4-7: Progression of testing at part load

| Steps | xi (flow reduction factor) | Fi (frequency of occurrence) | Flow rate m ³ /h | ΔP in Pascal at high speed | Minimum DeltaP in Pascal | DeltaP in Pascal at low speed | Pi (input) including sensors & standby |
|---|----------------------------|------------------------------|-----------------------------|------------------------------------|--------------------------|-------------------------------|--|
| Step 1 BEP high speed (Q*, ΔP^*) | 1 | 0,1 | 250 | 270 | - | - | 73,10 |
| Step 2 : 75% flow | 0,75 | 0,2 | 187,5 | 300 | 151,875 | - | 73.00 |
| Step 3 : 50% flow | 0,5 | 0,3 | 125 | - | 67,5 | 100 | 27,5 |
| Step 4 : 25% flow | 0,25 | 0,4 | 62,5 | - | 16,875 | 230 | 27,4 |

The following calculation leads to the determination of the EI PL.

¹² This can be demonstrated by assuming P_i constant equal to value at BEP

$$\Sigma F_i x_i Q^* \Delta P^* = 9.375 \text{ W}$$

$$\Sigma F_i P_i = 41.11 \text{ W}$$

$$EEI (PL) = \Sigma F_i x_i Q^* \Delta P^* / \Sigma F_i P_i = 23 \text{ (22.80\% rounded up because it's over 22.50\%)}$$

By neglecting the control options we would estimate EEI (FL) = 26 (25.75% rounded up for the same reason)

In this case despite of the two speeds, the figure at part load is not better than at full load.

4.4.5 Some average results

In order to perform the energy calculation, we have extracted from our data basis the necessary quantities.

Table 4-8: Computation of options A – scenario 1 (SFP at given conditions) and B –scenario 4 (Efficiency at BEP) for some products in our data base

| Product type | Range of max DeltaP (Pa) | Range of max flow (m3/h) | Nominal power demand (W) | Averaged SFP at 100 Pa | Averaged EEI FL | Averaged EEI PL | Average Pelec (W) over speeds |
|----------------------------|--------------------------|--------------------------|--|----------------------------------|----------------------------|----------------------------------|-------------------------------|
| DV/roof | 50 to 400 | 1000 to 10000 | 90 W (90 to 1400) | n.a. (for the 90W) ¹³ | 16 (for the 90W) | 8 (for the 90W) | 90 |
| DV/window or wall or attic | up to 120 | 70 to 600 | 13 to 125 (17 for axial; 58 for cent.) | n.a. ¹⁴ | 3 for axial (12 for cent.) | 2 for axial (up to 20 for cent.) | 17 for axial |
| DV/hoods | 300 | 250 | 100 to 200 (150) | 0.40 ¹⁵ | 9 | >6 | 90 |
| ICV | 100 to 160 | 250 to 430 | 28 to 83 (75) | 0.13 to 0.23 | 19 | 12 | 40 |
| CCV | 120 to 160 | 400 to 6000 | 95 to 600 | 0.20 to 0.26 | 16 | n.a. | n.a. |
| HCV | 17 | 400 | 16 | n.a. | 12 | 6 | n.a. |
| ICV&HR | 350 | 300 | 136 (2 flows) | 0.23 | 15 | na | n.a. |

One should immediately remark that in the categories with sufficient information, and whatever the indicator is, there is a factor 3-5 in performance between the best and the worst performer.

As already discussed it's sometimes impossible to compute the SFP at 100 Pa for some products. About the distributed ventilation products, we didn't see any significant difference between wall and window fan. About the roof fans we discovered in the data basis that they are not at all suitable for residential use, when we see the magnitude of flow rates, which would lead to 2 or 3 ACH in a dwelling. Most of them will not be in the scope of the residential study, except specific collective applications. We have not found any product integrating heat recovery and double flow ventilation for collective buildings. The parts should be purchased separately and/or designed specifically for the project.

¹³ SFP at 0 Pa being 0.09 so all are compliant with the US Energy Star rating of 0.21

¹⁴ SFP at 0 Pa being 0.10 so all are compliant with the US Energy Star rating of 0.21

¹⁵ SFP at 0 Pa being 0.24 so not all compliant with the US Energy Star rating of 0.21

Average components efficiencies and technical trends

The substitution of AC motors by DC motors, with a better efficiency and more lifetime, is not yet important on the EU market, taken as a whole. The most frequent ICV is a centrifugal fan (flat blades) directly coupled to an AC induction electric motor, also defined as asynchronous with a permanent condenser. The efficiency of the motor can be as low as 20 or 50 %, and the one of the air moving part is limited to 20 to 50 % according to some stakeholders. This explains the values found in the market study. There are no spontaneous trends of diffusion of the best efficiency products.

Range hoods and remote controlled products in general display a low power mode. At the moment only data for residential range hood are available thanks to www.energyrating.gov.au. There is no other data available for standby despite some manufacturers propose remote control capabilities. The share of products with remote control capabilities is not known. Most units have a hard off switch. In addition, the off mode is generally below 0,1 W except for 3 units among 54. Information on Australian standby product profile of range hoods gives the following requirements for off mode.

1. INTERIM TARGET - 2008

Off mode (W)

Less than 0.5 Watt

This target applies to all relevant rangehoods sold in Australia that year. NAEDEC proposes to monitor the sale of rangehoods in that year and to move toward regulation should that target not be met by a significant number of products.

2. NATIONAL STANDBY STRATEGY TARGET – 2012

Off mode (W)

Less than 0.3

The National Standby Strategy sets out the target of 0.3W, to be achieved by 2012. This target should apply to all rangehoods.

This seems consistent with the indications we have from lot 6.

4.5 End-of-life phase

From the declarations of the stakeholders we concluded that all products end up in general disposal presently.

Task 4 summary

The use of the Ventilation product determines its features which fall into one of the categories:

- DV Decentralised
- ICV Individual Centralised
- CCV Collective Centralised
- HCV Hybrid Collective Ventilation
- DV&HR as DV but with heat recovery (doubles at least electrical consumption)
- ICV&HR as ICV but with heat recovery (doubles at least electrical consumption)
- CCV&HR as CCV but with heat recovery (doubles at least electrical consumption)

Each product has an infinity of possible operating points along a line called characteristic line in the plan (pressure, flow). The characteristic lines have been modified by generations of engineers and may have various aspects named here from (a) to (f).

This variety of operating conditions possible with each product can be reduced either to one point in specified conditions (for instance 100 Pa), or to the optimal point assuming that this optimal point has been carefully chosen by the manufacturers. The second solution seems more favourable, because it does not collide with the national building codes but has to be accepted. For either one of the points there is a choice to indicate efficiency itself or SFP at that point.

The authors propose an extension of the SFP or of the efficiency to take into account improvements taking place at part load. Both SFP_w and EEI_{PL} are indices ready for use but not commonly used yet.

Technical and energy characteristics of main products found in directories are given, including Bills of Materials. It is to be noted that roof fans found on the EU market do not correspond to residential air flow rates. Collective ventilation products are not fully studied but are investigated in lot 11. HCV can be fully integrated among ICV in the following.

Independently from the size effects, whatever the indicator is, there is a factor 3-5 in performance between the best and the worst performer.

5 DEFINITION OF AVERAGE BASE-CASE

5.1 Product-specific inputs

Avg. EU product weight and Bill-of-Materials, distinguishing materials fractions (weight) at the level of the EuP EcoReport Unit Indicators as proposed in the MEEUP report. This includes packaging materials;

- *Primary scrap production during sheet metal manufacturing (avg. EU);*
- *Volume and weight of the packaged product avg. EU;*
- *Annual resources consumption (energy, water, detergent) and direct emissions during product life according*
- *to the test standards defined in subtask 1.2 [“EU Standard Base-Case”];*
- *Annual resources consumption (energy, water, detergent) and direct emissions during product life according to the real-life situation as defined in subtask 3.2 [“EU Real-life Base-Case”];*
- *Selected EU scenario at end-of-life of materials flow for:*
- *Disposal (landfill, pyrolytic incineration);*
- *Thermal Recycling (non-hazardous incineration optimised for energy recovery);*
- *Re-use or Closed-loop Recycling.*

In order to define the base case we used our data base of models being presently sold in EU 27. Table 5.1 gives the energy aspect and the weight. By applying the ratios of previous part, one can compute the rest of environmental impacts.

Computation of electricity consumption of the product in the system

In the case of individual dwellings (and collective dwellings when ventilated in a decentralised manner), where we know the number of DV and ICV in use or being purchased (and the size of each product) we recommend to base the computation on this knowledge:

Yearly consumption of one product used in one dwelling = average power demand (including the effect of existence of multi speeds and other controls when relevant) 8760 hours (or less if ON/OFF¹⁶)*

In the case of collective dwellings, we have estimated the number of CCV in use or being purchased (and the size of each product) but the product is adjusted by a fitter to the size of the buildings so we recommend to base the computation on the knowledge of ventilated area:

Yearly consumption of one product used for various dwellings = volume ventilated ACH* DeltaP / EEI* 8760 hours*

Where

- Volume ventilated = area ventilated (the one of task 2)* 2,50 m3/m2
- ACH: number of air change rates, typically 1, may vary according to countries in further work
- DeltaP: here 100 Pa= typical depression generated, may be substituted by pressure difference at optimal efficiency point.
- EEI: average efficiency of the motor/fan (the product).

Energy use by products in use in 2005

¹⁶ Typically hoods and intermittent DV are used two hours a day

We obtained the unitary values for DV and ICV:

Table 5-1: Average energy consumption by product (DV & ICV)

| Product type | Average power demand (W/unit) over speeds | Yearly Energy Consumption (kWh/unit) | Mass (grams) |
|----------------------------|---|--------------------------------------|--------------|
| DV/window continuous | 17 | 148,92 | 986 |
| DV/wall continuous | 17 | 148,92 | 986 |
| DV/window intermittent | 17 | 12,41 | 986 |
| DV/wall intermittent | 17 | 12,41 | 986 |
| DV/hood intermittent | 90 | 65,70 | 10440 |
| ICV continuous 2 speeds | 40 | 350,40 | 4640 |
| DV&HR continuous | 30 | 262,80 | 3480 |
| ICV&HR continuous 2 speeds | 66 | 578,16 | 7656 |

For CCV, the calculation is by square meter not by unit. Provisional value is 2.5 (volume ventilated per sq.m)* 1 ACH¹⁷* 150 (DeltaP¹⁸) / 0.16 (average EEI)* 8760 hours, i.e.

Table 5-2: Average energy consumption by product (CCV)

| Product type | Average power demand (W/sq.m) over speeds | Yearly Energy Consumption (kWh/sq.m) | Mass (grams/sq. m.) |
|--------------|---|--------------------------------------|---------------------|
| CCV | 0,65 | 5,70 | 76 |
| CCV&HR | 1,30 | 11,41 | 151 |

Appreciation of the fields of uncertainty on energy consumption

For all intermittent DV (either hoods or not) the duration of use is largely uncertain. In the case of heat recovery, there is not only a larger pressure drop to balance (more than double, because of the two sides of the heat exchanger and of the Colburn Reynolds analogy) but also the influence of the filters. Those filters are the main consumable of the product and a source of additional energy consumption.

Material input

The average weight of ventilation products has been calculated to 116 grams per W in task 4 ; this value is used here for all categories except window and wall fans, that, with more plastic, have a lower mass / power ratio (values in red).

Material inputs for the different base cases have been presented in task 4.1.

A summary of inputs required is summarized in the following table.

¹⁷ ACH= 1 in m3/h but 1/3600 in SI units

¹⁸ 300 Pa in case of HR

Table 5-3: Summary of input for the environmental impact analysis

| Products | | | | | | | | |
|---------------------------------|---------------------------|-----------------------------|------------------|----------------------|-------------------------|----------------------------|---------|---------|
| Characteristics | DV/window&wall continuous | DV/window&wall intermittent | DV&HR continuous | DV/hood intermittent | ICV continuous 2 speeds | ICV&HR continuous 2 speeds | CCV | CCV&HR |
| General characteristics | | | | | | | | |
| Power demand (W) | 17,0 | 17,0 | 30,0 | 90,0 | 40,0 | 66,0 | 264,8 | 529,6 |
| Energy consumption (kWh) | 148,9 | 12,4 | 262,8 | 66,0 | 350,4 | 578,2 | 2322,3 | 4648,7 |
| Volume packaged (L) | 2,0 | 2,0 | 3,5 | 20,9 | 9,3 | 23,0 | 77,4 | 123,0 |
| Mass (g) | 986,0 | 986,0 | 3480,0 | 10440,0 | 4640,0 | 7656,0 | 30964,0 | 61520,6 |
| Composition | | | | | | | | |
| Aluminium | 0% | 0% | 1% | 0% | 24% | 24% | 33% | 36% |
| Steel | 46% | 46% | 38% | 80% | 29% | 40% | 53% | 49% |
| Electronics | 1% | 1% | 0% | 1% | 2% | 2% | 2% | 2% |
| Iron | 0% | 0% | 2% | 0% | 0% | 0% | 5% | 5% |
| Bulk Plastics | 32% | 32% | 52% | 10% | 25% | 14% | 0% | 0% |
| Tech.Plastics | 18% | 18% | 3% | 9% | 6% | 6% | 0% | 0% |
| Copper | 2% | 2% | 4% | 2% | 6% | 6% | 6% | 7% |
| Brass | 0% | 0% | 1% | 0% | 0% | 0% | 0% | 0% |
| Others | 0% | 0% | 0% | 0% | 8% | 8% | 1% | 1% |
| Total | 100% | 100% | 100% | 100% | 100% | 100% | 100% | 100% |

5.2 Base-Case Environmental Impact Assessment

Using the VHK EuP EcoReport indicate the environmental impact analysis, specifying: Emission/resources categories as mentioned in the MEEUP Report for:

- Raw Materials Use and Manufacturing;*
- Distribution;*
- Use;*
- and End-of-Life Phase.*

and distinguishing for the Use phase between the Standard Base-Case and the Real-life Base-Case. Furthermore, if more than one type of resource is used in the Use phase, make a split-up between resources and their individual impacts.

Primary scrap production during sheet metal manufacturing (avg. EU) is kept at the default value of 25 %. Concerning reuse and recycling default values are kept.

Table 5-4: Summary of the environmental impacts of base cases, total environmental impact and energy use

| Environmental impacts of base cases | | DV cont | DV interm | DV&HR | DV hood | ICV | ICV&HR | CCV | CCV&HR |
|---------------------------------------|-------------|-----------|-----------|-----------|-----------|-----------|-------------|-------------|---------------|
| | | TOT USE | TOT USE | TOT USE | TOT USE | TOT USE | TOT USE | TOT USE | TOT USE |
| Materials | | | | | | | | | |
| Disposal | kg | 0,45 | 0,45 | 1,78 | 2,32 | 1,54 | 1,83 | 2,14 | 4,24 |
| Recycl. | kg | 0,54 | 0,54 | 1,68 | 8,33 | 3,10 | 5,83 | 28,83 | 57,28 |
| Total | kg | 1,00 | 1,00 | 3,46 | 10,65 | 4,64 | 7,66 | 30,96 | 61,52 |
| Other Resources & Waste | | | | | | | | | |
| Total Energy (GER) | MJ | 15,8 15,6 | 1,5 1,3 | 37,2 36,8 | 7,5 6,9 | 50,0 36,8 | 92,8 60,7 | 352,4 243,9 | 662,2 488,2 |
| of which, electricity (in primary MJ) | MJ | 15,7 15,6 | 1,3 1,3 | 36,9 36,8 | 7,1 6,9 | 36,9 36,8 | 60,9 60,7 | 244,4 243,8 | 489,1 488,1 |
| Water (process) | ltr | 1,1 1,0 | 0,1 0,1 | 2,5 2,5 | 0,5 0,5 | 2,5 2,5 | 4,0 4,0 | 16,3 16,3 | 32,6 32,5 |
| Water (cooling) | ltr | 41,8 41,7 | 3,5 3,5 | 98,4 98,1 | 18,5 18,5 | 98,1 98,1 | 161,9 161,9 | 650,4 650,2 | 1301,9 1301,6 |
| Waste, non-haz./ landfill | g | 20,9 18,2 | 4,3 1,5 | 48,4 42,7 | 20,2 8,1 | 61,9 42,8 | 108,5 70,6 | 444,9 283,8 | 883,4 568,2 |
| Waste, hazardous/ incinerated | g | 0,8 0,4 | 0,5 0,0 | 2,6 0,8 | 2,0 0,2 | 2,3 0,8 | 3,1 1,4 | 6,6 5,6 | 12,9 11,2 |
| Emissions (Air) | | | | | | | | | |
| Greenhouse Gases in GWP100 | t CO2 eq. | 0,7 0,7 | 0,1 0,1 | 1,6 1,6 | 0,3 0,3 | 2,4 1,6 | 4,5 2,6 | 17,0 10,6 | 31,6 21,3 |
| Ozone Depletion, emissions | mg R-11 eq. | neg. neg. | neg. neg. | neg. Neg. | neg. neg. | neg. neg. | neg. neg. | neg. neg. | neg. neg. |
| Acidification, emissions | t SO2 eq. | 4,1 4,0 | 0,4 0,3 | 9,6 9,5 | 2,0 1,8 | 12,0 9,5 | 21,7 15,6 | 83,5 62,8 | 159,4 125,7 |
| Volatile Organic Compounds (VOC) | kg | 0,0 0,0 | 0,0 0,0 | 0,0 0,0 | 0,0 0,0 | 0,2 0,0 | 0,5 0,0 | 1,7 0,1 | 2,8 0,2 |
| Persistent Organic Pollutants (POP) | mg i-Teq | 0,1 0,1 | 0,0 0,0 | 0,3 0,2 | 0,2 0,0 | 0,3 0,2 | 0,6 0,4 | 2,5 1,6 | 4,8 3,2 |
| Heavy Metals | g Ni eq. | 0,3 0,3 | 0,1 0,0 | 0,7 0,6 | 0,2 0,1 | 1,0 0,6 | 1,9 1,0 | 7,2 4,2 | 13,3 8,4 |
| PAHs | g Ni eq. | 0,0 0,0 | 0,0 0,0 | 0,1 0,1 | 0,0 0,0 | 0,6 0,1 | 1,3 0,1 | 4,9 0,5 | 8,6 1,0 |
| Particulate Matter (PM, dust) | kg | 0,1 0,1 | 0,1 0,0 | 0,4 0,2 | 0,3 0,0 | 32,2 0,2 | 79,2 0,3 | 266,4 1,3 | 424,1 2,7 |
| Emissions (Water) | | | | | | | | | |
| Heavy Metals | g Hg/20 | 0,1 0,1 | 0,0 0,0 | 0,3 0,2 | 0,1 0,0 | 0,3 0,2 | 0,5 0,4 | 2,1 1,6 | 4,2 3,2 |
| Eutrophication | g PO4 | 1 0 | 1 0 | 3 1 | 2 0 | 2 1 | 3 2 | 11 8 | 21 15 |
| Persistent Organic Pollutants (POP) | ng i-Teq | neg. neg. | neg. neg. | neg. Neg. | neg. neg. | neg. neg. | neg. neg. | neg. neg. | neg. neg. |

5.3 Base-Case Life Cycle Costs

Combining the results from tasks 2 and 3 define — for the Standard and Real-Life Base-Case the Life Cycle Costs

Electricity average price is 0.158 euro / kWh and discount rate equals 2 % (more information can be found in the air conditioner study). Other LCC hypothesis are reported in the table below.

Table 5-5: LCC of base cases

| LCC base cases | DV cont | DV interm | DV&HR | DV hood | ICV | ICV&HR | CCV | CCV&HR |
|--|------------|-------------|--------------|-------------|-------------|-------------|-------------|--------------|
| General characteristics | | | | | | | | |
| Power W | 17,0 | 17,0 | 30,0 | 90,0 | 40,0 | 66,0 | 264,8 | 529,6 |
| Elec. kWh | 148,9 | 12,4 | 262,8 | 66,0 | 350,4 | 578,2 | 2322,3 | 4648,7 |
| LCC input (euros) | | | | | | | | |
| Price | 30,0 | 30 | 700 | 400 | 250 | 2 000 | 800 | 2 500 |
| Installation | - | - | - | 250 | 250 | 250 | 500 | 500 |
| Maint. 4% | - | - | 280 | 260 | 200 | 900 | 520 | 1 200 |
| LCC unit (euros) | | | | | | | | |
| Product price | 30,0 | 30,0 | 700,0 | 400,0 | 250,0 | 2000,0 | 800,0 | 2500,0 |
| Installation costs | 0,0 | 0,0 | 250,0 | 250,0 | 250,0 | 250,0 | 500,0 | 500,0 |
| Electricity | 211,3 | 17,6 | 497,3 | 93,7 | 497,3 | 820,6 | 3295,9 | 6597,7 |
| Rep & maint. | 0,0 | 0,0 | 251,5 | 0,0 | 179,7 | 808,4 | 467,1 | 1077,9 |
| TOTAL | 241,3 | 47,6 | 1698,8 | 743,7 | 1177,0 | 3879,0 | 5063,0 | 10675,6 |
| Elec / total ratio | 88% | 37% | 29% | 13% | 42% | 21% | 65% | 62% |
| LCC of new products installed in 2005 (Meuros) | | | | | | | | |
| Number of products (M) | 0,3 | 4,4 | 0,014 | 3,9 | 1,3 | 0,1 | 0,7 | 0,0 |
| Product price | 9,5 | 133,2 | 9,8 | 1553,2 | 327,5 | 208,0 | 538,4 | 10,0 |
| Installation costs | 0,0 | 0,0 | 3,5 | 970,8 | 327,5 | 26,0 | 336,5 | 2,0 |
| Electricity | 67,0 | 78,1 | 7,0 | 363,7 | 651,5 | 85,3 | 2218,2 | 26,4 |
| Rep & maint. | 0,0 | 0,0 | 3,5 | 0,0 | 235,3 | 84,1 | 314,4 | 4,3 |
| TOTAL | 76,5 | 211,3 | 23,8 | 2887,7 | 1541,8 | 403,4 | 3407,4 | 42,7 |
| Elec / total ratio | 88% | 37% | 29% | 13% | 42% | 21% | 65% | 62% |
| Annual expenditure of all products in 2005 (Meuros) | | | | | | | | |
| Number of products (M) | 2,1 | 29,6 | 0,084 | 36,2 | 11,0 | 0,62 | 6,16 | 0,025 |
| Product price | 9,5 | 133,2 | 9,8 | 1553,2 | 327,5 | 208,0 | 538,4 | 10,0 |
| Installation costs | 0,0 | 0,0 | 3,5 | 970,8 | 327,5 | 26,0 | 336,5 | 2,0 |
| Electricity | 49,7 | 57,9 | 4,7 | 377,7 | 608,4 | 56,7 | 2260,6 | 18,4 |
| Rep & maint. | 0,0 | 0,0 | 2,4 | 0,0 | 219,8 | 55,9 | 320,4 | 3,0 |
| TOTAL | 59,2 | 191,1 | 20,3 | 2901,6 | 1483,2 | 346,6 | 3455,9 | 33,4 |

The electricity consumption represents from 13 % of the life cycle cost for the end-user for hoods, up to 88 % for Window and wall fans used continuously. The total income of the ventilation manufacturing industries would be in the range of 3 billion Euros. With an almost equal comfort level but a likely higher thermal consumption the use of two or three DV in one dwelling would cost as much as an ICV.

5.4 EU Totals

Aggregate the Real-Life Base-Case environmental impact data (subtask 5.2) and the Life Cycle Cost data (subtask 5.3) to EU-25 level, using stock and market data from task 2, indicating the life cycle environmental impact and total LCC of the new products designed in 2005 (this relates to a period of 2005 up to 2005+product life); the annual (2005) impact of production, use and (estimated) disposal of the product group, assuming post-RoHS and post-WEEE conditions.

5.4.1 Impact and LCC of new products installed in 2005

The total weight of products installed in 2005 is about 75 kt. Materials and their end of life fate is shown in the figure below.

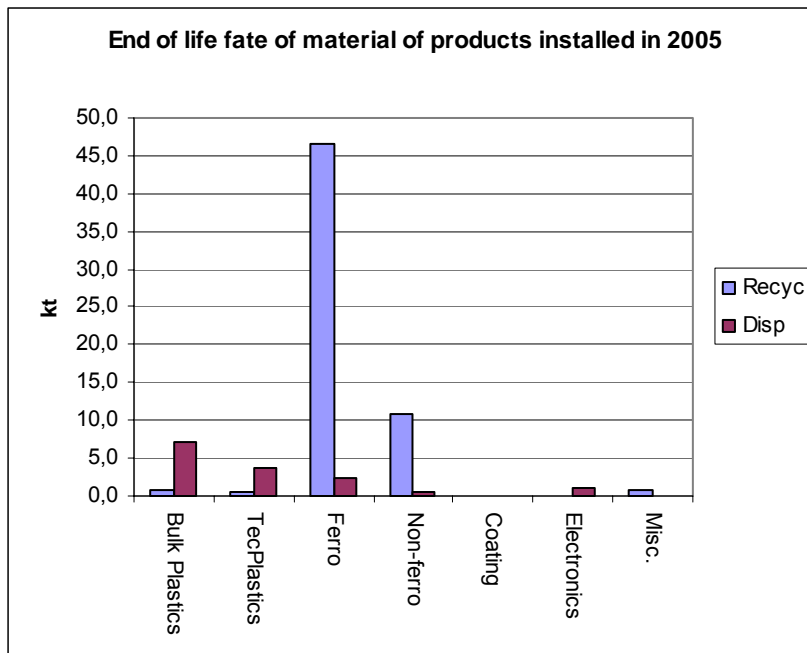

Figure 5-1: End of life fate of material of residential ventilation products installed in 2005

Concerning other resources and waste, the energy consumption is the major contributor. 73% of Total Energy use, 100% of electricity use, 98% of Water (process) rejection, 100% of Water (cooling) rejection, 60% of Waste, non-hazardous going to a landfill and 34% of Waste, hazardous to be incinerated are generated in the use phase, in relation with energy consumption.

| | Material | Manuf. | Distribution | Use | EoL | TOTAL |
|--|----------|--------|--------------|-------|------|-------|
| Total Energy (GER),PJ | 3,7 | 0,9 | 91,8 | 258,8 | 0,8 | 356,1 |
| of which, electricity (in primary PJ) | 0,5 | 0,5 | 0,2 | 258,7 | 0,0 | 260,0 |
| Water (process), mln. m3 | 0,4 | 0,0 | 0,0 | 17,3 | 0,0 | 17,6 |
| Water (cooling), mln. m3 | 0,4 | 0,2 | 0,0 | 690,0 | 0,0 | 690,6 |
| Waste, non-haz./ landfill, kt | 145,7 | 3,8 | 44,5 | 301,5 | 4,5 | 500,0 |
| Waste, hazardous/ incinerated, kt | 0,3 | 0,0 | 0,9 | 6,0 | 10,7 | 17,9 |

Table 5-6: Environmental impact of residential ventilation products installed in 2005, energy, water and waste

Over their lifetime, all residential ventilation products sold in 2005 will consume 25.5 TWh between 2005 and 2015.

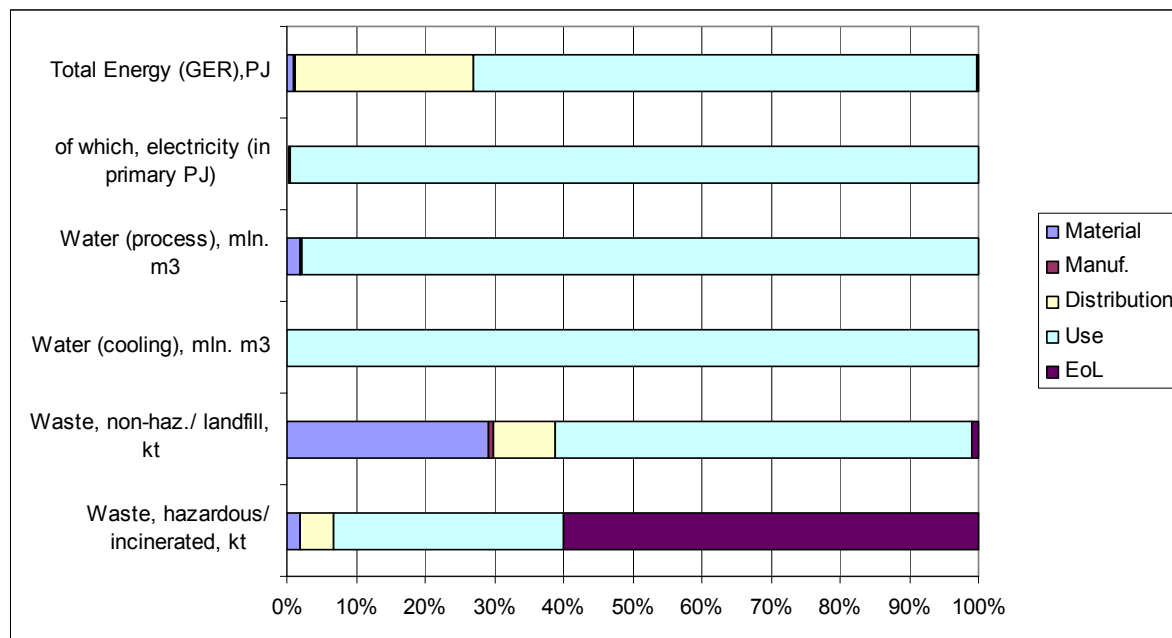

Figure 5-2: Environmental impact of residential ventilation products installed in 2005, energy, water and waste

| | Material | Manuf. | Distribution | Use | EoL | TOTAL |
|---|----------|--------|--------------|------|-----|-------|
| Greenhouse Gases in GWP100 (Mt CO2 eq) | 0,2 | 0,1 | 5,4 | 11,3 | 0,1 | 17,1 |
| Acidification, emissions, kt SO2 eq. | 1,9 | 0,2 | 16,7 | 66,6 | 0,1 | 85,7 |
| Volatile Organic Compounds (VOC), kt | 0,0 | 0,0 | 1,4 | 0,1 | 0,0 | 1,5 |
| Persistent Organic Pollutants (POP), g i-Teq | 0,9 | 0,1 | 0,3 | 1,7 | 0,0 | 2,9 |
| Heavy Metals, ton Ni eq. | 0,4 | 0,2 | 2,3 | 4,4 | 0,3 | 7,6 |
| PAHs, ton Ni eq. | 0,9 | 0,0 | 3,0 | 0,5 | 0,0 | 4,4 |
| Particulate Matter (PM, dust) | 0,3 | 0,0 | 229,9 | 1,4 | 1,3 | 232,9 |

Table 5-7: Environmental impact of residential ventilation products installed in 2005, emissions to air

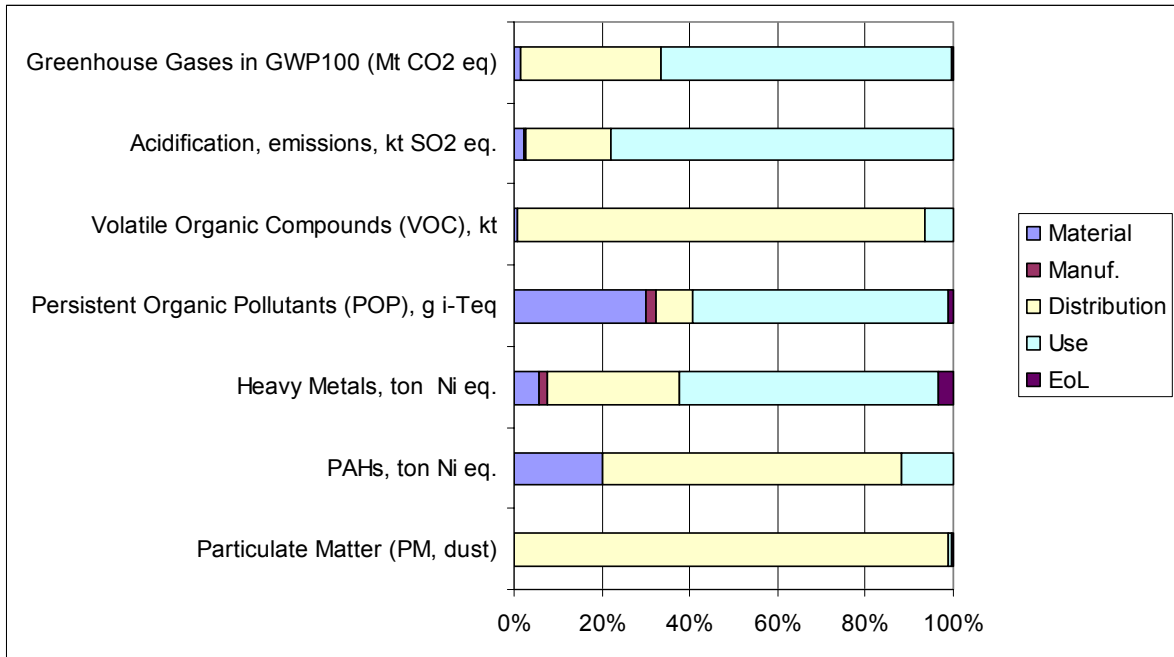

Figure 5-3: Environmental impact of residential ventilation products installed in 2005, emissions to air

| | Material | Manuf. | Distribution | Use | EoL | TOTAL |
|--------------------------------|----------|--------|--------------|--------|--------|--------|
| Heavy Metals, ton Hg/20 | 0,7 | 0,0 | 0,1 | 1,7 | 0,1 | 2,5 |
| Eutrophication, kt PO4 | 0,0064 | 0,0004 | 0,0012 | 0,0080 | 0,0046 | 0,0206 |

Table 5-8: Environmental impact of residential ventilation products installed in 2005, emissions to water

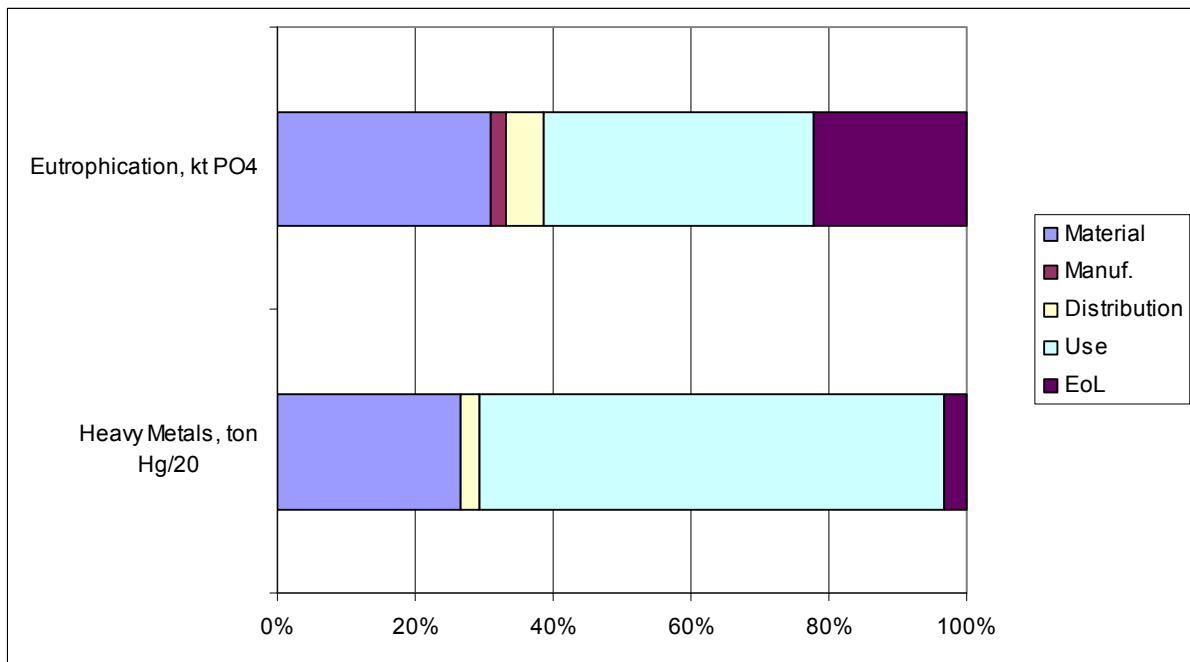

Figure 5-4: Environmental impact of residential ventilation products installed in 2005, emissions to water

Total expenditure for the end-user was reported in table 5.5.

5.4.2 Impact and LCC of all products in 2005

The total weight of all products in use in 2005 is about 80 kt. Materials and their end of life fate is shown in the figure below.

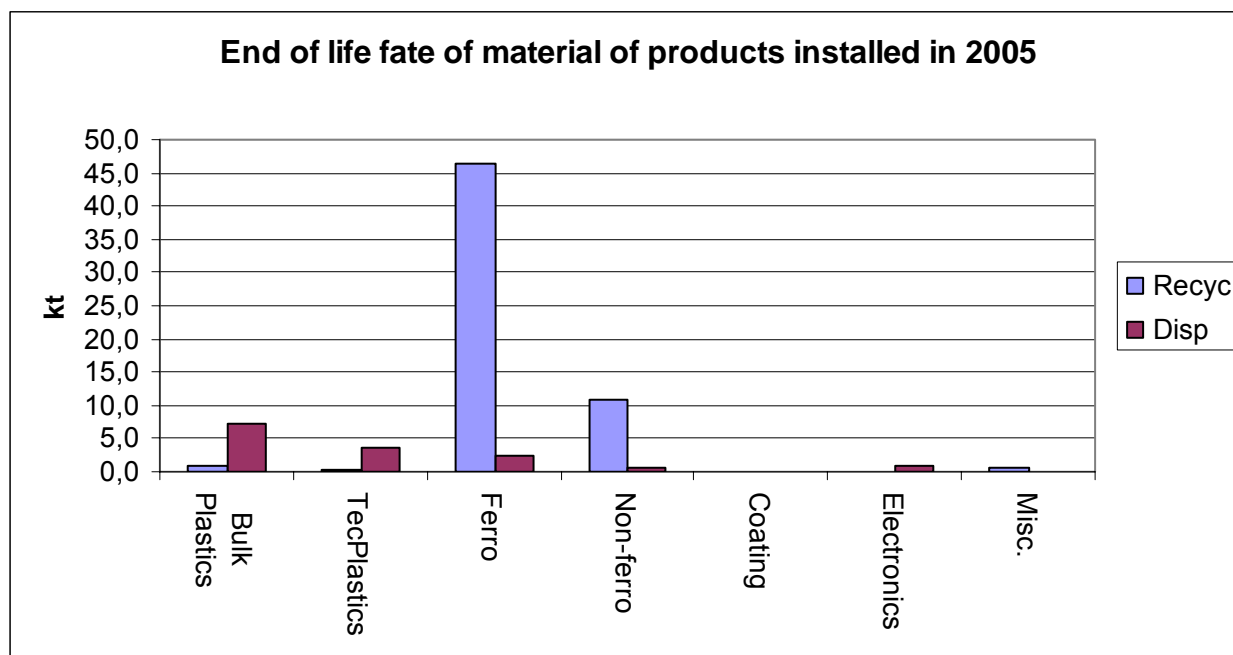

Figure 5-5: End of life fate of material of all residential ventilation products in 2005

Concerning other resources and waste,

| | Material | Manuf. | Distribution | Use | EoL | TOTAL |
|--|----------|--------|--------------|-------|------|-------|
| Total Energy (GER),PJ | 3,7 | 0,9 | 91,8 | 228,3 | 0,8 | 325,6 |
| of which, electricity (in primary PJ) | 0,5 | 0,5 | 0,2 | 228,2 | 0,0 | 229,4 |
| Water (process), mln. m3 | 0,4 | 0,0 | 0,0 | 15,2 | 0,0 | 15,6 |
| Water (cooling), mln. m3 | 0,4 | 0,2 | 0,0 | 608,6 | 0,0 | 609,2 |
| Waste, non-haz./ landfill, kt | 145,7 | 3,8 | 44,5 | 265,9 | 4,5 | 464,5 |
| Waste, hazardous/ incinerated, kt | 0,3 | 0,0 | 0,9 | 5,3 | 10,7 | 17,2 |

Table 5-9: Environmental impact of all residential ventilation products in 2005, energy, water and waste

Over their lifetime, all residential ventilation products sold in 2005 will consume 21.1 TWh between 2005 and 2015.

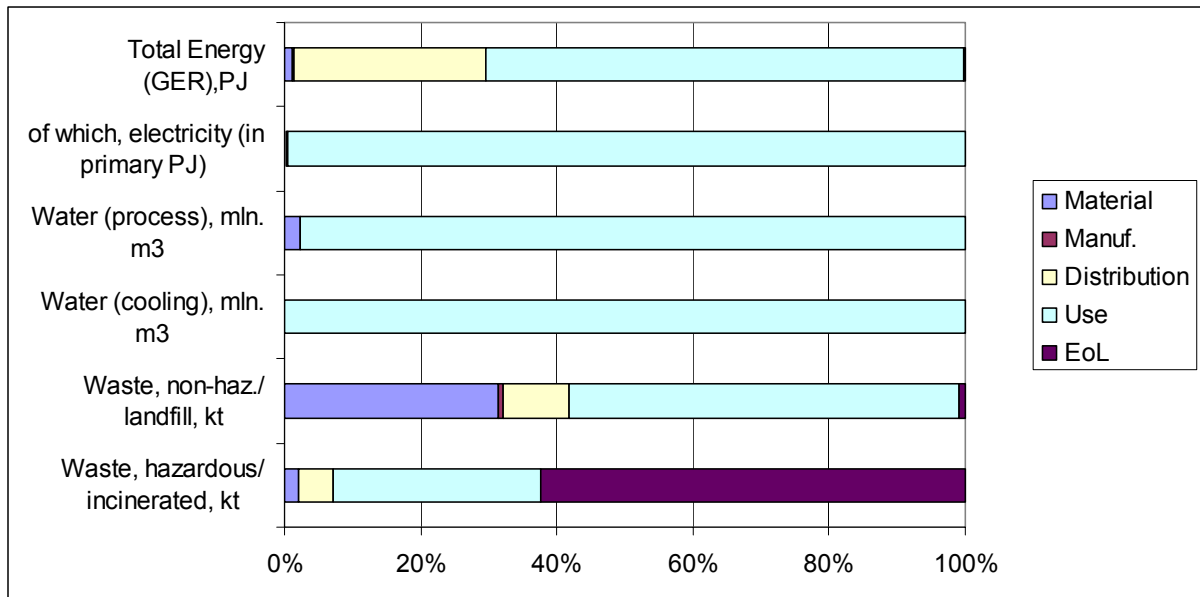

Figure 5-6: Environmental impact of all residential ventilation products in 2005, energy, water and waste

| | Material | Manuf. | Distribution | Use | EoL | TOTAL |
|---|----------|--------|--------------|------|-----|-------|
| Greenhouse Gases in GWP100 (Mt CO2 eq) | 0,2 | 0,1 | 5,4 | 10,0 | 0,1 | 15,7 |
| Acidification, emissions, kt SO2 eq. | 1,9 | 0,2 | 16,7 | 58,8 | 0,1 | 77,8 |
| Volatile Organic Compounds (VOC), kt | 0,0 | 0,0 | 1,4 | 0,1 | 0,0 | 1,5 |
| Persistent Organic Pollutants (POP), g i-Teq | 0,9 | 0,1 | 0,3 | 1,5 | 0,0 | 2,7 |
| Heavy Metals, ton Ni eq. | 0,4 | 0,2 | 2,3 | 3,9 | 0,3 | 7,0 |
| PAHs, ton Ni eq. | 0,9 | 0,0 | 3,0 | 0,5 | 0,0 | 4,3 |
| Particulate Matter (PM, dust) | 0,3 | 0,0 | 229,9 | 1,3 | 1,3 | 232,8 |

Table 5-10: Environmental impact of all residential ventilation products in 2005, emissions to air

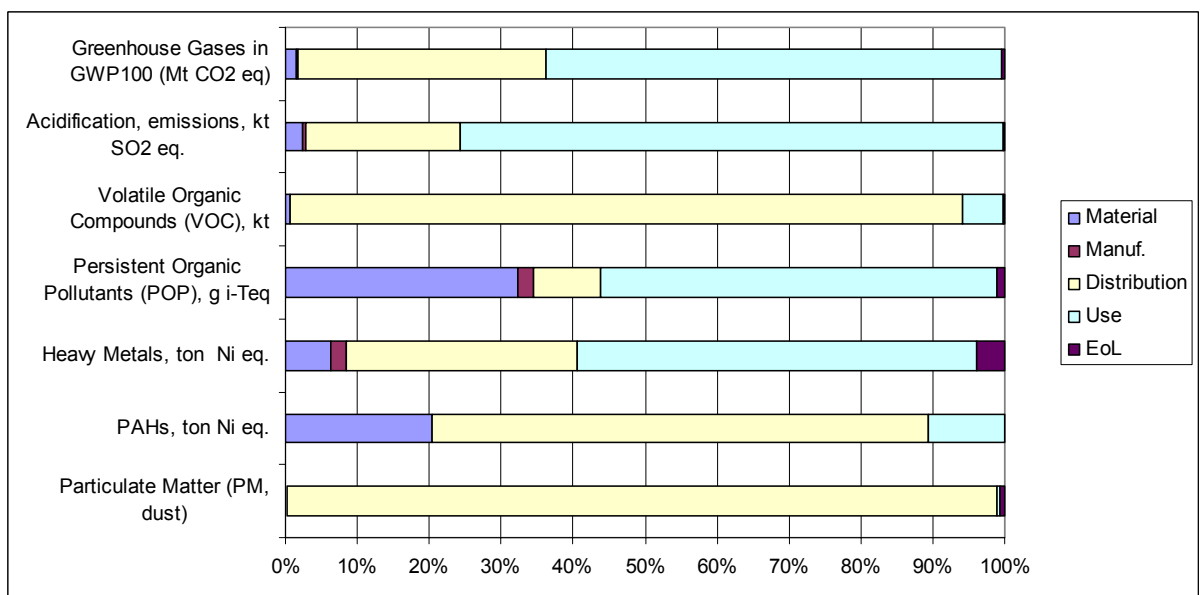

Figure 5-7: Environmental impact of all residential ventilation products in 2005, emissions to air

| | Material | Manuf. | Distribution | Use | EoL | TOTAL |
|--|----------|--------|--------------|-----|-----|-------|
| Heavy Metals, ton Hg/20 | 0,7 | 0,0 | 0,1 | 1,5 | 0,1 | 2,3 |
| Eutrophication, kt PO4 | 0,0 | 0,0 | 0,0 | 0,0 | 0,0 | 0,0 |
| Persistent Organic Pollutants (POP) | neg | neg | neg | neg | neg | Neg |

Table 5-11: Environmental impact of all residential ventilation products in 2005, emissions to water

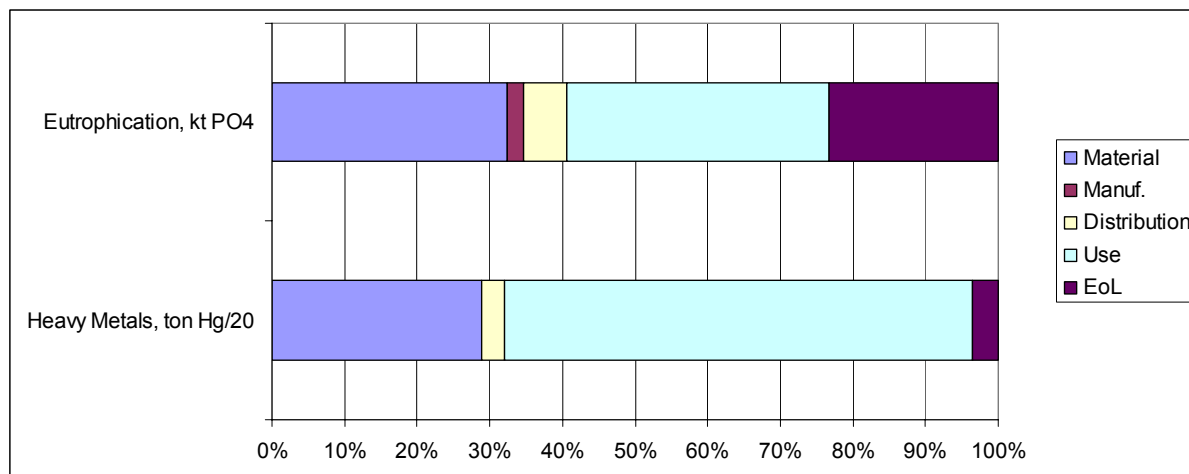

Figure 5-8: Environmental impact of all residential ventilation products in 2005, emissions to water

Total expenditure for the end-user was reported in table 5.5.

5.5 EU-25 Total System Impact

Using the estimates of task 4 to estimate the total environmental impact of the product system and compare with outputs from input/output analysis (e.g. EIPRO study).

Electricity consumption during use phase of installed products is 21,1 TWh. About two thirds are for collective dwellings. The table below gives the repartition by member state for EU25.

Table 5-12: Total electricity consumption of residential ventilation, EU 25 2005

| Estim.3 Energy GWh | DV fans in use continuous | DV fans in use On/off | DV hoods in use On/off | DV&HR in use Cont. | ICV in use 1 or 2 dwelling | ICV&HR in use 1 or 2 dwell. | CCV in use Coll. Dwell. | CCV&HR in use Coll. Dwell. | Total |
|--------------------------|---------------------------------|-----------------------------|---------------------------------|--------------------------|-------------------------------------|--------------------------------------|----------------------------------|-------------------------------------|--------------|
| EU-25 | 674 | 337 | 2379 | 29 | 2888 | 359 | 14315 | 127 | 21110 |
| A | 13,74 | 6,87 | 48,51 | 4,97 | 41,38 | 8,19 | 16,46 | 0,00 | 140,11 |
| B | 23,31 | 11,65 | 82,26 | 0,00 | 411,31 | 14,07 | 220,08 | 0,00 | 762,68 |
| CY | 1,03 | 0,52 | 3,65 | 0,00 | 0,23 | 0,00 | 37,59 | 0,00 | 43,03 |
| CZ | 9,72 | 4,86 | 34,31 | 0,00 | 1,95 | 0,00 | 424,97 | 0,00 | 475,81 |
| DK | 3,14 | 1,57 | 11,10 | 0,00 | 113,75 | 55,12 | 476,98 | 25,26 | 686,93 |
| EST | 1,29 | 0,65 | 4,57 | 0,00 | 0,12 | 0,00 | 53,34 | 0,00 | 59,97 |
| FIN | 3,84 | 1,92 | 13,54 | 0,00 | 71,39 | 72,76 | 476,06 | 50,88 | 690,39 |
| F | 32,14 | 16,07 | 113,43 | 0,00 | 903,74 | 48,49 | 2316,74 | 0,00 | 3430,62 |
| D | 158,36 | 79,18 | 558,91 | 23,54 | 470,79 | 38,84 | 80,96 | 0,00 | 1410,56 |
| GR | 16,52 | 8,26 | 58,31 | 0,00 | 3,99 | 0,00 | 295,20 | 0,00 | 382,28 |
| H | 8,57 | 4,28 | 30,24 | 0,00 | 2,35 | 0,00 | 228,65 | 0,00 | 274,09 |
| IRL | 14,68 | 7,34 | 51,81 | 0,00 | 5,29 | 0,00 | 6,20 | 0,00 | 85,32 |
| IT | 71,27 | 35,64 | 251,55 | 0,00 | 3,61 | 0,00 | 3430,63 | 0,00 | 3792,69 |
| LT | 2,09 | 1,04 | 7,36 | 0,00 | 0,14 | 0,00 | 82,33 | 0,00 | 92,96 |
| LIT | 3,07 | 1,53 | 10,83 | 0,00 | 0,41 | 0,00 | 115,97 | 0,00 | 131,82 |
| LUX | 0,88 | 0,44 | 3,11 | 0,00 | 15,75 | 0,60 | 14,74 | 0,00 | 35,51 |
| MT | 0,56 | 0,28 | 1,97 | 0,00 | 0,11 | 0,00 | 14,78 | 0,00 | 17,69 |
| NL | 22,53 | 11,26 | 79,52 | 0,00 | 602,58 | 41,86 | 503,04 | 0,00 | 1260,80 |
| PL | 31,28 | 15,64 | 110,39 | 0,00 | 8,43 | 0,00 | 1345,77 | 0,00 | 1511,50 |
| P | 18,57 | 9,29 | 65,56 | 0,00 | 8,13 | 0,00 | 167,74 | 0,00 | 269,29 |
| SK | 46,35 | 23,17 | 163,59 | 0,00 | 9,14 | 0,00 | 1370,24 | 0,00 | 1612,48 |
| SLO | 3,17 | 1,58 | 11,18 | 0,78 | 12,96 | 1,28 | 0,74 | 0,00 | 31,69 |
| E | 61,54 | 30,77 | 217,20 | 0,00 | 15,81 | 0,00 | 1454,05 | 0,00 | 1779,37 |
| S | 8,88 | 4,44 | 31,35 | 0,00 | 160,69 | 77,87 | 963,67 | 51,04 | 1297,94 |
| UK | 117,62 | 58,81 | 415,11 | 0,00 | 24,62 | 0,00 | 218,61 | 0,00 | 834,77 |

Table 5-13: Total environmental impact of the stock of ventilation fans between 2005 and 2025

| | | Main life cycle indicators | | | | |
|--|------------|----------------------------|--------------|--------------|--------------|--------------|
| | | 2005 | 2010 | 2015 | 2020 | 2025 |
| | | Resources and waste | | | | |
| Total Energy (GER) | PJ | 325,6 | 367,1 | 410,9 | 457,0 | 505,6 |
| of which, electricity | TWh | 21,9 | 24,5 | 27,3 | 30,2 | 33,3 |
| Water (process)* | mln.m3 | 15,6 | 17,5 | 19,4 | 21,5 | 23,7 |
| Waste, non-haz./ landfill* | kton | 464,5 | 521,2 | 581,0 | 644,0 | 710,5 |
| Waste, hazardous/ incinerated* | kton | 17,2 | 19,2 | 21,3 | 23,5 | 25,9 |
| | | Emissions (Air) | | | | |
| Greenhouse Gases in GWP100 | mt CO2eq. | 15,7 | 17,8 | 19,9 | 22,2 | 24,5 |
| Acidifying agents (AP) | kt SO2eq. | 77,8 | 87,6 | 97,9 | 108,8 | 120,3 |
| Volatile Org. Compounds (VOC) | kt | 1,5 | 1,7 | 1,9 | 2,2 | 2,4 |
| Persistent Org. Pollutants (POP) | g i-Teq. | 2,7 | 3,1 | 3,4 | 3,7 | 4,1 |
| Heavy Metals (HM) | ton Ni eq. | 7,0 | 7,9 | 8,9 | 9,9 | 10,9 |
| PAHs | ton Ni eq. | 4,3 | 5,0 | 5,6 | 6,3 | 7,0 |
| Particulate Matter (PM, dust) | kt | 232,8 | 266,2 | 301,4 | 338,4 | 377,5 |
| | | Emissions (Water) | | | | |
| Heavy Metals (HM) | ton Hg/20 | 1,4 | 2,6 | 2,9 | 3,2 | 3,5 |
| Eutrophication (EP) | kt PO4 | 0,007 | 0,022 | 0,024 | 0,026 | 0,029 |
| *=caution: low accuracy for production phase | | | | | | |

Total impact is of the same order of magnitude as for air conditioners for the stock of products in 2005 but the stock and environmental impact growth is slower than for air conditioning according to the hypothesis made in both studies.

Task 5 summary

Energy is a major contributor to the environmental impact of residential ventilation.

The share of energy in the life cycle cost of the product may represent from 13 % for hoods that are supposed to be used two hours a day to 88 % for decentralized ventilation that are used continuously. 73% of Total Energy use, 100% of electricity use, 98% of Water (process) rejection, 100% of Water (cooling) rejection, 60% of Waste, non-hazardous going to a landfill and 34% of Waste, hazardous to be incinerated are generated in the use phase, in relation with energy consumption.

It is also to be noted that the environmental impact of residential ventilation products is largely dominated by collective ventilation for about two thirds of all impacts with energy consumption of about 14 TWh in 2005 over 21 TWh for the whole end-use.

Total impact is of the same order of magnitude as for air conditioners for the stock of products in 2005 but the stock and environmental impact growth is slower than for air conditioning according to the hypothesis made in both studies.

Given that task 4 enlightened a factor of 3 to 5 between the best and worst efficiency of residential ventilation products, the perspective of energy consumption and CO₂ emissions cut is significant.

6 TECHNICAL ANALYSIS BAT

6.1 State-of-the-art in applied research for the product inside and outside Europe

The actions leading to improvement in ventilation systems are split between the ones that can be implemented on the ventilation product itself, and some others that can be applied in the specification or design of buildings which take place in the frame of national or regional building codes, and also habits and traditions. If we had the degree of freedom of national building codes, we would need in principle a technical analysis not only of available technology for products, but also a technical analysis of potential gains at the level of the full ventilation system, by simulating completely air and heat movement into the building, which is not the scope of this study. In our scope is certainly the improvement of the fan and motor in the single flow system and their control. The case of double flow when building codes consider that heat recovery is justified will be discussed later.

Just to mention what is outside of our scope: an improvement of the ventilation systems implies the selection and control of a well chosen flow rate of air depending on sanitary considerations, the work on the construction products to reach the proper control of inlets for air entrance (possibly self controlling air flow), the selection of extracts adequate to each room (the type of control being adequate to the source of pollutants inside the room), a control system to modulate and balance the flow, correct fitting, anti-leakage treatment and insulation of the air ducts, provision for maintenance of the full system.

Our scope is to consider the improvement of the product itself, for external conditions given and accepted as they are. The analysis of the environmental balances shows that energy in use phase is by far the largest environmental impact, the one we have to concentrate on (2/3 of energy is for use phase, explaining most of global warming and acidification impacts, while the others are rather negligible).

There are no improvements that could be proposed by parts suppliers, since the EU manufacturers have a full control of their technology. In a similar way, there is no reason to give a special importance to the ventilation products manufactured abroad, as lot 11 already stated. The manufacturers inside the European Union are well known for the quality and efficiency of their products. They are serving not only the European but the international market. So we have not found better products outside the EU. Instead cheap but low efficient products produced in some countries which are entering the European market tend to lower the efficiency levels. Products from these low wages countries are typically not designed using CFD to optimise blades, using low efficient AC motors and often simple straight sheet metal blades. So these products can not help to increase efficiency of the products but instead are lowering the average efficiencies as they are imported and used in Europe due to their highly competitive price in first cost.

6.2 Improvements in motor design

To keep prices down, manufacturers use inexpensive motors. We can have access to some values for small motors and we can extrapolate some values of lot 11 to a smaller range.

The lowest cost motor is the one phase shaded pole motor (“squirrel”) which can be substituted by “collector” or “universal” motors with an efficiency increase estimated by some as a transition from 20% to 40%. The real improvement on the market has been the introduction of motors with electronic commutation that can be recognised because they can operate in DC, which are said to be able to reach 80 to 90 % according to stakeholders. EC-Motor Electronically commutated direct current motors are

equivalent to brushless DC motors. They provide a better efficiency and an efficient way to make speed vary.

Figure 6.1 is a curve provided by a stakeholder showing the efficiency of the asynchronous motors (either 1 phase or 3 phase) and the efficiency of the EC (Electronic Commutation) motor.

Figure 6-1: Efficiency of different motors, courtesy EbmPapst

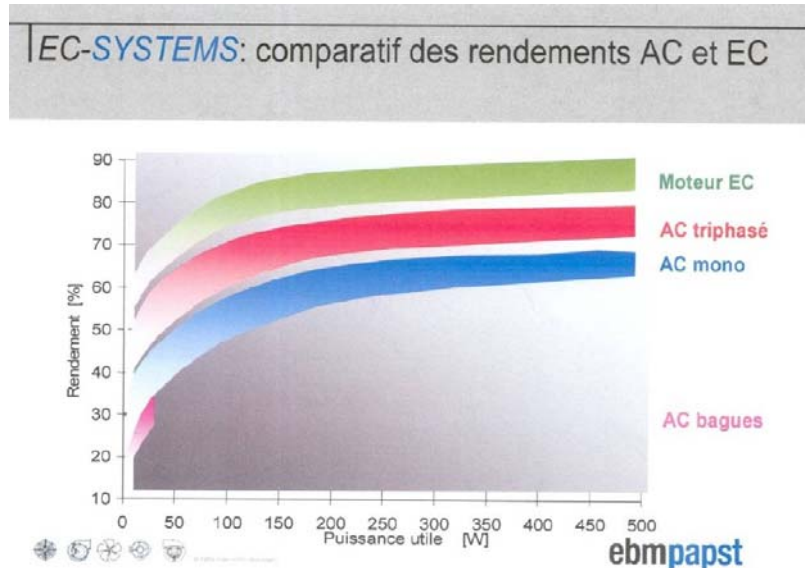

We keep a value of 70% efficiency for such EC motors in our size. One stakeholder has given all the data on one example of the same turbine equipped with two motors and put in the same duty conditions (340 m³/h, 100 Pa): the asynchronous motor requests 98 W, when the electronic commutation motor demands only 58 W, a 60 % saving, a change in efficiency from 9,64 % to 13,89 %. This fits well with our estimate of efficiency increase from 40% to 70%.

Lot 11 gives some indications that allow to check if there is an environmental impact in the transition from classic motors to EC motors. However the values are for power levels 5 to 10 times larger than our motors and the EFF1 or EFF2 motors are already better than our basic motors. However this gives us confidence in the lack of adverse environmental effects of the improvement of motors.

Table 6-1: BOM of an improved motor according to lot 11

| Table 7-13 BoM for 1,1 kW EC Motor | |
|------------------------------------|-------------------|
| Materials | Motor Rated Power |
| | 1,1 kW |
| Steel (kg/kW) | 1,8 |
| Aluminium die-cast (kg/kW) | 2,1 |
| Ferrite (kg/kW) | 1,0 |
| Copper (kg/kW) | 0,75 |
| Plastic (kg/kW) | 0,26 |
| PWB (kg/kW) | 0,09 |
| Electronic components (kg/kW) | 0,1 |

Table 6-2: BOM of a standard motor according to lot 11

Table 4-1, shows BoMs for IE1/EFF2 motors of the agreed reference output powers.

Table 4-1 Bill-of-Materials for EFF2 motors (materials average values).

| Materials | Motor Rated Power | | |
|-----------------------------|-------------------|-----------------|--------|
| | 1,1 kW | 11 kW | 110 kW |
| Electrical steel (kg/kW) | 5,40 | 3,60 | 3,10 |
| Other steel (kg/kW) | 1,50 | 0,95 | 0,67 |
| Cast iron (kg/kW) | 2,5 (0,0 - 5,0) | 1,3 (0,0 - 2,0) | 3,00 |
| Aluminium (kg/kW) | 1,7 (0,5 - 2,5) | 0,9 (0,2 - 1,5) | 0,18 |
| Copper (kg/kW) | 1,24 | 0,64 | 0,54 |
| Insulation material (kg/kW) | 0,05 | 0,02 | 0,01 |
| Packing material (kg/kW) | 1,00 | 0,90 | 0,50 |
| Impregnation resin (kg/kW) | 0,30 | 0,10 | 0,05 |
| Paint (kg/kW) | 0,10 | 0,05 | 0,01 |

Our interpretation of lot 11 values in the following table shows a decrease of mass and some variations of materials use that we could import into the Ecoreport.

Table 6-3: BOM comparison from lot 11

| | EFF1 | EFF2 | EC-Brushless |
|------------------------|-------|-------|--------------|
| Steel | 58% | 54% | 30% |
| Iron | 15% | 20% | 16% |
| Aluminium | 13% | 13% | 34% |
| Copper | 11% | 10% | 12% |
| Plastics | 2% | 3% | 6% |
| Electronics | 0% | 0% | 2% |
| Total mass (kg) | 16,55 | 12,69 | 6,1 |

The change in motor cannot result in a large change in environmental impact in production phase or at end of life.

Our values for efficiency improvement seem also compatible with the following graph of the annex 3.1 of lot 11 report.

Figure 6-2: Efficiency of motors according to lot 11

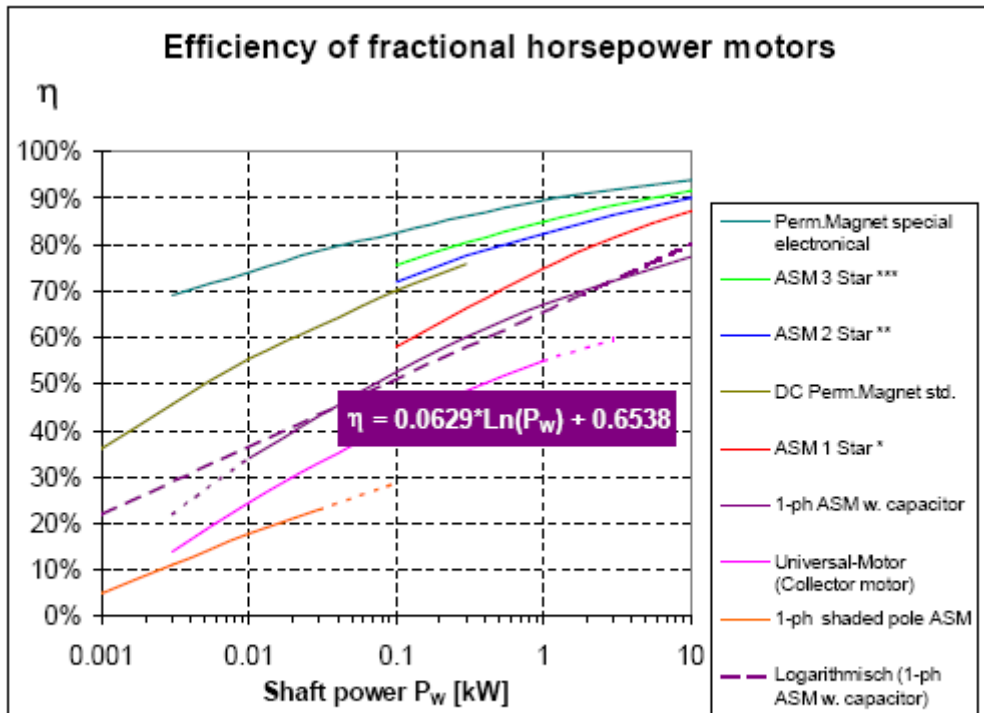

Figure 138: Efficiency of fractional horsepower motors [Nipkow, 2007]

6.3 Improvements in fan design

Another source of difference between products after the change of motor would be in the design of the air movement inside the product. Here we give an image of potential improvements in the fan itself. Like lot 11 we refer to AMCA for definitions (see annex).

The aerodynamic losses can be significantly reduced by aerofoil bladed design (curved and twisted profiles instead of flat plastic or metal blades) and additional features such as winglet as the end of the profile to reduce tip losses. Aerofoil blade designs are today designed using CFD software as we could see when visiting the development laboratories; however production of such complex geometries is much more expensive, and the products are often submitted to the requisites of low cost manufacturing, namely constant width of fans.

In practice, axial flow fans are frequently of the tube-axial type (i.e., without guide vanes). The rotational energy at the outlet is lost and real efficiency on blowing systems is often moderate. Replacement by, or modification to, the vane-axial alternative should give a higher usable efficiency. The axial fans of 100 to 150 mm diameter can hardly reach 20% mechanical efficiency with present geometry, often less because of manufacturing constraints deriving from cost objectives.

The centrifugal impellers are forward curved. Transition to backward curved impellers is seen as costly by the stakeholders in residential applications since the higher speed needed (for instance 2000 rpm instead of 1000 rpm for the same flow) necessitate a strong acoustic treatment, far more than what is done for the medium range products. The smaller and cheap mass-produced centrifugal fans with ladder strip impellers (forward) often can hardly achieve 60 % with an evenly distributed flow. It is possible that backward curved impellers permit a higher performance like 70%, or at least the same. When forward curved rotors are put in situation of “lateral fixing” where the motor opposes to air distribution the flow is poorly distributed on the blades and some stakeholders have estimated the efficiency to 40% or less.

6.4 Improvements in interior air flow design

The aerodynamic losses can be significantly reduced by interior design, balancing of flow, etc. Such interior surfaces could be designed using CFD software; however production costs often prevent the addition of the interior surfaces that would ease the flow. The state of the art seems very different in the case of hoods (large spaces, balancing effect of the grease filter), in the case of extractors which can in some cases still include a lot of elbows and in the case of axial flow, that are still sold without guide vanes. We have a very rough estimate of the potential gain because it has to be designed on a case by case basis, and has been indicated as being of the order of 10% in one case by one stakeholder.

6.5 Improvements in motor and fan control

Single speed

If no provision is made for varying the flow (continuously or not), fan performance is controlled or adjusted for once by means of a damper, either on the inlet or on the outlet, creating a variable additional system resistance, and a considerable loss of performance. The same type of permanent adaptation of the fan can be obtained by changing its feed voltage.

Multi speed

There are three modes of reduction of mechanical power that do not have the same efficiency 1-suppression of voltage in some circuits 2- through electronics then 3-by a chopper. They are selected by the manufacturer according to the range and image of the product.

Speed can be really varied in various ways : either by steps by feeding part of the electrical wiring of the motor (which loses performance) or thanks to a variable speed motor (inverter, slipping coupling, vane control, or a gearbox). We call these two solutions respectively multi speed and variable speed.

Variable speed

Variable speed control is now frequent with a variable speed motor. Vane control controlling the swirl at the fan inlet or variable blade pitch control (normally only for axial-flow fans), adjustable pitch are not used in such small products.

The first family of gains : direct user control of multispeeds

The small axial products do not have various speeds.

In centrifugal ICVs there is a manual selection of the speed, that can be remote. Very often the highest speed is associated in some way (position, logo) with the use of the “passive” cooking hood.

The cooking hoods have many speeds and the highest is often called booster or intensive and left apart in publication of standard testing results, a fact that we will discuss later to know if we can accept it.

The second family of gains : adaptation to of speed to balance a pressure which varies with demand.

The fan is determined by the maximum flow demand and by the minimum pressure demanded at that flow. These are the two extremes of the characteristic curve. When all ATDs are open there should be enough pressure everywhere. To be energy efficient, the fan should have a “flat” characteristic curve to adapt to variations of flow due to opening and closing of extractions: the flow could vary but the pressure would not increase.

Figure 6-3: Constant pressure fan characteristic

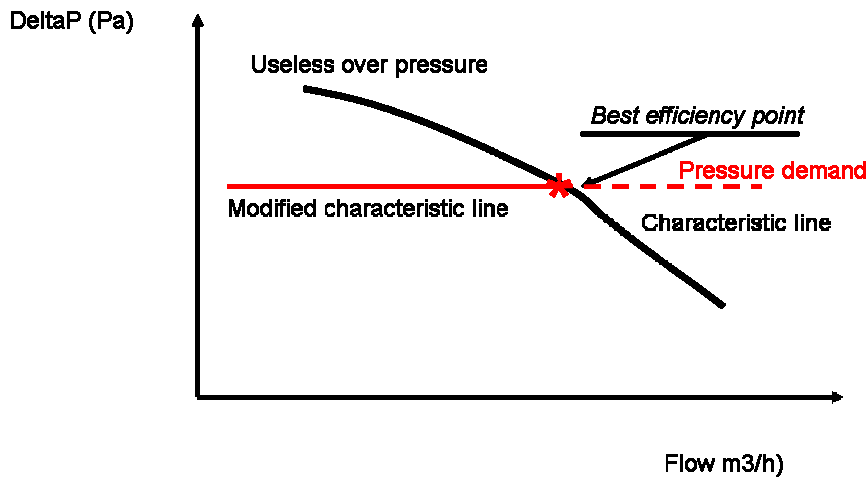

The fan by itself cannot have such a flat curve. The solution is to keep the pressure constant. It is used for large systems presently, and we have called this type of characteristic curve type (f) in part 4, and it could be adapted for smaller products.

The third family of gains : demand controlled ventilation.

Ventilation should be adapted to real needs

- people (CO₂, H₂O, odours),
- cooking (CO₂, H₂O, odours)
- which vary a lot over time.

First let's consider real electronic sensing of pollutants. In non residential buildings there are high and typical values of gains published (CFP, 2006): 40 to 70% if there is a real measure of presence (CO₂ or movement detection), 20 to 40% if there is only a detection by Yes or No of presence. However this is often not reflected at extractor level, so that about the same electricity is used. When the extractor has the information and if it can adapt, significant gains in electricity are possible. There is a system used for large rooms that could be used in smaller applications providing variable flow (depending on sensed occupation) in an original way. Instead of varying continuously the flow (which is a source of unbalance, poor distribution of the fresh air in the room and requires more costly equipment) they operate at full speed but part of the time (for instance three minutes in a sensing time step of 10 minutes). Nothing of that is available in the field of residential ventilation. On total electronic sensing of demand has to be considered as a BNAT, not a BAT

In dwellings we find some mechanical systems performing partly the same function but locally : the usual variable deciding on the flow in such systems is water content measured by the relative humidity on a psychometric mesh. The flow is adapted (without motor: it's a purely mechanical system). The water content flow control of the ATDs generates energy savings, improves comfort (relative humidity remains in the zone of comfort in comfort standards and adapts to outside conditions (outside air moisture and temperature). A simpler adaptation of the motor speed is made with the objective of maintaining a pressure at some point constant while the extracts adapt locally but not perfectly to conditions, and generate additional headlosses.

The key point of gains in BAT : adaptation of the motor speed for decreasing pressure demand.

A further variation of line (f) is a promising BNAT and will be called type (g). There is still a potential gain because of the decrease of headlosses in the distribution network when the flow is reduced. At part load the pressure demand of the network is even lower than the pressure demand at full load.

In principle, by varying the speed one could obtain a tilted line, like:

Figure 6-4: Variable speed fan characteristic

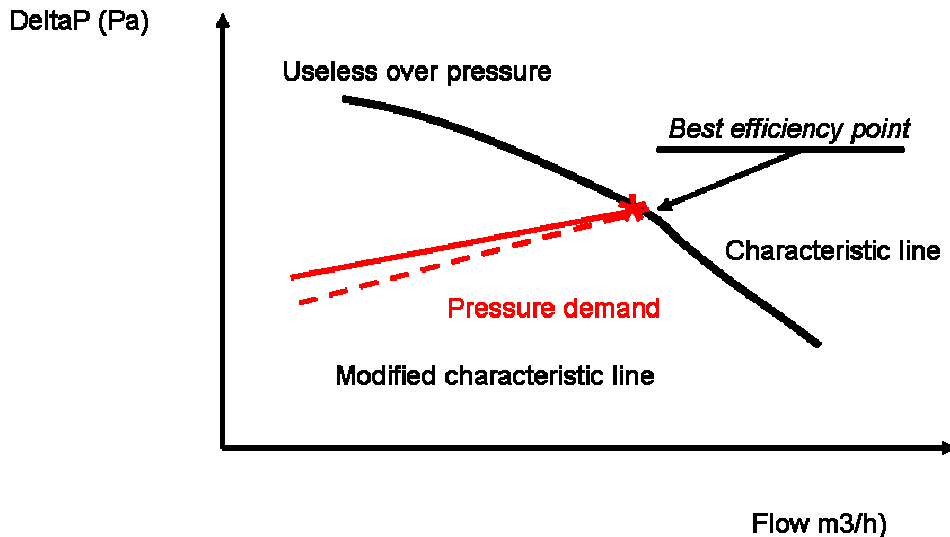

This a NABT, that is not really on the market, even if discussed by manufacturers.

6.6 Limitation of electric demand in case of heat recovery.

This type of option is not usually combined with the previous one. Either we try to lower the flow of fresh air, or we try to heat it up, at a reasonable and constant flow.

Studying this double flow system is an option permitted by the new CEN standard derived from the EPBD directive. The benefits are: obtaining of a certain air change room by room not depending on what happens in the other rooms, on the pressure field on the outside, the possibility to filter the incoming air (usual filters are G4/F5). There are additional components in this new system: additional air ducts, flow rate controllers (demanding an overpressure between 50 and 150 Pa) or calibrated dampers, demanding new balancing operations if the installer is trained for this. Installation and maintenance become more complex. Double flow provides also the opportunity for a heat exchanger (heat recovery), for preheating or cooling of air (neutral air entrance in the building, more comfortable), requesting then some insulation of the air ducts.

When we add a heat pump in a balanced double flow this complex system provides an alternative to classic air conditioners in moderate climates.

The design of the building shell for double flow system is different from the case of single flow: less air inlets. Even with less inlets there is a significant air entrance because the building is not in underpressure and all sides of it may leave air in. This may be a problem for retrofit if double flow is the retrofit option: in France a professional rule says that the building envelope should be first treated to lower infiltration down to 0.6 ACH to allow double flow ventilation.

The double flow system is more easily integrated in non residential buildings (where the additional air ducts can be easily hidden, or even shown) than in residences where they cannot be easily integrated, nor shown. Also in non residential buildings constant flow is more often used.

The heat exchanger can be a static one or a rotating one. This last solution is, relatively common in non residential buildings in the USA. In small sizes those rotating heat exchangers are substituted by static ones made of ondulated aluminium plates.

Effectiveness is defined and measured in standard EN 13141-7. For static heat exchangers, effectiveness between 50 and 99% is reported, presumably depending on flow organisation and area. Any higher efficiency is usually correlated with more head losses, so more electricity consumption. Here again a gain in final energy may disappear when converted in primary energy. Rotating heat exchangers have effectiveness in the 70-80% range.

Heat exchangers have to be protected by filters against fouling, sometimes only G1, often G3 or G4. For a better air quality a second filtering stage between F5 to F7 is often proposed, or even F8 (against pollens). Filters increase even more the headlosses and the electricity demand of the product. When they are colmated they leave dust go along. Some systems indicate the need to change the filters. We suggest here again to take away the filters for testing in order to get values comparable with other products. Heat exchangers used in balanced flow system are subject to freezing like heat pumps and request electric heating at low temperatures.

Some balanced flow systems may provide additional air heating after the heat exchanger either by electricity or by hot water. A bypass on the fresh air can be activated for mid seasons, to provide some cooling at higher flow.

The double flow has significant benefits that can be found at system level. It is not an option that can substitute our base case, it is a full system, including a double circulation of air ducts. The Heat Recovery option will use more energy in our product, and the benefit can only be found in the heating and cooling bill, not in the ventilating bill.

Due to the various factors analysed our recommendation is that the manufacturers of equipment with heat recovery are not obliged in a first phase (that could last three years for instance) to enter into an information scheme for end users, because the method we propose is not sufficiently tested (testing with substitution of HR section by no headlosses pipes). They can however enter into the scheme if they want by considering their product as an extractor with the real extraction flow rate and half the electricity demand.

6.7 State-of-the-art for noise control

Ventilations systems should not only be efficient but also producing a low noise level. Compared to industrial and non residential applications the noise level of products in residential ventilation applications should be as low as possible. However, the simplest way of increasing performance is often to increase the flow and it has an interest to set limits on noise when trying to optimize the product, in order to avoid solutions that the market will not accept.

Limits on noise: a new approach. A small high tech company proposed an active treatment of noise in ventilation systems, which seem to interest one ventilation manufacturer (Direct, 1997).

Task 6 summary

Our scope is to consider the improvement of the product itself, for external conditions given and accepted as they are. The analysis of the environmental balances shows that energy in use phase is by far the largest environmental impact, the one we have to concentrate on.

The lowest cost motor is the one phase shaded pole motor (“squirrel”) which can be substituted by “collector” motors with an efficiency increase from 20% to 40%. The real improvement on the market has been the introduction of brushless DC motors. We keep a value of 70% efficiency for such EC motors.

The smaller and cheap mass-produced centrifugal fans with ladder strip impellers (forward) can hardly achieve 60 % with an evenly distributed flow. It is possible that backward curved impellers permit a higher performance like 70%, or at least the same. When the flow is poorly distributed on the blades we have estimated the efficiency to 40% or less. The axial fans of 100 to 150 mm diameter can hardly reach 20% mechanical efficiency. The aerodynamic losses can be also significantly reduced by interior design, balancing of flow, etc.

The direct user control of multispeeds is the first step of adaptation to demand. The cooking hoods have many speed and the highest is often called booster and left apart in publication of standard testing. The real demand controled ventilation becomes possible with variable speed. However the necessary sensors are not available : people and cooking (CO₂, H₂O, odours) which vary a lot over time. A simpler adaptation of the motor speed is made with the objective of maintaining a pressure at some point constant while the extracts adapt locally but not perfectly to conditions, and generate additional headlosses.

The Heat Recovery option will use more energy in our product, and the benefit can only be found in the heating and cooling bill, not in the ventilating bill.

7 IMPROVEMENT POTENTIAL FOR THE PRODUCT OF AVERAGE SIZE

Scope: Identify design options, their monetary consequences in terms of Life Cycle Cost for the consumer, their environmental costs and benefits and pinpointing the solution with the Least Life Cycle Costs (LLCC) and the Best Available Technology (BAT).

The assessment of monetary Life Cycle Costs is relevant to indicate whether design solutions might negatively or positively impact the total EU consumer's expenditure over the total product life (purchase, running costs, etc.). The distance between the LLCC and the BAT indicates—in a case a LLCC solution is set as a minimum target—the remaining space for product-differentiation (competition). The BAT indicates a medium-term target that would probably be more subject to promotion measures than restrictive action. The BNAT (subtask 6.5) indicates long-term possibilities and helps to define the exact scope and definition of possible measures.

7.1 Options partly in place in some products

First we established a list of the penetration of BAT because some are used in some products and not in the others and this transfer of BAT from one family to another is already part of the optimisation potential. The table gives the indicative penetration of each BAT of chapter 6 in the range of products defined. Improvements related with rotation speed can be used in the product but may be limited by the building codes which define pressure levels requested at lower flows. These improvements cannot have the same level of implementation as the full load improvements.

Table 7-1: Improvement potential of the different residential ventilation products

| Estimated penetration of BAT in |DV hoods |DV not hoods |ICV | Observations | Partial Eff. gain |
|---------------------------------------|---------------|-------------------|----------|---------------------------------------|-------------------|
| Motor ↗ 1 st improvement | 9 % | 0 % | 90 % | 1 phase shaded pole ↗ up to collector | 20 ↗ 30 % |
| Motor ↗ 2 nd improvement | 1 % | 0 % | 50 % | Collector ↗ up to Asynchronous | 30 ↗ 40 % |
| Motor ↗ 3 rd improvement | 0 % | 0 % | 1 % ? | ↗ Electronic commutation | 40 ↗ 70 % |
| Axial ↗ Cent lateral fix | 90 % | 0 % | 100 % | Size problems | 20 ↗ 40 % |
| Cent lat ↗ Cent. central fix | 10 % | 0 % | 10 % | Size problems | 40 ↗ 60 % |
| Forward ↗ Backward | 1 % | | 1 % | More noisy (more speed) | 40 ↗ 60 % |
| Aeraulic design easing | 0 % | n.a. | 90 % | Not one simple level of efficiency | 10%? |
| Single Speed ↗ MS | 100 % | 1 % | 50 % ? | Position of speeds is a problem | ? |
| MS ↗ VS | 0 % | 0 % | 10 % | Not one simple level of efficiency | ? |
| Non flat blades | 1 % | 0 % | 1 % | Not one single level of efficiency | 10%? |

7.2 Impacts of options on a DV (not hood) of average size

The range of total efficiencies (starting from 1%) can only be explained if the less efficient motor is used with an axial flow turbine (leading to 4-5% total efficiency) and that some design errors are made in some models. The potential of gains is enormous if we use new technology : vanes, low speed centrifugal, etc. However, if we stick to BAT, the technical studies of chapter 6 indicates as first objective a general movement of fan efficiencies up to 40% with a 10% cost increase (a), and the same for the very small motors considered (b). Efficiency increases less than direct $z\% = x\% + y\%$ addition, typically following $(1-z\%) = (1-x\%)*(1-y\%)$. We estimated the total efficiency gain resulting from the combination as 19%. The absolute over costs do add: 20% increase. We have not introduced changes in BOM, following the analysis of chapter 6. This revolution would have lead to the following LCC changes, if it had taken place in 2005.

Table 7-2: LCC input and results of decentralised ventilation products

| LCC variations | Base case | Base case | (a) | (a) | (b) | (b) | (a+b) | (a+b) |
|--|------------|------------|------------|------------|------------|------------|------------|------------|
| | DV cont | DV interm | DV cont | DV interm | DV cont | DV interm | DV cont | DV interm |
| General characteristics | | | | | | | | |
| Power W | 17,0 | 17,0 | 15,3 | 15,3 | 15,3 | 15,3 | 13,8 | 13,8 |
| Elec. kWh | 148,9 | 12,4 | 134,0 | 11,2 | 134,0 | 11,2 | 120,6 | 10,0 |
| LCC input (euros) | | | | | | | | |
| Price | 30,0 | 30 | 31 | 31 | 31 | 31 | 32 | 32 |
| Installation | - | - | - | - | - | - | - | - |
| Maint. 4% | - | - | - | - | - | - | - | - |
| LCC unit (euros) | | | | | | | | |
| Product price | 30,0 | 30,0 | 31 | 31 | 31 | 31 | 32 | 32 |
| Installation costs | 0,0 | 0,0 | - | - | - | - | - | - |
| Electricity | 211,3 | 17,6 | 190,2 | 15,9 | 190,2 | 15,9 | 171,2 | 14,2 |
| Rep & maint. | 0,0 | 0,0 | 0,0 | 0,0 | 0,0 | 0,0 | 0,0 | 0,0 |
| TOTAL | 241,3 | 47,6 | 221,2 | 46,9 | 221,2 | 46,9 | 203,2 | 46,2 |
| Elec / total ratio | 88% | 37% | 86% | 34% | 86% | 34% | 83% | 28% |
| LCC of new products installed in 2005 (euros) | | | | | | | | |
| Number of products (M) | 0,3 | 4,4 | 0,3 | 4,4 | 0,3 | 4,4 | 0,3 | 4,4 |
| Product price | 9,5 | 133,2 | 10 | 137,6 | 10 | 137,6 | 10,1 | 142,1 |
| Installation costs | 0,0 | 0,0 | 0,0 | 0,0 | 0,0 | 0,0 | 0,0 | 0,0 |
| Electricity | 67,0 | 78,1 | 44,7 | 52,3 | 44,7 | 52,3 | 40,3 | 46,7 |
| Rep & maint. | 0,0 | 0,0 | 0,0 | 0,0 | 0,0 | 0,0 | 0,0 | 0,0 |
| TOTAL | 76,5 | 211,3 | 55 | 190,0 | 55 | 190,0 | 50,4 | 188,8 |
| Elec / total ratio | 88% | 37% | 85% | 34% | 85% | 34% | 83% | 28% |

Among the changes in environmental impact, the ones related with energy are the only significant, but they represent a large potential of improvement. The same product is used continuously or discontinuously and so it has a real meaning to study a weighted average of use scenarios.

7.3 Impacts of options on an ICV of average size

Case study 1 : three comparable models in the same manufacturer with one using two BATs

One stakeholder (one of the top runner manufacturers) has shown to us the impact of his choices of motor and fan quality. The comparison is made for a typical duty of 290m³/h @ 200Pa (overall pressure: internal plus external). He considered:

- a centrifugal blower with AC motor, forward curved impeller, 93W, 82 Euros

- a centrifugal blower with EC motor, forward curved impeller, 50W, 134 Euros
- a motorised impeller with EC motor, backward curved, 40W, 94 Euros (in fact a prototype, but simple to derive at no cost from an existing standard product).

The lower wattage for the same duty is impressive. The manufacturer insists on the decoupling between the change of motors and the change in blades, which makes motor selection the simplest way to improve efficiency. Today the blowers with AC motor are commonly used, but more and more companies switch to same blower but with EC motor as a redesign of the units is not necessary. **Gains are made at full load and at a significant overcost.**

Case study 2 : two comparable models in the same manufacturer with one optimized

On manufacturer (one of the top runner manufacturers) has given the data allowing to compare its basic ICV and a refined version obtained by flattening the characteristic curve (in direction of an horizontal pressure line) and improving motor fan efficiency.

Figure 7-1: Comparison of performance and efficiency characteristics of a standard and improved ICV

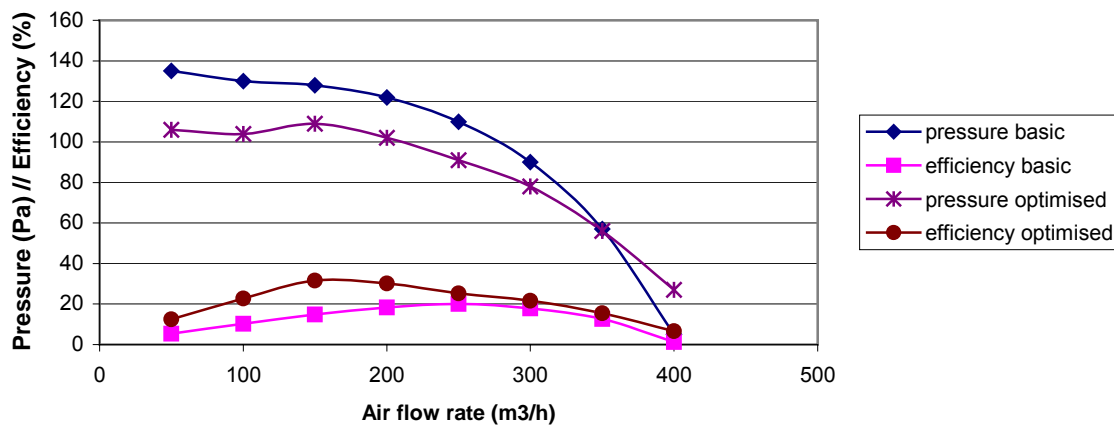

The best efficiency values are respectively 20,1 % (at 110 Pa) and 31,6 % (also at 110 Pa), based on full load. The yearly average power demand moves from 40 W to 28 W, a significant improvement. Public prices with tax are 234 and 342 Euros. **In this case gains are significant at full load, but relatively expensive to obtain.**

Case study 3 : two comparable models in the same manufacturer with one using multi speed

This is the example given by one manufacturer (one of the top runner manufacturers) when introducing a lower speed in an existing product. The grey line in the following graph represents this new speed created.

Figure 7-2: Comparison of performance and efficiency characteristics of a standard and improved ICV

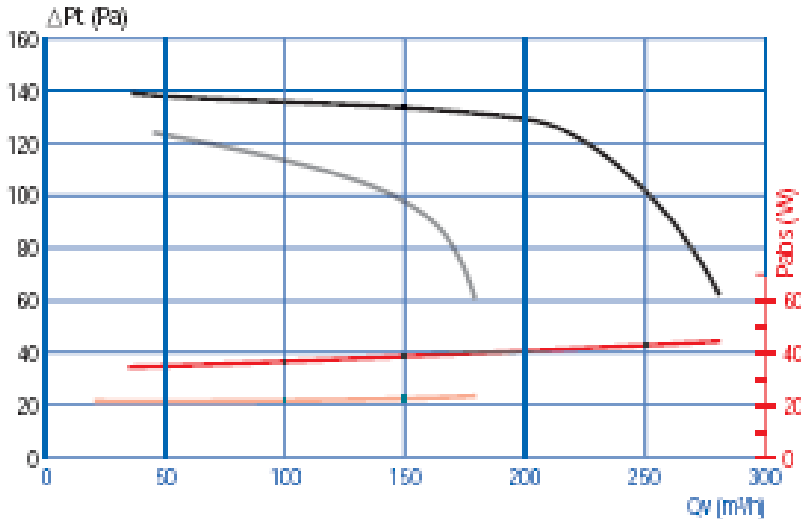

The lower speed does not change the EEI at full load which remains at 13.7%. The EEI (PL) is 17,6% for the one speed product and becomes 30% for the two speed product, displaying an enormous efficiency progression. Electricity consumption on a yearly basis goes down from 37 W to 26 W. The manufacturer has chosen to introduce the new equipment at the same price than the previous one, 192 euros, which does not mean that there is no over cost, but that its gains in productivity over the last years may cover this cost increase. Due to the nature of the improvement (electrical switch, new cabling of the motor) we estimate to 5% the over cost of multi speed. **Note that most gains are due to flow reduction and should be measured at part load.**

Summary of case studies

Let’s start from the reference situation in chapter 5: a 19% full load efficiency equipment. Based on the case studies 1 and 3, we can consider a 18% improvement in full load efficiency (18% means 18 points) for an over cost of 60%, or a 12% improvement for an overcost of 45% (called option b hereunder). These two indications dealing with full load improvement are consistent. We transform the first one into its marginal effect : a 7% improvement for a 15% overcost, called (a). Moving to multi speed control gives another 13% move for an over cost of 5%. We call (c) this improvement.

Starting from the reference model we obtain :

Table 7-3: LCC variations of ICV with different options

| LCC variations | Base case ICV | Base case ICV + a | Base case ICV+b | Base case ICV+a+b | Base case ICV+c | Base case ICV+a+c | Base case ICV+b+c | Base case ICV+a +b+c |
|--------------------------------|---------------|-------------------|-----------------|-------------------|-----------------|-------------------|-------------------|----------------------|
| General characteristics | | | | | | | | |
| Power W | 40,0 | 29,2 | 24,5 | 20,0 | 26,2 | 20,0 | 17,7 | 15,2 |
| Elec. KWh | 350,4 | 256,1 | 214,8 | 175,2 | 229,6 | 175,2 | 154,8 | 133,2 |
| LCC input (euros) | | | | | | | | |
| Price | 250 | 287,5 | 362,5 | 400 | 262,5 | 300 | 375 | 412,5 |
| Installation | 250 | 250 | 250 | 250 | 250 | 250 | 250 | 250 |
| Maint. 4% | - | - | - | - | - | - | - | - |
| LCC unit (euros) | | | | | | | | |
| Product price | 250 | 287,5 | 362,5 | 400 | 262,5 | 300 | 375 | 412,5 |
| Installation costs | 250 | 250 | 250 | 250 | 250 | 250 | 250 | 250 |

| | | | | | | | | |
|---------------------------|--------|--------|--------|--------|--------|-------|--------|--------|
| Electricity | 497,3 | 363,5 | 304,9 | 248,7 | 325,9 | 248,7 | 219,7 | 189,0 |
| Rep & maint. | 179,7 | 179,7 | 179,7 | 179,7 | 179,7 | 179,7 | 179,7 | 179,7 |
| TOTAL | 1177,0 | 1080,6 | 1097,0 | 1078,3 | 1018,0 | 978,3 | 1024,4 | 1031,2 |
| Elec / total ratio | 42% | 34% | 28% | 23% | 32% | 25% | 21% | 18% |

The benefit of option (c) is dominant but the present testing standard does not take part load control into account. We made before a suggestion for a part load efficiency index EEI_{PL}

7.4 Impacts of options on a DV-hood of average size

The inside parts of a hood are similar to the internal parts of an ICV. By introducing the generic change of motor and the changes considered in case studies 1 and 2 of ICV into the reference kitchen hood we can generate an approximate LCC curve. The over costs are directly extracted from the previous studies (generic& ICV). We call “Improved” hood the one with only the generic motor improvement, then a and b are the improvements of ICV.

Table 7-4: LCC variations of a hood with different options

| LCC variations | Base case HOOD | Imp Case HOOD | Imp case HOOD + a | Imp case HOOD+b | Imp case HOOD+a+b | | | |
|--------------------------------|-------------------|------------------|----------------------|--------------------|----------------------|--|--|--|
| General characteristics | | | | | | | | |
| Power W | 90,0 | 81,0 | 59,1 | 49,6 | 40,5 | | | |
| Elec. KWh | 66,0 | 60,0 | 43,8 | 36,8 | 30,0 | | | |
| LCC input (euros) | | | | | | | | |
| Price | 400 | 401 | 438,5 | 513,5 | 551 | | | |
| Installation | 250 | 250 | 250 | 250 | 250 | | | |
| Maint. 4% | - | - | - | - | - | | | |
| LCC unit (euros) | | | | | | | | |
| Product price | 400,0 | 401 | 438,5 | 513,5 | 551 | | | |
| Installation costs | 250,0 | 250 | 250 | 250 | 250 | | | |
| Electricity | 94 | 85 | 62 | 52 | 43 | | | |
| Rep & maint. | 0,0 | 0,0 | 0,0 | 0,0 | 0,0 | | | |
| TOTAL | 744 | 736 | 751 | 816 | 844 | | | |
| Elec / total ratio | 13% | 12% | 8% | 6% | 5% | | | |

7.5 Analysis LLCC and BAT for average product size

Ranking of the individual design options by LCC (e.g. option 1, option 2, option 3);

Determination/ estimation of possible positive or negative ('rebound') side effects of the individual design measures;

Estimating the accumulative improvement and cost effect of implementing the ranked options simultaneously (e.g. option 1, option 1+2, option 1+2+3, etc.), also taking into account the above side-effects;

Ranking of the accumulative design options, drawing of a LCC-curve (Y-axis= LLCC, X-axis= options) and identifying the Least Life Cycle Cost (LLCC) point and the point with the Best Available Technology (BAT).

LCC curve of a DV not hood

Figure 7-3: LCC curve of DV not hood

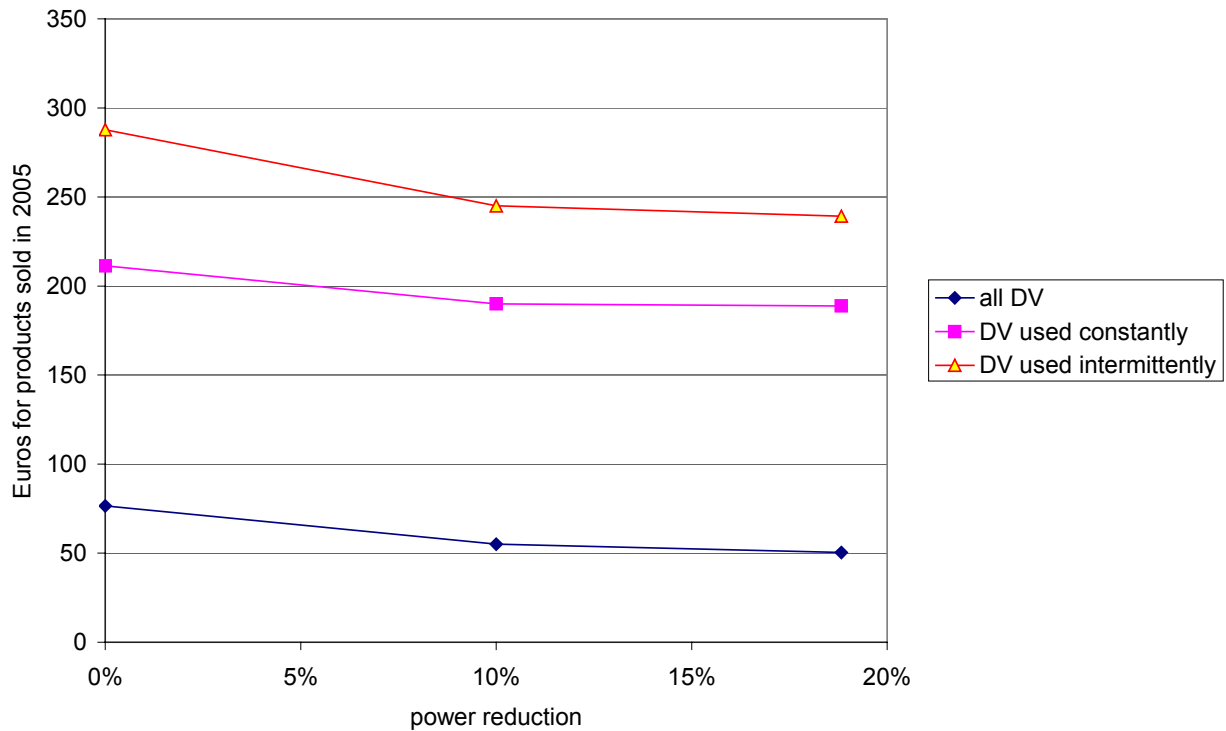

The products used continuously show a LLCC for a reduction in electricity demand between 10% and 20%. As the same products are used either continuously or not, we consider the market improvement should consider the weighted average of all products (line called : all DV). This leads to the same improvement, with the same LLCC. The value of BAT is very uncertain in this analysis. In any case the BAT EEI_{FL} more than 3 and would become more than 6 with a multi speed strategy.

LCC curve of an ICV of average size

Figure 7-4: LCC curve of an ICV with all options

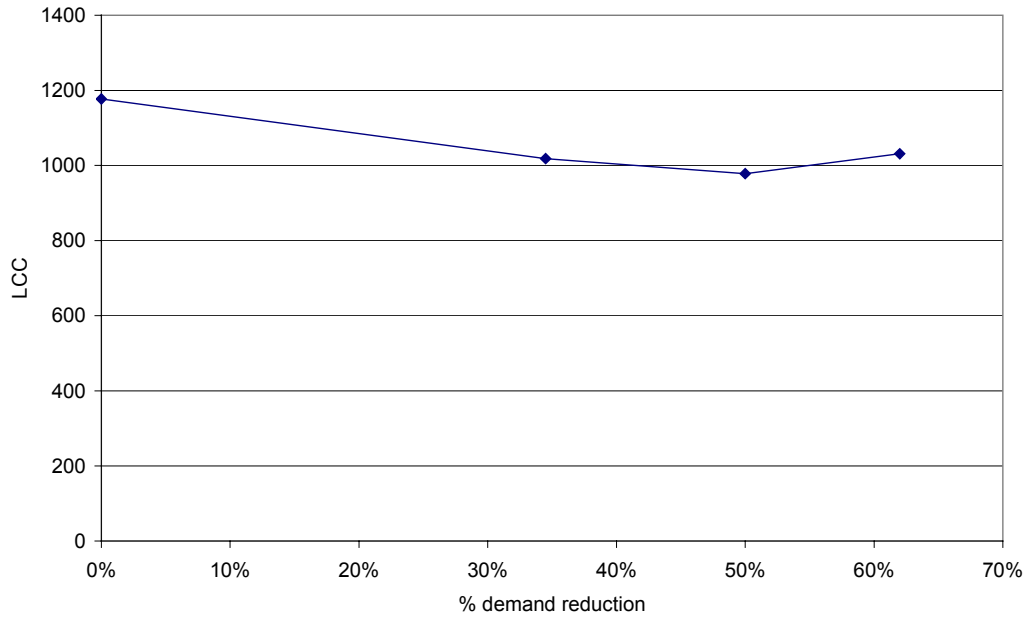

The reduction in total cost is limited but the energy gain is huge at LLCC (50%). The most profitable option adapts pressure to the demand, a freedom that some countries may not have. So we drew a LCC curve excluding this option.

Figure 7-5: LCC curve of an ICV if part load options are neglected

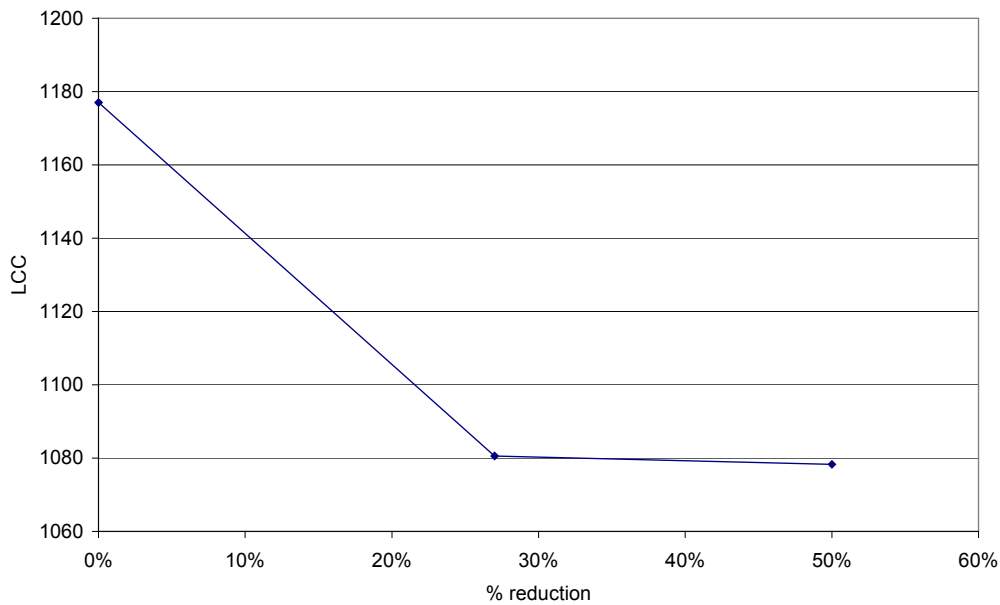

The optimum is flat but the 50% reduction is still optimal. A significant share of gains is due to flow reduction and should be measured at part load. The value of BAT at part load is between 30 and 45 and at LLCC around 25.

LCC curve of a DV hood of average size

Figure 7-6: LCC curve of a DV-hood

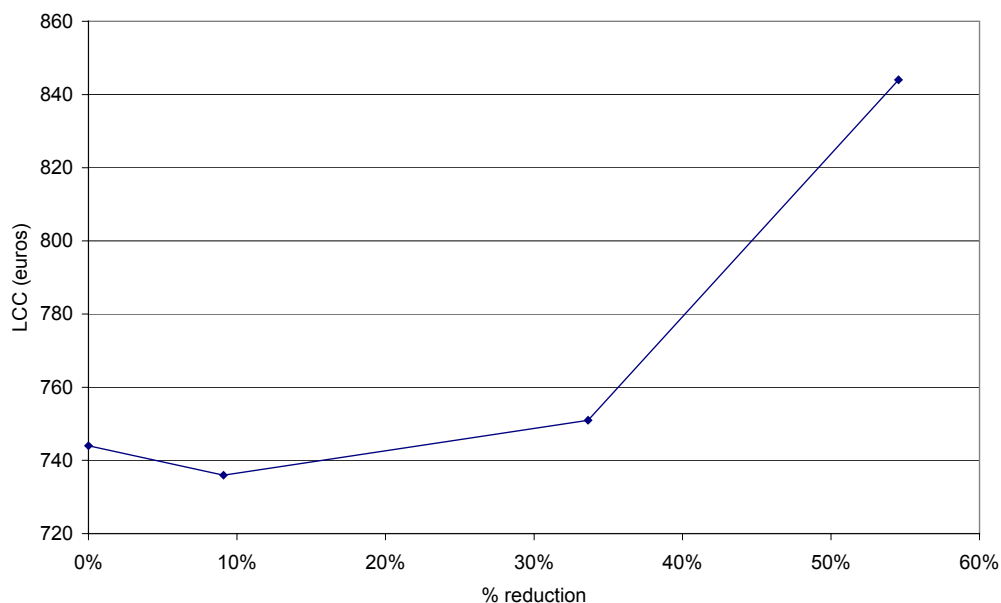

Savings are possible but they don't pay for themselves all with the present over costs values. The value of BAT is over 15 and the LLCC over 9.

7.6 Long-term targets (BNAT) and systems analysis

Discussion of long-term technical potential on the basis of outcomes of applied and fundamental research, but still in the context of the present product archetype

Discussion of long-term potential on the basis of changes of the total system to which the present archetype product belongs: Societal transitions, product-services substitution, dematerialisation, etc.

Hybrid ventilation

Passive stack natural ventilation can be stabilized by an hybrid fan. This small power fan can be designed not to create any additional pressure loss when stopped since its central blades are parallel with the airflow. So it allows the normal operation of the passive stack ventilation when the fan is off. This technology which is just starting to be deployed in some countries is not at all allowed in some other countries. The only question on which we can take position in this study is to decide if the scheme should be applied to those products. The product that we could study, despite being in the range of power of the DV, has the flow of an ICV (300 m³/h) and an efficiency far higher than other DVs. We conclude that their integration in the same scale as other fans, if it does not show all their benefits, will not disqualify them if the size effect in the assessment is expressed in terms of electrical power, not air flow rate.

Air purification

Air purification (odours, CO₂, H₂O) without real air change would be optimal for saving thermal energy but is not a BNAT for electricity consumption reduction. It is a BNAT for the thermal building regulations decided by MS.

The hood in recycling is an example of this thermal BNAT compared with the remainder of ventilation (it provides air cleaning without air rejection to the outside!) but CO₂ is not treated. Nobody is perfect.

BNAT based on demand control ventilation

The ultimate mechanical ventilation BNAT will supply natural air in a completely motorized way with sensors of IAQ and use of natural ventilation when possible. Let's start with the most ambitious vision before introducing some medium term options.

The most ambitious ventilation systems are based on demand-controlled hybrid (natural+mechanical) technologies. Reshyvent research project (www.reshyvent.htm) tries to combine natural ventilation and demand control. Within A Demand Controlled Hybrid Ventilation System is a two-mode system using natural forces as long as possible and electric fans only if necessary. Sensor technologies are used to establish the exact required air flow for indoor air quality and thermal comfort to a minimal energy demand. Within the Fifth Framework Programme of the European Commission a research project RESHYVENT has been started since January 2002.

The aim of the RESHYVENT project was to research, develop, and construct demand controlled hybrid ventilation concepts for residential buildings. The objectives were:

- * to integrate renewables and hybrid technologies in ventilation concepts
- * to determine the impact on GHG mitigation, energy use, IAQ, thermal comfort, noise, further application of renewables and use of low valued energy for heating and cooling
- * to define the parameters for controlling indoor air quality and thermal comfort
- * to give recommendations and proposals for national and international (CEN) standardisation of (advanced) ventilation systems
- * to develop measurement and control strategies for hybrid ventilation systems for different relevant EU climates (severe, cold, moderate, mild and warm)
- * to give specifications, guidelines and terms of references to develop demand controlled hybrid ventilation system including practical application guide and descriptions, suitable to be implemented in EU industries, easy accessible by ICT networks
- * to develop and construct four complete demand controlled hybrid ventilation systems covering four (severe, cold, moderate and mild/warm) European climates
- * to identify market chances, threats and barriers

The output of Reshyvent is not exactly known.

In the meanwhile there are some techniques routinely used in non residential ventilation like monitoring of agitation, presence, CO₂ that can be transferred to residential ventilation. Since they monitor closely the behaviour of people at home, it's unlikely that there is a large social acceptance.

Also the electronics can be used in an even more modest way : balancing the distribution of fresh air, while keeping the present user interface. At the maximum we have presently one pressure sensor that can be located at suction of fan or somewhere else in the network. One NABT would be to offer four or five sensors and actuators controlled centrally to balance the flow and reduce the speed as much as possible. The present level of reduction of flow that we called (g) is in fact limited by this lack of central knowledge and distributed actuation.

Task 7 summary

The penetration of BAT varies : some are used in some products and not in the others and this transfer of BAT from one family to another is already part of the optimisation potential. Improvements related with rotation speed can be used in the product but may be limited by the building codes which define pressure levels requested at lower flows. These improvements cannot have the same level of implementation as the full load improvements.

DV not hood show a LLCC for a reduction in electricity demand around 10%. As the same products are used either continuously or not, we consider the market improvement should consider the weighted average of all products. This leads to the same improvement objective, with the same LLCC. The range of total efficiencies (starting from 1%) can only be explained if the less efficient motor is used with an axial flow turbine (leading to 4-5% total efficiency) and that some design errors are made in some models.

Impacts of options on an ICV is important in energy terms. The reduction in total cost is limited but the energy gain is huge at LLCC (50%). The most profitable option adapts pressure to the demand, a freedom that some countries may not have.

By introducing the of options on a DV-hood having the 9% reference kitchen hood (the multi speed – option 3- is already generalized) we can generate an approximate LCC curve. Savings are possible but they don't pay for themselves with the present values (very uncertain however).

A testing procedure is summarized, based on chapter 4, that allows to give the benefit to all techniques used to reach the BAT.

The following rough summary of BAT and LLCC targets can be proposed:

| EEI at PL | “Local ventilation”=DV | « Hoods » | “Central ventilation”=ICV |
|------------------|-------------------------------|--------------------|----------------------------------|
| BAU | 2 | 6 | 12 |
| LLCC | 3 | 9 | 24 |
| BAT | >3 (estimated 4) | >15 (estimated 18) | >30 (estimated 38) |

About BNAT, the most promising is Passive stack natural ventilation can be stabilized by an hybrid fan. This small power fan can be designed not to create any additional pressure loss when stopped since its central blades are parallel with the airflow. So it allows the normal operation of the passive stack ventilation when the fan is off. This technology which is just starting to be deployed in some countries is not at all allowed in some other countries.

Air purification (odours, CO2, H2O) without real air change would be optimal for saving thermal energy but is not a BNAT for electricity consumption reduction. It is a BNAT for the thermal building regulations decided by MS.

8 SCENARIO-, POLICY-, IMPACT- AND SENSITIVITY ANALYSIS

Scope: This task summarizes and totals the outcomes of all previous tasks. It looks at suitable policy means to achieve the potential e.g. implementing LLCC as a minimum and BAT as a promotional target, using legislative or voluntary agreements, labelling and promotion. It draws up scenarios 1990 – 2020 quantifying the improvements that can be achieved vs. a Business-as-Usual scenario and compares the outcomes with EU environmental targets, the societal costs if the environmental impact reduction would have to be achieved in another way, etc.

It makes an estimate of the impact on consumers (purchasing power, societal costs) and industry (employment, profitability, competitiveness, investment level, etc.) as described in Appendix 2 of the Directive, explicitly describing and taking into account the typical design cycle (platform change) in a product sector. Finally, in a sensitivity analysis of the main parameters it studies the robustness of the outcome.

8.1 Preparation works for policies- and analysis of options

Preliminary discussion of the scope of the policy measures

Most categories of fans grouped under PRODCOM 29.71.15 are within the scope of the study. All fans without Heat Recovery in categories 29.71.15.33 (Roof ventilators), 29.71.15.35 (Other ventilators), 29.71.15.50 (Ventilating or recycling hoods incorporating a fan, with a maximum horizontal side ≤ 120 cm; this indication about size is not present in the other languages than English and is not a category limit; there is no category for larger hoods) were examined and found to be within the scope of potential ecodesign requirements. Among 29.71.15.30 (Table, floor, wall, window, ceiling or roof fans, with a self contained electric motor of an output ≤ 125 W) only roof fans are in the scope.

The power limit of 125W (not applicable to hoods) was agreed between lot 10 and lot 11 and corresponds both to PRODCOM coding and to the reality of the market for individual residences (as opposed to collective ones). There are occasionally individual products with a higher power demand but only for balanced supply and extract flow and the power associated with ventilation itself¹⁹ (one side, no heat recovery) remains under the 125W limit. Residential ventilation fans usually include the motor, as opposed to larger power fans, they are tested under specific standards (EN 13141 parts 4 and 6 and CEI/IEC 61 591) and provide lower pressure differences. Thus the distinction between the two groups of fans corresponds to strong technical differences.

The study looked in a quantitative manner at all phases of the lifecycle of the products: materials use, manufacturing, transport, distribution, installation and maintenance, use, end of life. The environmental impact of residential ventilation products is largely dominated by energy consumption. The electricity consumption represents from 13 % of the life cycle cost for the end-user for hoods, up to 88 % for Window and wall fans used continuously. Energy consumption in the use phase accounts for 73% of the Total Energy use, 100% of electricity use, 98% of Water (process) rejection, 100% of Water (cooling) rejection, 60% of Waste, non-hazardous going to landfill and 34% of Waste, hazardous to be incinerated are generated. Total impact for the stock of products in use in 2005 is of the same order of magnitude as for air conditioners but the stock and environmental impact growth rate is slower than for air conditioning appliances. Since there is a factor of 3 to 5 between the best and worst energy efficiency of residential ventilation products, there is significant potential for reducing energy consumption and CO₂ emissions if we target the electricity use of the products.

¹⁹ obtained as already said by dividing by 2 the total consumption

Only products with heat recovery (in the sense of testing standard EN 13141-7 and -9) are excluded from the scope since products with HR are under the 200 000 units sales limit, the interaction with EPBD national legislation is still uncertain and the testing standard is changing rapidly. It is suggested to return to this subject in a separate study when the number of sales reaches 200.000 pieces per year and when the testing standard has been revised. At that time the new study may consider other aspects of ventilation including HR systems, air quality, tertiary and industrial heat recovery (this has not been considered in lot 11) and other air preheating opportunities like solar panels and heat pumps. The new section -7 of EN 13141 should be stabilised before this study is launched and positive links with EPBD legislation should be part of the study since the potential improvements depends on other building design decisions.

The alternative geometric locations for installing a ‘local ventilation fan’ are typically categorized as :

- Roof fans (with Electrical power under 125 W) if it is designed to be situated on a roof
- Window fans (with Electrical power under 125 W) if it is designed to be installed in a window
- Wall fans (Elec power < 125 W) if it is designed to be installed in a wall.

Illustrations can be found in table 1-1, but despite these appearance differences, the products are in the same category of local ventilation in residences.

How many products are in the scope?

Residential ventilation fans, including hoods, (estimated at: 7.3 million units/year, of which more than 4 million hoods in ventilation mode²⁰, and 3.3 million local ventilation fans) and the central residential fans (estimated at 1.4 million units/year) are clearly above the EuP threshold of 200 000 products per year. The ventilation device with the largest penetration in Europe is the kitchen hood.

Stock of residential ventilation fans

An estimate of the stock of equipment in use has been made and adjusted to existing field data. It shows a large penetration of local ventilation fans (68 million units, including kitchen hoods connected to the outside) and central ventilation fans (18 million units). Nevertheless natural ventilation is the dominant means of providing ventilation. .

It is also to be noted that the environmental impact of residential ventilation products is largely dominated by collective ventilation, which accounts for about two thirds of all impacts - with an energy consumption of about 14 TWh in 2005 compared to over 21 TWh for the whole end-use of residential ventilation. However, the scope of the proposed measures has been limited here to individual products, under 125W, except for hoods which use a few hundreds Watt. Collective ventilation fans are within the scope of the Working Document of the Commission “Working document on possible ecodesign requirements for ventilation fans.” - continuity of ecodesign measures will be discussed later.

General issues for all three individual ventilation product groups

The proposal of having a common legislation is the first question. Obviously the possibilities for improved efficiencies are not the same and the duration of use is not the same. The service is not the same and somebody purchasing a hood should not think it will provide a full ventilation of the residence. So the EU should label or generate an obligation and a different name for each category. The scale for hoods should bear the name “**Hood**”, the scale for decentralized ventilation fans except hoods should be called “**Local ventilation**” (when there is only one spigot for air suction) and the scale for centralized ventilation should be called “**Central ventilation**” (multiple spigots or choice of the manufacturer). On the other hand **the three scales of labeling and obligations can be**

²⁰ and the rest in recycling mode but also covered by the proposed measures

developed jointly, by requiring the same levels of effort for each family taking into account their different duration of use, air flow, costs, etc.

Off-modes and standby electric consumption, are not generally present in ventilation products. Only kitchen hoods have them and there is no reason not to apply the general rule defined by lot 6 to a kitchen hood, (which is not generally the only ventilation system in a kitchen). Other ventilation products in residences are either permanently in use (because there is a permanent need to eliminate moisture) or controlled by an on/off switch (with no off-mode electricity demand): they can be excluded from the field of application of lot 6 to avoid any misinterpretation of lot 6 measures. The minimum flow at 25% in testing avoids condensation and mould and a testing point at 0% flow would have no meaning. **On the other hand, when there is an integral air quality sensor (sensing for example H2O or CO2) that controls operation (either analog or digital, manual speed selection by user) its standby consumption is included in the testing process but not regulated by the measures deriving from lot 6. When there is a remote controller, standby consumption inside the product should be measured and regulated as in lot 6.**

In other words, ventilation products (except hoods) cannot have such low standby consumptions as other products when it is part of their duty to permanently energise sensors detecting a need for air change, and to maintain a small flow to reduce the impact of moisture and other pollutants. Except for kitchen hoods and remote controls, standby consumption for sensors and controllers is included in the testing process, not excluded and regulated separately. In describing the four tests the testing annex included in the present chapter **mentions this inclusion of standby, sensors & controls in the overall consumption.**

Specific issues of kitchen hoods

First specific problem : the choice of the speed for end user information. Several speeds are usually available, very often three. The testing standard is often applied at speed N-1 (where N is the highest speed) for energy use (usually speed 2 if there are three speeds) and also for acoustics (speed 2 is thus designed by the manufacturers to be good in noise), rather than providing the end user aware of performance at the higher speed often described as "booster speed", or "intensive". Air flow may be reported at speed N. In practice, it may well be that the highest speed is the one most often used, in which case sound level, air flow efficiency and efficiency for that same highest speed should serve as a basis for end user information.

The only limitation to overpower of hoods is the noise that they may generate. A flow of 300 m³/h is sufficient technically but the customer appreciates overpower. It goes up to 1 000 m³/h. One thus goes from 5 ACH²¹ to 20 ACH, which is not good for electricity use but even worse for thermal energy use. Without suppressing the possibility to have such high flows, the fact of documenting the highest flow rate (speed N) and not the following one (speed N-1, usually 2 out of three) for both the noise and electrical effectiveness seems the best choice for consumer information.

Finally it is essential that in labeling an appliance all information should be consistent, i.e. corresponding to the same situation, in this case the same speed, in the study proposal the highest speed (the real highest, even if called booster). However if an automatic timer or sensor brings back the hood to another speed in less than 2 minutes, the highest speed could be considered as this speed and the other (upper) speeds as real boosters, not suitable for end user information.

Second problem. The hood has another function of importance: **illumination of the working area.** Lighting is very well treated in the testing standard and some manufacturers are making real efforts to

²¹ ACH is the ratio of the air flow to the volume of the room; a value like 1 or three is frequent; however for kitchen hoods the service expected is a quick removal of grease and odour, leading to higher necessities.

move from 2 x 40W (Incandescent), 2 x 20 W (halogens LV), 2 x 3 W (LED) and to treat the luminaires in such a way as to have a very good level of illumination on the working plane. This effort is really ecodesign dealing with lighting and could be put on the same level as other efforts concerning this EuP. However it belongs to the Lot dealing with lighting and has to be validated within that framework. The proposal of some stakeholders is to include the information (already available in the testing standard) on an EU label of the usual type, as done in the past for some other information. The value would be a high level information that can be obtained from the existing testing standard in lux/watt. **The evidence of potential gains support this introduction if made in a suitable technical way, not lower than the “general lighting” ecodesign requirements.**

Third problem : the grease filter effectiveness is variable from one product to another, leading to variable pressure drop if the filter is left in place, reducing the apparent performance of products with better filtering compared with those with poor filters. The technical study considered the scenario of removing the filter during testing but it seems preferable to leave the grease filter in place for the test as in the testing standard (-1 to +1 % of efficiency, too complicated to correct). Also all the directories (thousands of models) are based on having the grease filter in place.

Fourth problem : should the requirements make a distinction between the four geometries of kitchen hoods (see figure 1-5), which can be seen as distinct from outside? The “bottom-of-the-market” hoods (“under cabinet”) are less efficient for two reasons: the plane geometry of the fan and the intensity of price-based competition between manufacturers. The flat rotor has only one entry point and uses blade surface badly. A larger rotor with a motor in the middle and two inlets would have a better efficiency. However, there is no room for such a rotor in some very thin under-cabinet hoods. Evidence suggests that they can nevertheless go up to the level of performance of integrated hoods, which have similar geometry. Basically the reasons for present poor efficiency is really that the competition on this range of entry products is only based on the lowest possible cost, a factor that information can correct. **Evidence suggests that no distinction should be made between the four types of hoods. They correspond to four design styles of the kitchen with some implications on energy performance, but these are of a marginal importance.**

Is there a need for a specific definition of ‘full load’ for kitchen hoods? The IEC standard considers the “highest speed” but there is an agreement among manufacturers to consider that the highest speed is not the ‘booster’ mode, but the speed below. The proposed requirements are based on the real highest speed. It is necessary that kitchen hood manufacturers accept that end user information should be based on the highest speed, even if the existing directories are based on a lower speed. Obviously if the highest speed is really a “booster” coupled with a quick timer, the highest speed cannot be considered as the other ones.

The proposal made by some manufacturers²² relating to information about lighting integrated in kitchen hoods is independent of the speed and can be accepted immediately after consistency checks with the “general lighting” measures. This should not avoid the need to satisfy any more “general lighting” requirements.

Discussion of possible labeling or grading structures

Grading of performance (which product is better and how large the difference is) is based on the BEP (Best Efficiency Point) of the characteristic line and associated reduced speed points (part load) in the proposal. **This leaves to MS their freedom of choice of pressure and flow requests.** It allows a comparison of products, independently from national regulations and habits, and will ease the comparison of products. One can consider that the new possibility of comparing products adapted to different national markets will lead some MS to complement the free circulation of ventilation

²² Posting the lux/watt ratio in the conditions of the testing standard, averaged over the four measurement points of the IEC standard

products by a reminder about their national demands on the minimum air quality or a minimum flow or a minimum pressure that some countries demand, as we have seen already many examples in place.

Some may think that the first phase of labeling can only be based on **full load**, because of the significantly different national levels of market control in ventilation, of the lack of information and of the diverging national habits. **However a large share of gains (corresponding to the LLCC) is associated with the adaptation of the speed to the needs.** So it would be more consistent to start immediately the labeling on the basis of a part load index, with a simplifying assumption for the manufacturers and countries which have not started their evolution towards modulating products. A simplifying assumption has been proposed in the annex 8.5, included in the present chapter. After a few years of part load labeling where some manufacturers will take advantage of the simplified procedure because they are not technically ready to have four test speeds (25%, 50%, 75% and 100% of the flow at BEP) instead of one, one can expect that the proposal made in the annex included in the present chapter becomes a practical standard for part load testing and substitutes full load indices.

The simplifying assumption during the adaptation period is the following. If the equipment realizing ventilation has only one speed, or if one manufacturer does not want to measure its performance at part load as proposed, the part load Energy Efficiency index can be computed as being half of the full load Energy Efficiency Index (which is the efficiency at BEP multiplied by 100 and rounded to the closest integer)

How to generate consistent grading scales (for labeling or performance requirements) for different sizes of ventilation fans? There may be a correspondence between the three grading scales not visible for the final user but guaranteeing the sharing of efforts between the various professionals. There is a size effect limiting the possibilities to improve small fans but a wider range of improvements is possible in larger equipment. The pressure to be put on a certain segment of ventilation can be correlated to the electricity demand at the BEP times the duration of use during the year. If one considers for instance that one frontier between letters in a classic EU labeling system could be based on the average EEI@PL (set as the border between E and F), figure 8-1 shows a good consistency. It is based on table 5.1 with the adequate weighting for local fans intermittency assumed in part 2.2 (14/15). The larger consuming products have already been more improved and will be labeled according to their energy consumption importance by using consistent classes.

Figure 8-1: Comparison of the average EEI @ PL values (three points displaying the EEI of 2, 6 and 12 for the average size product) and energy consumption of products showing some consistency and leaving room for two classes of grading under average (the red line indicates the E/F border set at average value); DV means local ventilation, ICV means central ventilation here

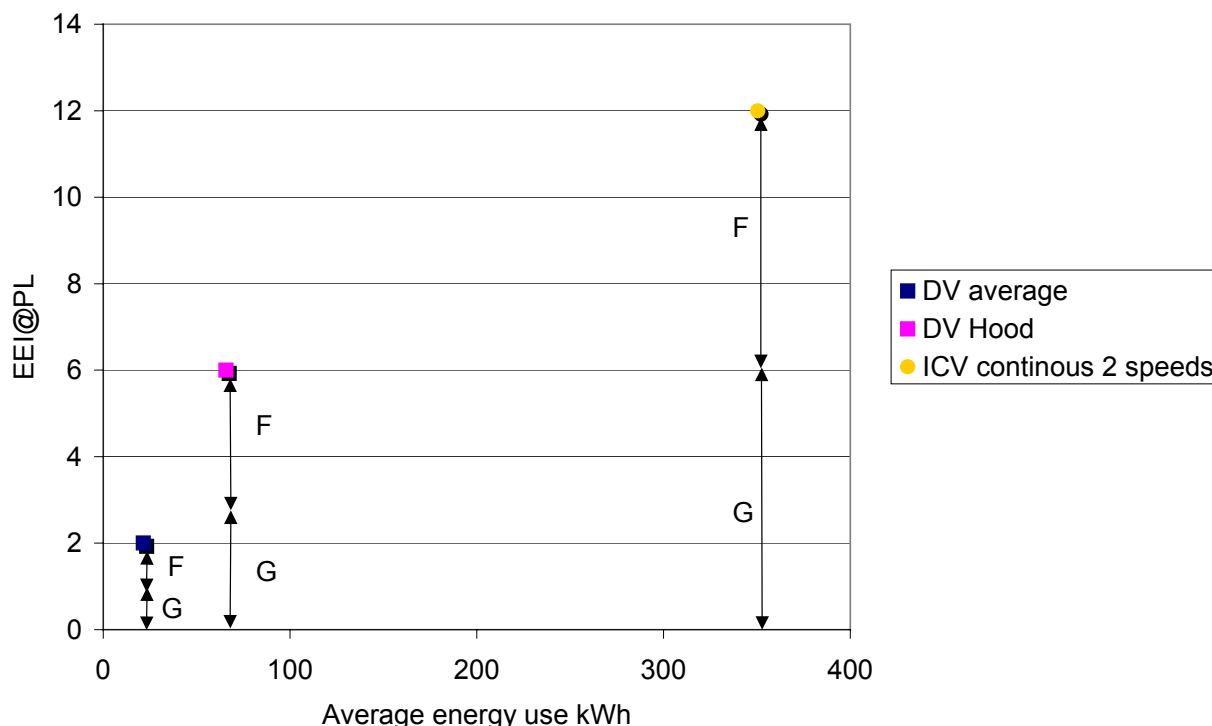

Next question : what is the extent of the range of grading? There is only room for two classes (F and G) between zero and the average EEI if we stay with rounded figures, and the study has shown that the EEI of the BAT is far above the present EEI average values. So it's logical to define five classes between average and BAT, and two classes under present average.

Some manufacturers are afraid of the introduction of energy performance classes in which only one manufacturer appears immediately in top class. The problem is solved by making an empty class A based on the BAT which solves this problem of unfair competition (one cannot give A to only one manufacturer at the starting point). The proposal creates fair competition for the first “class A” equipment on the market.

These two considerations lead us to propose the following scheme in table 8.1:

Table 8-1: Efficiency classes proposed for consistency of grading of residential ventilation fans based on EEI at Part Load (the EEI is shown for the average size product)

| Classes | “Local ventilation” of average size, non cent. P = 17W | « Hood » of average size = 150W | “Central ventilation” of average size = 75W |
|---------------------------|--|---------------------------------|---|
| Reminder: value of BAT | 4 (more than 3) | 18 (more than 15) | 38 (more than 30) |
| “Highest” or A | EEI@PL>6 | EEI@PL>18 | EEI@ PL >38 |
| B | 6>=EEI@PL>5 | 18>=EEI@PL>15 | 38>=EEI@PL>31 |
| C | 5>=EEI@PL>4 | 15>=EEI@PL>12 | 31>=EEI@PL>24 |
| LLCC or D | 4>=EEI@PL>3 | 12>=EEI@PL>9 | 24>=EEI@PL>17 |
| “Just above average” or E | 3>=EEI@PL>2 | 9>=EEI@PL>6 | 17>=EEI@PL>12 |
| F | 2>=EEI@PL>1 | 6>=EEI@PL>3 | 12>=EEI@PL>6 |
| “Lowest” or G | EEI@PL=0 or 1 | 3>=EEI@PL | 6>=EEI@PL |

The grading scale has a wide extent, with an empty class A, and there is no reason to forecast any change in it before 2015, at the soonest.

Any label for hoods should bear the name **“Hood”**, any label for decentralized ventilation fans except hoods should bear the name **“Local ventilation”** and the label for centralized ventilation should bear the name **“Central ventilation”**. This is necessary to avoid that the end user or purchaser thinks the three products can generate the same air quality or treat the same area of dwelling. However going further in characterizing the two aspects (air quality, area ventilated) and obtaining a single labeling scale would put us in contradiction with some MS building codes.

What else should the label indicate? In order to guard against over sizing, the indication of the flow and the deltaP for which the BEP at Full Load has been obtained is a helpful information. The nominal electric power demand is basic information that should be given to the end user. Noise level is also an important indication, even if the final acoustic impact depends more on the capacities of the installer to use good ducts, dampers, intermediate sound trap than on the acoustic source itself.

To ease introduction of the scheme, there is the simple rule allowing the immediate application of the labeling scale if manufacturers don't want to take advantage of the part load test: EEI@PL can be taken as half of EEI @ FL as a default.

Discussion of immediate possibilities of MEPS

An immediate MEPS in ventilation cannot be Part Load in the present situation of MS regulations (because the building codes can impose to keep some pressure level at part load) and of lack of efficiency reporting. It should be a Full load based MEPS for some time, called MEPS@FL. This temporary difference between a MEPS based on full load and a labeling system based on weighted part load is not a big problem since the two tools have different objectives: transforming the market in the case of labeling, stopping products poorly designed at full load in the case of MEPS²³. A **“Local ventilation” product of average size with an EEI @ PL under 2 is far under the LLCC, as well as a «Hood» of average size under 8 at PL and a “Central ventilation” product of average size under 12 at PL. The full load MEPS@FL is then established at the same limit, in order that no product is banned by MEPS1 and allowed by MEPS2²⁴. The second MEPS will later (2012?) be based on Part Load, that will be at that time usual practice, and will ban at that time the products far under the LLCC. It will be called here MEPS@PL.**

Correction factor for size

The limits that have been outlined for the product of average size studied in previous chapters have now to be applied to a product of any capacity between 0 and 125 W. A linear relationship is found suitable with a distinct slope for centrifugal products on one hand (Central ventilation and hoods) and local ventilation products on the other hand (a mix of axial, centrifugal, with or without vanes) as shown on figure 8-2 hereunder.

Figure 8-2: Correction for size of the real product, to be applied to the average product

²³ and the translation by $EEI@PL = EEI@FL / 2$ is immediate, even if penalising for products with a good control

²⁴ EEI usually decreases when moving from FL testing to PL testing

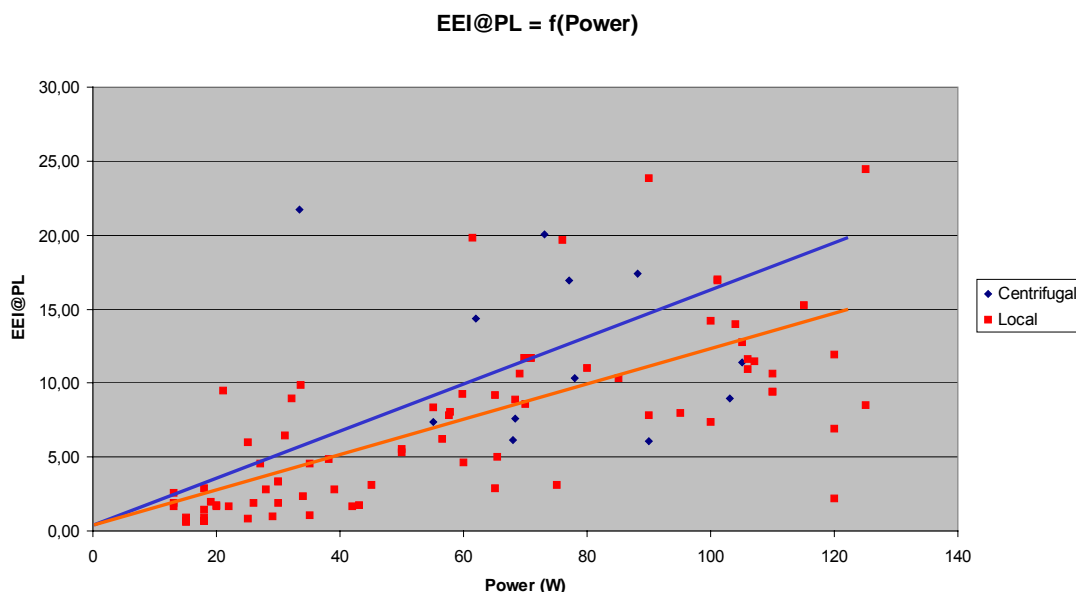

The two dependencies are different. The slope has been found to be 16.47 W^{-1} in the case of central ventilation and hoods and 12.07 Watt^{-1} in the case of local ventilation products. Consequently all limits are made proportional to the nominal P. The version of the previously defined grading structure applicable to any product size is given in table 8-2.

Table 8-2: Efficiency classes proposed for consistency of grading of residential ventilation fans based on EEI at Part Load (the product EEI is rounded to the closest integer)

| Classes | “Local ventilation” of nominal Power P | « Hood » of nominal Power P | “Central ventilation” of nominal Power P |
|---------------------------|--|---|--|
| “Highest” or A | $EEI@PL > 6 * P / 17$ | $EEI@PL > 18 * P / 150$ | $EEI@PL > 38 * P / 75$ |
| B | $6 * P / 17 \geq EEI@PL > 5 * P / 17$ | $18 * P / 150 \geq EEI@PL > 15 * P / 150$ | $38 * P / 75 \geq EEI@PL > 31 * P / 75$ |
| C | $5 * P / 17 \geq EEI@PL > 4 * P / 17$ | $15 * P / 150 \geq EEI@PL > 12 * P / 150$ | $31 * P / 75 \geq EEI@PL > 24 * P / 75$ |
| LLCC or D | $4 * P / 17 \geq EEI@PL > 3 * P / 17$ | $12 * P / 150 \geq EEI@PL > 9 * P / 150$ | $24 * P / 75 \geq EEI@PL > 17 * P / 75$ |
| “Just above average” or E | $3 * P / 17 \geq EEI@PL > 2 * P / 17$ | $9 * P / 150 \geq EEI@PL > 6 * P / 150$ | $17 * P / 75 \geq EEI@PL > 12 * P / 75$ |
| F | $2 * P / 17 \geq EEI@PL > 1 * P / 17$ | $6 * P / 150 \geq EEI@PL > 3 * P / 150$ | $12 * P / 75 \geq EEI@PL > 6 * P / 75$ |
| “Lowest” or G | $EEI@PL \leq 1 * P / 17$ | $3 * P / 150 \geq EEI@PL$ | $6 * P / 75 \geq EEI@PL$ |

For example, the size dependant version of “EEI @ PL under 2” (local) is “EEI @ PL under $2 * P / 17$ ” (17 being the nominal power of the non centrifugal local ventilation device studied in details), as well as “EEI @ PL under 8” (hoods) is “EEI @ PL under $8 * P / 150$ ” and “EEI @ PL under 12” (Central ventilation) is “EEI @ PL under $12 * P / 75$ ”. The full load MEPS@FL limits are the same, as already stated.

8.2 Ecodesign requirements

Introduction of ecodesign requirements

Let’s call Y_0 the date of publication of the ecodesign measure (taken as 2009 in the impact study). A first set of documentation requirements part of scenario1 will be applicable two years later. Labelling

and MEPS@FL (at Full Load) will take place after three years and constitute the essential of scenario 1. Then Scenario 2 introduces MEPS@PL 6 years after publication. Those delays are mostly related with the time needed to adapt directories and documentations, and partly to changes of technology (the technologies needed being largely available).

Definitions, link with Prodcum, link with testing standards

A fan is a rotary bladed machine that is used to maintain a flow of a gas, typically air, and which is driven by an electric motor. The ventilation fans are encased. The products considered here have been designed for use in one single dwelling or one room of the dwelling or the cooking zone of a kitchen. There are three categories of residential fans covered by the potential requirements and the design options : local ventilation fans, kitchen hoods, central ventilation fans. The “hoods” are easily identified as such by the manufacturer but for the other products the manufacturer or the laboratory has to determine if the product belongs to “Local ventilation” (when there is only one spigot or terminal device) or “Central ventilation” (various spigots or terminal devices in the product as sold or manufacturers decision).

A '**residential ventilation fan**' is any fan that are designed to move air from or into a residential building. This definition is consistent with Prodcum and CEN categories, as of year 2007. EN 13141 in its general title speaks of components/products for residential ventilation and parts 4 and 6 serve as a basis for the characterization of the products in the scope. PRODCOM categories 29.71.15.33 (Roof ventilators) and 29.71.15.35 (Other ventilators) with an electrical input under 125W are “residential ventilation fans”. Those fans in PRODCOM category 29.71.15.30 (Table, floor, wall, window, ceiling or roof fans, with a self contained electric motor of an output ≤ 125 W) are “residential ventilation fans”. Among residential ventilation fans there are two categories.

The study proposes three residential ventilation fan categories as follows:

A '**residential kitchen hood**' incorporates a fan providing local ventilation or recycling of air in a kitchen. This is stated in PRODCOM 29.71.15.50. A 'residential kitchen hood' can be tested under CEI/IEC 61 591: 2005.

A '**local ventilation fan**' is any other fan providing local ventilation and designed to serve only one room and consequently having only one spigot related with the inside of the building. It is in the scope of the ecodesign measures when it has an Electrical power under 125 W. Part 4 of EN 13141, as of year 2007, names them encased ventilation fans.

A '**central ventilation fan**' is a type of residential ventilation fan designed to serve various rooms and consequently has various spigots related with the inside of the building or is sold with components that allow to connect with various terminal devices inside the rooms. A manufacturer can declare as “central ventilation fan” an equipment that has only one spigot but has been designed to serve various rooms by using other components to do so, and consequently shall apply in that case the (more demanding) limits. It is in the scope of the ecodesign measures when it has an Electrical power under 125 W. Part 6 of EN 13141, as of year 2007, covers Exhaust ventilation system packages used in a single dwelling, but the scope includes products which move air from outside to inside, and not only exhaust.

There is no power limit on ‘residential kitchen hoods’ for them to be in the scope, but there are many products in the range between 100 and 300W . Hoods used as a ventilation mean are part of residential ventilation fans but the proposed requirements apply also to hoods used in recycling mode (no ducting to outside) because it’s the same product: the decision on how to use the hood is made by the final user and the energy and resources use is the same in both situations, as well as the improvement possibilities.

Those definitions were selected instead of more technical descriptions of the equipment features inside or outside (which are available in chapter 1) because it's a B to C product for which labeling has a meaning (as opposed to larger fans) : there should be a relatively clear functional cut that the consumer can understand (three categories). This proposal is consistent with the three testing standards and promotes competition for the selection of the most efficient technique to provide a function.

Exclusion

The products excluded from the scope of the proposed design options are: comfort fans (which move the air inside the room, not in relation with outside) that have been subject to a parallel study, all ventilation products with heat recovery, mostly due to market size, but also to potential interaction with national EPBD legislation and ongoing testing standard revision, fans integrated into a boiler, fans used for smoke extraction in case of fire.

Testing

EU industry has good testing standards at full load for products in the scope of the proposed requirements, on which are based the full and part load Energy Efficiency Indices used in the recommendations.

The existing (in year 2007) EN 13141, Ventilation for buildings - Performance testing of components/products for residential ventilation, namely Parts 4 and 6, is consistent with the proposed categories of 'residential ventilation'.

The existing CEI/IEC 61 591: 2005 called "test standard for household range hoods" applies to kitchen hoods, and there is a reasonable consistence with the other ventilation products testing standards, in terms of definition of characteristic line. However the standard covers many more aspects than the fan electricity consumption; which are useful for energy efficiency :

- It determines also the effectiveness of the hob light, and this information is a real high value ratio of the output (illumination on the work plan) to the electricity consumption for lighting (including the source, the luminaire, the position of sources
- And the noise;
- As well as other non energy parameters like grease filtering efficiency.

Both standards allow the determination of the characteristic line from which one extracts the Best Efficiency Point. The efficiency at BEP multiplied by 100 gives the Energy Efficiency Index at Full Load (EEI @ FL).

When there are various speeds, there are various characteristic lines and an adequate weighting allows to determine an EEI @ PL (Part Load). Part 8.5 explains how to perform this, in the absence of an harmonized standard for the purpose (this text is proposed to become an annex of any measure). The EEI @ PL will be the basis of most proposed measures, even if it is sometimes estimated initially with a simplified procedure from the full load equivalent because it is the index that allows representing a large share of environmental gains. The transformation of the Annex included in the present chapter into an EN standard is necessary for any policy taking effect in 2015 and after and deserving a higher harmonization between MS about ventilation. It is proposed that the Member State test laboratories and notified body use in the meanwhile the Annex included in the present chapter to characterize the products. They should be helped by some accompanying measures (described hereunder) to reach rapidly a sufficient number of tests so as to make the best out of the proposed procedure.

Ecodesign requirements related with energy use

Scenario 1: full load MEPS@FL and part load labelling A-G ; even if no other policy is yet applicable, it is important that the essential information of EEI @ FL and EEI@PL is made available rapidly to the end user at the time of purchase (either direct purchase or through an installer). An

accompanying measure to help reaching this level of information in the web of SME producing the ventilation products seems necessary and will be described later. Then the rest of the policy is introduced.

The proposal for scenario 1 is made of six requirements:

Requirement 1: “Every product in the scope of the measure shall bear on its plate the three values: *P* (Electrical demand at Best Efficiency Point at Full Load), *EEI* (Energy Efficiency Index) at Full Load, *EEI* at Part Load (weighted average of 25%-50%-75%-100%) determined as described in the technical annex included in the present chapter, starting from Y_0+1 .”

Also the specific standby and off modes are regulated as follows:

Requirement 2: “Standby requirements developed on the basis of the Ecodesign Lot 6 preparatory study apply to all kitchen hoods and to local (and central) ventilation products controlled by a remote controller, and only to the standby generated by the remote controller if any. Local and central ventilation products without remote controllers are excluded from Lot 6 standby preparatory study requirements due to the specific function of residential ventilation that requires a minimum flow and may use sensors to control it.”

Requirement 3: No product will be put on the market if it is a ‘Local ventilation’ product with an *EEI* @ FL under 0,1176**P*, as well as if it is a ‘Hood’ under 0,0400**P* at FL or a ‘Central ventilation’ product under 0,1600**P* at FL. This is MEPS@ FL, which is dependant on the electrical power absorbed *P*. The application of this measure starts at Y_0+3 . A manufacturer can declare as “central ventilation” an equipment that has only one spigot but has been designed to serve various rooms by using other components to do so, and consequently shall apply the (more demanding) limits.”

The labelling requirement may have an autonomous impact and is needed to prepare the further MEPS@PL. Due to the market structure (SME offering complete products) and to the type of appliance (size large enough, with a market accessible to end users and not only to installers) the existing A-G label is adequate. Both the label and the MEPS@FL shall be put in place in three years.

Requirement 4: “The efficiency class of the product for energy labelling shall be determined by the manufacturer on the basis of *EEI* at Part Load and electric power demanded at Full Load (called *P*, in Watt). A manufacturer can declare as “central ventilation fan” a piece of equipment that has only one spigot but has been designed to serve various rooms by using other components to do so, and consequently shall apply the (more demanding) limits. The determination is made with the following table.

| Class | “Local ventilation” | « Hoods » | “Central ventilation” |
|--------------------------------|---------------------------------------|---------------------------------------|---------------------------------------|
| A | $EEI@PL > 0,3529 * P$ | $EEI@PL > 0,1200 * P$ | $EEI@PL > 0,5067 * P$ |
| B | $0,3529 * P \geq EEI@PL > 0,2941 * P$ | $0,1200 * P \geq EEI@PL > 0,1000 * P$ | $0,5067 * P \geq EEI@PL > 0,4133 * P$ |
| C | $0,2941 * P \geq EEI@PL > 0,2353 * P$ | $0,1000 * P \geq EEI@PL > 0,0800 * P$ | $0,4133 * P \geq EEI@PL > 0,3200 * P$ |
| D | $0,2353 * P \geq EEI@PL > 0,1765 * P$ | $0,0800 * P \geq EEI@PL > 0,0600 * P$ | $0,3200 * P \geq EEI@PL > 0,2267 * P$ |
| E | $0,1765 * P \geq EEI@PL > 0,1176 * P$ | $0,0600 * P \geq EEI@PL > 0,0400 * P$ | $0,2267 * P \geq EEI@PL > 0,1600 * P$ |
| F (to be banned under MEPS@PL) | $0,1176 * P \geq EEI@PL > 0,0588 * P$ | $0,0400 * P \geq EEI@PL > 0,0200 * P$ | $0,1600 * P \geq EEI@PL > 0,0800 * P$ |
| G (to be banned under MEPS@PL) | $0,0588 * P \geq EEI@PL$ | $0,0200 * P \geq EEI@PL$ | $0,0800 * P \geq EEI@PL$ |

Requirement 5: The energy label will be displayed on the product with the format out of the three following formats corresponding to its category. As heading, the label for hoods should bear the name “hood”, the label for decentralized ventilation fans except hoods should bear the name “Local ventilation” and the label for centralized ventilation should bear the name “Central ventilation”.

All labels shall receive the noise information according to standard EN 13141 for Local ventilation and central ventilation and to standards IEC 61591&60704 for hoods, and indicate to the end user the flow in m³/h for which the product is optimal and the electric power absorbed in Watt, all this at the highest speed.

The hoods shall receive on the same EU label the value of illumination efficacy that can be obtained from the existing testing standard IEC 61591 and directly expressed in lux/Watt. It is the average luminance over the four points of the testing standard divided by the power input for lighting, in the highest conditions of lighting. This does not change any of the “general lighting” ecodesign requirements.

The label for hoods shall receive also the information on the efficiency of the grease filter given by IEC 61591, independently from the energy information.

When the energy label is used the information of requirement 1 can disappear from the plate.

The lay out of the labels shall be the following :

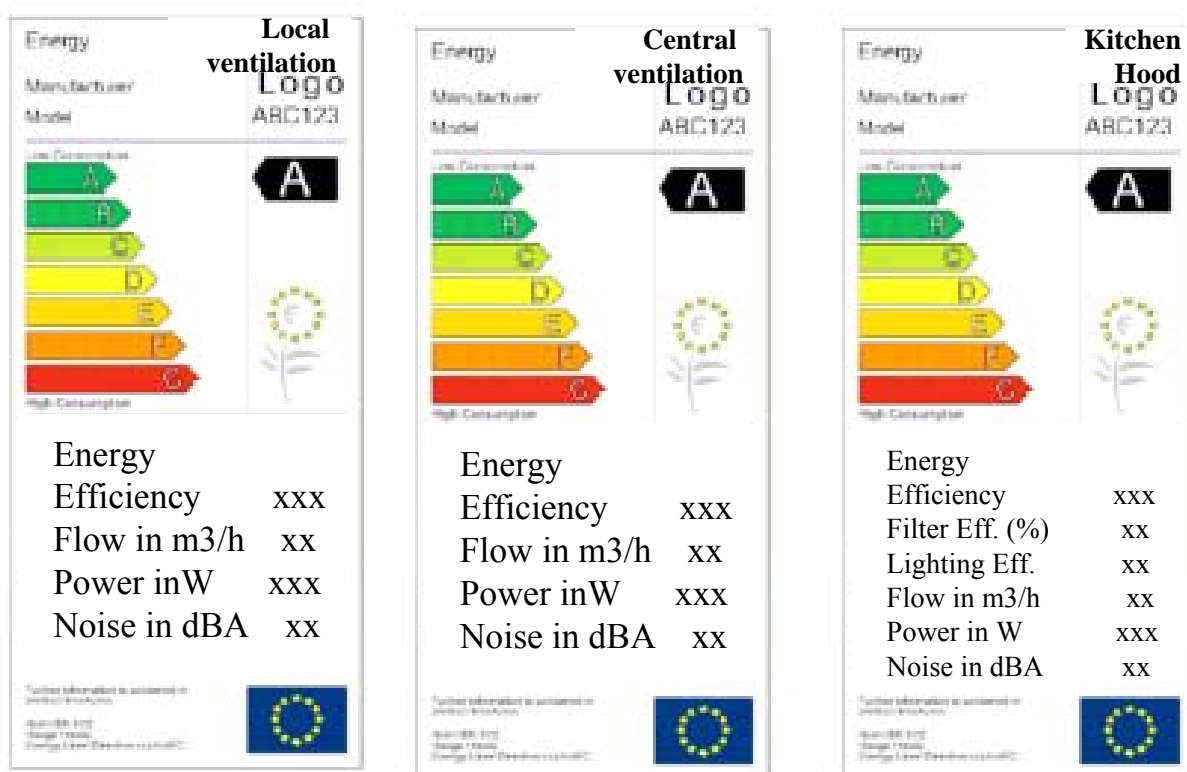

Requirement 6: As part of documentation available with the product in the MS language a fiche will represent the four characteristic lines used in determining the EEI@PL and the information requested under part 3 of Annex I of the Directive. The fiche will explain full and part load, at least with the following sentences:

‘It is important that you take advantage of the control options of your ventilation. It may operate continuously and adapt to conditions. It may offer various speeds among which you have to choose the lowest possible that maintains a good quality of your interior air. EEI@PL (Energy Efficiency at Part Load) has been used here to indicate how this equipment can be efficient when using the control options offered. All EEI are on a scale from 0 to 100. The characteristic lines of the four (or less) speeds that have been used in computing EEI@PL are given hereunder. These lines allow to realize respectively 100%, 75%, 50% and 25% of the flow rate for which this product performs optimally at full speed.’. This information will be given before the four lines and can be completed by the description of the specific control features of the product. An exact reference to the test standard section will be in the product documentation (for instance : tested according to EN13141-4). All numerical values available on the label will be available as well on the fiche for further retrieval.

The application of this measure starts at Y_0+2 .”

When the manufacturer does not want to perform part load testing, a simple default rule allows to estimate this EEI from the full load equivalent. The testing procedure and the simple rule are given in the annex 8.5 (annex to chapter 8 here).

For balanced flow products without heat recovery the electrical power is divided by 2 and the measure is applicable.

Scenario 2: proposed MEPS@PL levels on top of scenario 1.

When conditions have been obtained to base the product policy on part load EEI, there is room for a second MEPS level based on part load performance for a date three years later i.e. Y_0+6 (suppressing G and F), then further steps (suppressing E, etc.) in the following years.

Requirement 7: *“No product will be put on the market if it is a ‘Local ventilation’ product with an EEI @ PL under $0,1176 \cdot P$, as well as if it is a ‘Hood’ under $0,0400 \cdot P$ at PL or a ‘Central ventilation’ product under $0,1600 \cdot P$ at PL, where P is the electrical power absorbed. A manufacturer can declare as “central ventilation fan” an equipment that has only one spigot but has been designed to serve various rooms by using other components to do so, and consequently shall apply the (more demanding) limits The application of this measure starts at Y_0+6 .”*

General view of evolution and prospects

Unfortunately in some situations, the simplest way of increasing performance is to increase the flow: there is also pressure to set limits on noise in order to avoid solutions that the market will not accept. Since noise information is not available usually in directories, except for hoods (but then not for the highest speed), the MEPS on noise will be defined later, but not after MEPS@PL entry into force.

The other successive MEPS@PL –not described here- could lead to BAT (category A in grading) in 2015, provided there is a technical evolution leading to cost reduction for the necessary options.

Figure 8-3 provides a full picture on proposed measures: label, MEPS@FL, MEPS@PL, leading eventually to LLCC, based on the average product size. Table 8.3 summarises the same information.

Table 8-3: Date of measures if $Y_0=2009$

| Year | 2010 | 2011 | 2012 | 2015 |
|------------|---------------|----------------|----------|----------|
| Scenario 1 | Info on plate | Full Label @PL | MEPS@ FL | |
| Scenario 2 | Info on plate | Full Label @PL | MEPS@ FL | MEPS @PL |

Figure 8-2: History of measures leading to the transformation of the market in the direction of the LLCC, applied to the average size product, for easiness of understanding

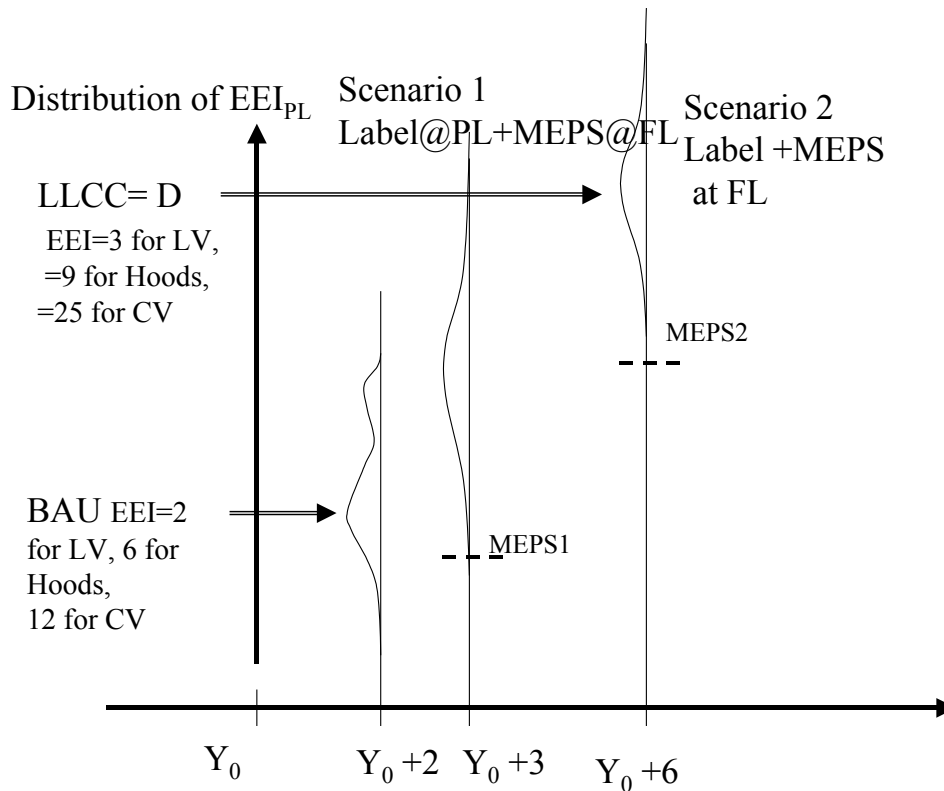

8.3 Other environmental requirements and their treatment

Noise and air quality. Among the issues treated in Annex I of the directive, noise is certainly important. Electromagnetic problems were not found. About air quality, care must be taken with hoods connections on the aeraulic circuit, so that polluted air cannot come back into the space. Noise limitation indoors is a specific constraint to be taken into account for the product design. In noisy areas the transmission of noise from outdoors can also be a constraint for the product design. The less noisy product will be identified by providing information to the purchaser of the product but most of the relevant work is done by the fitter who should use the proper passive noise filters as specified in MS building codes, or in the future, by active noise dampers.

Manufacturing requirements. Easy disassembly of the product should be encouraged which the WEEE directive will also promote.

Recommendations for installation, maintenance use and end of life. Many things depend on the installer, in terms of training and environmental consciousness. The fitter will influence:

- the choice of the product;
- the installation of switches or speed selectors for the user ;
- the choice and installation of products at several speeds, the flows being chosen by the installer;
- the choice of a product taking account of possible air quality requirements (typically moisture)
- the recycling of the product at its end of life and the proper treatment.

Filter maintenance is an important issue, highly cost effective to maintain real life performances of ventilation products.

Accompanying measures

There is a need for a proper timing because manufacturers and MS are not used to having a common EU energy efficiency definition for these products (to complement, rather than substitute, their more functional and/or building code information). There is a need for a form of accompanying measure or EIE study to help the manufacturers and laboratories to solve the many practical details in that time period. A budget of 500 000 Euros allocated to this work through technical centers would allow the testing of hundreds of pieces of equipment and the training of tens of technicians in the new methods. If the decision to use a part load label and MEPS@FL is made in 2008, all manufacturers can have the information ready within two years for all models, if the accompanying measure is launched at the same time. Only the two first MEPS seem to be acceptable on the basis of the EuP directive alone, since MS have conflicting regulation.

Note also that a new lot study about residential ventilation could be created to cover collective ventilation products (typically over 125 W). These are treated already in lot 11 but not specifically as residential products (but for tertiary or industrial applications). This would help to develop their specific control options to save energy while keeping an internal environmental quality in residential applications.

Support measures for companies are important because they are all SMEs : technical centers should be supported in the field of ventilation, market control should be really established by ordering a number of tests of products and by supporting certification systems that lower the risk of erroneous declaration for a small company at a reasonable cost of testing.

Benchmarks for best products for support at MS level

The efficiency levels for best products that could be used e.g. for the purposes of public procurement or fiscal incentives by Member States should be expressed in terms of EEI@PL, assuming the MS has no national regulation objecting to the reduction of flow in dwellings. In that case (no national regulation against part load) the study concludes that a present benchmark in line with category D corresponds to the LLCC : for “Local ventilation”: EEI@PL>2, for « Hoods » : EEI@PL>6, for “Central ventilation”=ICV : EEI @ PL>12.

Continuity with other legislation

The first and most important aspect is that a solution has been found that avoids any double action or conflict with national EPBD legislation. By concentrating on the product itself and on its best operational point, without any consideration of the pressure and flow where this occurs, the proposed measures work in the same direction as the EPBD (efficiency), but in a parallel manner. EPBD national legislation regulates building construction and renovation and may indicate desired pressure levels and flows or derived quantities like SFP. Taking this for granted the measures will improve the efficiency of the fan at that operating point.

Considering now continuity with the Working Document of the Commission “Working document on possible ecodesign requirements for ventilation fans.”, version dated May 2008, it is our understanding that it uses the same concept as the present study, the efficiency at the Best Efficiency Point. In that sense continuity is ensured.

Also there is consistency of testing standards. All test methods comply with ISO 5801 : “test method for fans”. European standards below refer to this only ISO test standard but build different testing conditions due to the difference between residential, industrial and tertiary use: EN 13141, Ventilation for buildings - Performance testing of components/products for residential ventilation, that we have used and EN13779 : non residential performance of ventilation systems (inc : SFP, filters...) that is in the domain of non residential use. So the continuity is ensured in that way also.

However the fans considered in the existing WD of “ventilation fans” are for heavy duty air handling in tertiary buildings not for residential ventilation, and there is clearly a discontinuity between the

extrapolation of WD limits down to 125W and the values found in the present study. To avoid applying the WD to some residential fans that could fall in the range (for instance in collective ventilation) but to which WD application is not technically feasible, various solutions have been investigated. The usage purpose by itself (residential versus tertiary or industrial) seems difficult to check because it only appears at the time of installation. Efficiency improvement possibilities and requirements on residential fans are lower than for other fans because of size effects, although residential fans can often benefit from more sophisticated control options that are also applicable up to 500W. Finally two solutions can be combined : limiting the WD to higher pressure products (over 200Pa for instance), and/or limiting the WD to higher power levels, with a further study to cover the domain and realise continuity at a power level higher than 125W (500W for instance).

8.4 Impact analysis

Impact on products

The statistics of products affected in the data basis is given by figure 8-4

Figure 8-3: Share of market (according to estimates limited to products on the scope only (excluding collective ventilation) affected by MEPS proposed

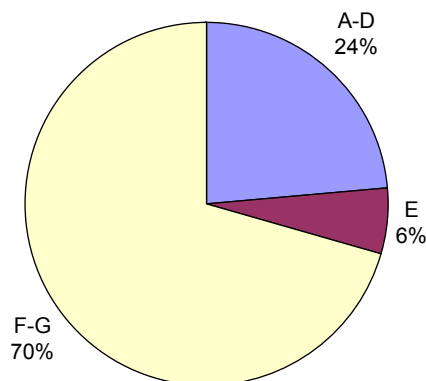

In the event that the proposed measures up to the BAT take effect at the indicative dates given, 24 % of the market models remains unaffected until around 2015 and have to be modified at that date. If the seven suggested requirements are implemented there is no conflict with MS regulations. The products reaching or exceeding the LLCC fall into class D class and above

Impact on industry and consumers

Impact on industry and the consumers has been approached by assuming a full transfer of overcosts from manufacturers to consumers and by basing measures on an affordable consumer life cycle cost. For instance the labeling could bring back the distribution of EEI@PL to a Gaussian distribution around the average, and for the MEPS the study assumed truncation of the Gaussian tail. On the short term the products are from EU and the additional demand will be directed to EU industry. Industry employment and competitiveness can increase in that sector if the EU products are labeled and have a minimum performance, because low impact mechanical ventilation can substitute poor existing mechanical or natural ventilation. The additional income of manufacturers could be put in line with 7000 jobs in 2025 if one accepts the common ratio of 100,000 Euros per job. Such an environmental

policy would also generate an EU quality mark followed by more EU competitiveness in foreign markets. The impact on manufacturers is positive but they have to move quickly and make use of R&D to lower the costs of improvements. For the time being the study assumes that the consumers would pay completely for the improvements at the present cost.

Can one accept the assumption of full transfer of overcosts (no loss for manufacturers), in the observed market structure? That is, are we close enough to the conditions of a market dominated by marginal costs, that will transmit any overcost into the prices without amplification or reduction? The structure is made of a web of SMEs, often very national (due to specific building codes and habits). For instance there are 6 manufacturing countries at least (underestimated due to the mentioned uncertainties in PRODCOM reporting), and 80% of products on the market of Scandinavia are Scandinavian, as well as 80% of market of the UK being from UK, and the like for France, Germany, etc. In each of the mentioned zones there is a minimum of 5 independent brands, usually more than 10. Typical sales are in the order of a few hundred thousand pieces. There is no proprietary technology in the seven requirements proposed.

One may consider that a quick movement by the EU ventilation industry in the adoption of the new energy efficiency standards is the best protection on the segment of “local ventilation” where products are easy to copy abroad, as occurred previously with comfort fans. Also if there is a movement of sales from this segment to the segment of central ventilation (already started due to MS building codes), it will be a move from a product that can be industrialized abroad by copying models to a sector where the EU industry is a creative leader.

In the segment of “central ventilation” the efficiency standard will contribute on the long term (2015?) to EU market unification but will not impair the short and medium term market position of EU manufacturers. The introduction of energy information will not impact on the situation of any “central ventilation” company (since they all use the same technique and have the same options in their laboratories) nor it will favour imports since the EU seems to be the clear world wide leader. It will have little impact on OEM because the manufacturers have usually the technology in house. The introduction of the proposed measures will benefit to consumers without deteriorating manufacturers margins.

The situation for “hoods” is different because there is a unified EU market driven mostly by design, rather than the low cost of the fan itself. There are two manufacturing countries and 7 significant companies, five of them around 1.5 M pieces a year, one at 3 M pieces, and one at 5 M pieces, on a total of 15.5 Mpcs produced. The EU seems to be the clear world wide leader for hoods, so there is no risk of parasitic imports for the time being. In fact the the opposite effect seems possible - a reinforcement of the image of EU products that are both more fashionable and also the most environmentally friendly. Without the proposed requirements the risk is higher that industry in the some fast evolving developing countries invade the EU markets with copies based on cheap labour cost, as has happened in other product areas.

As a conclusion of the analysis of the three markets, we examine the feasibility of a Voluntary Agreement to reach the same or more demanding MEPS than the proposed requirements . The local and central ventilation manufacturers are usually bound into a national framework with weak (relatively to other sectors) national manufacturers associations and a certain level of liaison through standardization committees and Eurovent. The hoods sector has a strong structure within Ceced and is capable of proposing a Voluntary Agreement leading to more savings than policy actions and more quickly.

Indeed there is no real legislation on the consumption by residential ventilation at EU level or abroad. The creation of the EU legislation would induce similar legislations in third countries after a delay. There is a US label (Energy Star) specific for some ventilation equipment posted on a voluntary basis, and for range hoods. There is no direct way of comparing the threshold of this US labeling scheme with the values proposed for EU labeling since the US standard has no relationship with international

standards, to the best present knowledge, as opposed to the EN standard the study is using. The only method would be to test a number of pieces of equipment under both standards and compare.

MS have presently in the EU a lot of national conflicting legislation about the ventilation requirement and internal air quality (see chapter 1), and some MS start to set bases for an electricity demand limitation, that will limit products mobility²⁵. The introduction of a common EU basis on residential ventilation products is urgent in order to ensure proper functioning of the internal market. The first steps of progress, namely moving from today averages to Lowest Life Cycle Cost solutions does not interfere with national legislation because it does not require the part load MEPS.

Impact on consumers : reaching the LLCC target

The data base of the present study was used to simulate the effects of the policy on the distribution of equipment put on the market sorted by grading categories introduced previously and the results are shown on table 8-4 and 5. The starting point (column “BAU”) shows a sharing of products between one quarter of the market which has already very high performance and the rest which has a quite low grading. The average EEI@PL are computed for each of the three categories of products.

As a result of scenario 1, the model transforms the frequency distribution, first in the direction of moving models under average to the average (column “labeling & MEPS@FL”) and recalculates the averages.

Then the same for MEPS@PL, which as opposed to MEPS@FL, has a significant impact because it is based on part load performance.

Finally the reader can compare the simulation of measures with the LLCC and of the BAT, which proves that the proposed measures are consistent with the objective of the Directive.

Table 8-4: Assumptions made to compute the effects of measures taken on products on the scope only (not CCV)

| Effects of a certain scenario on frequency of classes and average EEI | BAU | Scenario 1 : Label@PL + MEPS@FL | Scenario 2 : Label@PL + MEPS@PL |
|--|------------|--|--|
| Frequency of A-D | 24% | 24% | 100% over E |
| Frequency of E | 6% | 26% | - |
| Frequency of F-G | 71% | 50% | - |

²⁵ UK and French building codes, for example, have not been designed to protect national markets but request such an adaptation of the product to some specific features or values that they generate a kind of barrier for products from other countries (see chapter 1)

Table 8-5: Results obtained the effects of measures taken on products on the scope only (not CCV)

| Effects of a certain scenario on frequency of classes and average EEI | BAU | Scenario 1 : Label@PL + MEPS@FL | Scenario 2 : Label @PL+ MEPS@PL | LLCC | BAT |
|---|-----|---------------------------------|---------------------------------|-----------------------|-----|
| Average EEI PL “local ventilation” | 2 | 2,2 | 3,5 | EEI between 3 and 4 | 4 |
| Average EEI PL “hoods” | 6 | 9 | 10,6 | EEI between 9 and 15 | 18 |
| Average EEI PL “central ventilation” | 12 | 20 | 27,8 | EEI between 24 and 30 | 38 |

As far as one can predict market evolutions, the simulation of the package of requirements seems in agreement with the LLCC target, which is defined as a range resulting from the technical studies. As the reader remembers, obtaining the BAT requires further iterations with MS and R&D on manufacturers side. The benefits on the unitary consumption and LCC of products are already significant (tables 8-6 and 7).

Table 8-6: Benefits for the individual consumer of the measures in terms of unitary electricity consumption -products in the scope only (not collective ventilation of residential buildings)

| Yearly Energy Consumption of one single product | BAU (kWh/unit/a) | Scenario 1: Label@ PL +MEPS@FL (kWh/unit/a) | Scenario 2: Label +MEPS@ PL (kWh/unit/a) | BAT (kWh/unit/a) |
|---|------------------|---|--|------------------|
| “local ventilation” continuous (kWh/unit/a) | 148,92 | 135,4 | 85,1 | 74,5 |
| “local ventilation” intermittent (kWh/unit/a) | 12,41 | 11,3 | 7,1 | 6,2 |
| “local ventilation” weighted average (kWh/unit/a) | 26.0 | 23,6 | 14,9 | 13,0 |
| “Hood” intermittent (kWh/unit/a) | 65,7 | 43,8 | 37,2 | 26,3 |
| “central ventiation” continuous (kWh/unit/a) | 262,8 | 223,4 | 160,7 | 148,9 |

Table 8-7: Benefits for the individual consumer of the measures in terms of LCC -products in the scope only (not collective ventilation of residential buildings)

| LCC (Euros) of one single product | Purchase+ installation price of BAU (Euros) | LCC of BAU (Euros) | Scenario 1: Label @PL+MEPS @FL (Euros) | Scenario 2 : Label+ MEPS@ PL (Euros) | BAT (Euros) |
|--|---|--------------------|--|--------------------------------------|-------------|
| “local ventilation” continuous (Euros) | 30 | 241 | 221 | =221 | >221 |
| “local ventilation” intermittent (Euros) | 30 | 48 | 47 | =47 | >47 |
| “local ventilation” weighted average (Euros) | 30 | 64 | 63 | =63 | >63 |
| “Hood” intermittent (Euros) | 650 | 744 | =744 | =744 | 847 |

| | | | | | |
|--|-----|------|------|------|-------|
| “central ventilation” continuous (Euros) | 500 | 1177 | 1100 | 1030 | >1030 |
|--|-----|------|------|------|-------|

Some values (displayed with a = or a >) are shown equal to (or higher than) their neighbour in the table 8.7 when the differences are of the order of magnitude as the uncertainty and so cannot be certain. We have to analyse two situations of collateral impacts. On one hand for hoods all the calculations made for hoods used in ventilation (impact computed here) are applicable in recirculation mode and the end user will have about the same cost and benefit; the collateral aspect is positive. For local ventilation, if there were no permanent use, the benefit would not pay for the costs. With the very small percentage of permanent use fans assumed in the study, the total effect of the policy is already a significant gain, but concentrated on end users having a permanent use.

Benefits to the environment

The benefits in monetary and environmental terms are given hereunder for the full set of requirements, without harmonization of ventilation issues among MS. First, yearly consumption of one product used in one dwelling is computed as average power demand (including the effect of existence of multi speeds and other controls when relevant)* 8760 hours (or less if ON/OFF). Typically hoods and intermittent local ventilation fans are used ON/OFF and operate two hours a day. Electricity average price is 0.158 euro / kWh and discount rate equals 2 % in the economic calculation of benefits . The numbers of individual residences and apartments, as well as the ownership rates have been determined in the study and validated on existing field data. When and if the requirements are applied on the total stock of equipment in use, figure 8.4 gives the total gains of the proposed policy.

Figure 8-4: Impact of MEPS proposed applied to products on the scope only (excluding CCV)

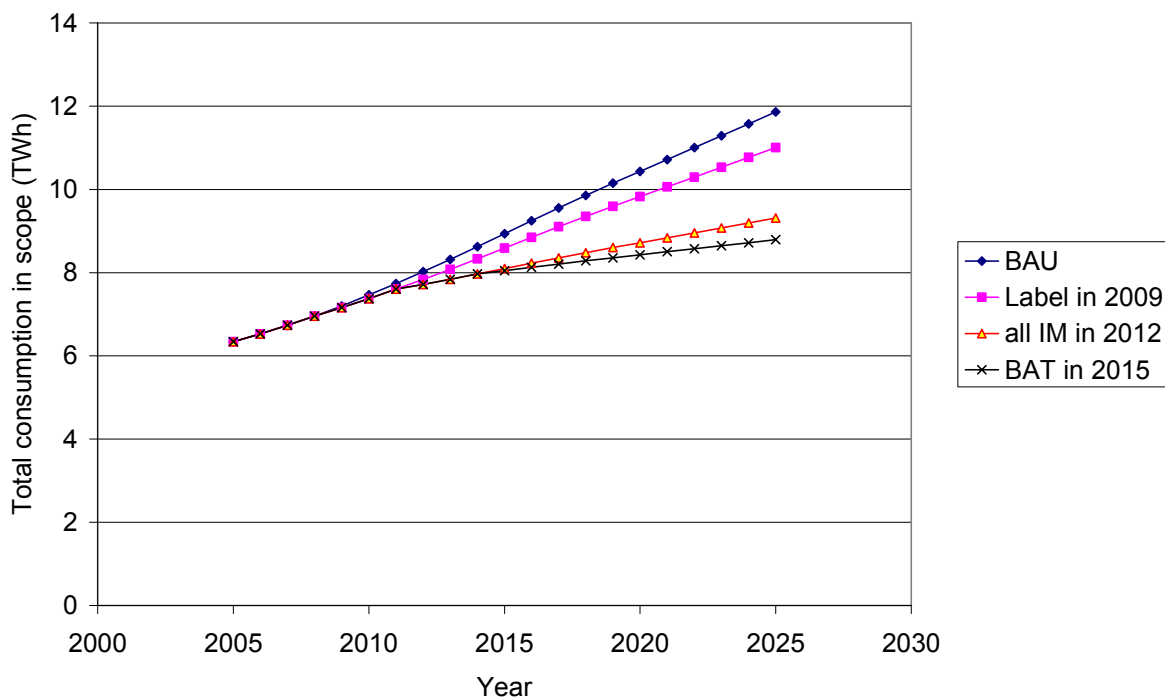

Tables 8-8 and 9 show the global benefits of the proposed scenarios up to year 2020, the year of present EU targets.

Table 8-8: Benefits on total electricity consumption of scenarios for products on the scope only (excluding CCV)

| | 2008 | 2009 | 2010 | 2011 | 2012 | 2013 | 2014 | 2015 | 2016 | 2017 | 2018 | 2019 | 2020 |
|--|------|------|------|------|------|------|------|------|------|------|------|-------|-------|
| Yearly Energy Consumption (TWh) | | | | | | | | | | | | | |
| BAU | 7,20 | 7,20 | 7,46 | 7,74 | 8,02 | 8,32 | 8,62 | 8,94 | 9,25 | 9,56 | 9,86 | 10,15 | 10,43 |
| Scenario 1 | 7,20 | 7,16 | 7,38 | 7,60 | 7,84 | 8,08 | 8,33 | 8,59 | 8,85 | 9,10 | 9,35 | 9,59 | 9,83 |
| Scenario 2 | 7,20 | 7,16 | 7,38 | 7,60 | 7,72 | 7,84 | 7,97 | 8,10 | 8,23 | 8,36 | 8,48 | 8,60 | 8,72 |

Table 8-9: Benefits on total electricity consumption of scenarios for products on the scope only (excluding CCV)

| | 2008 | 2009 | 2010 | 2011 | 2012 | 2013 | 2014 | 2015 | 2016 | 2017 | 2018 | 2019 | 2020 |
|---------------------------|------|------|------|------|------|------|------|------|------|------|------|------|------|
| CO2 emissions (Mt) | | | | | | | | | | | | | |
| BAU | 3,10 | 3,10 | 3,21 | 3,33 | 3,45 | 3,58 | 3,71 | 3,84 | 3,98 | 4,11 | 4,24 | 4,36 | 4,49 |
| Scenario 1 | 3,10 | 3,08 | 3,17 | 3,27 | 3,37 | 3,47 | 3,58 | 3,69 | 3,80 | 3,91 | 4,02 | 4,12 | 4,23 |
| Scenario 2 | 3,10 | 3,08 | 3,17 | 3,27 | 3,32 | 3,37 | 3,43 | 3,48 | 3,54 | 3,59 | 3,65 | 3,70 | 3,75 |

Table 8-10 shows the split of benefits of the proposed scenarios by year 2020, the year of present EU targets, among the categories.

Table 8-10: Benefits on total electricity consumption of products on the scope only (excluding CCV)

| Product type | Yearly Energy Consumption (GWh) BAU | Yearly Energy Consumption (GWh) Label+MEPS@FL | Yearly Energy Consumption (GWh) MEPS@PL | Yearly Energy Consumption (GWh) BAT | Energy Savings in GWh for Label+MEPS@FL | Energy Savings in GWh for MEPS@PL | Energy Savings in GWh for BAT | Savings in MtCO2 for Label+MEPS@FL | Savings in MtCO2 for MEPS@PL | Savings in MtCO2 for BAT |
|--------------------------------------|--|--|--|--|--|--|--------------------------------------|---|-------------------------------------|---------------------------------|
| “local ventilation” in 2020 | 1030 | 980 | 890 | 860 | 50 | 140 | 170 | 0,02 | 0,06 | 0,07 |
| “hoods” in 2020 | 2980 | 2880 | 2720 | 2680 | 100 | 260 | 300 | 0,04 | 0,11 | 0,13 |
| “central ventilation” in 2020 | 6430 | 5960 | 5120 | 4880 | 470 | 1310 | 1550 | 0,20 | 0,56 | 0,67 |
| Total of all categories | 10440 | 9820 | 8730 | 8420 | 620 | 1710 | 2020 | 0,27 | 0,74 | 0,87 |

The saving associated with the package of requirements (MEPS@ PL+ label) is around 1.7 TWh by year 2020 in the scope (about 0.7 MtCO₂). Since the same improvement will be brought by the manufacturers to the hoods that are not in the scope (recirculating hoods, the same product at the time of selling, see chapter 1), the gain on that segment will be doubled and bring an additional 0.26 TWh and 0.11 MtCO₂ saving. On total the scenario is around 2 TWh and 0.8 MtCO₂ saving.

If the requirements includes the lighting labeling (in lux/watt) there will be additional benefits that the lighting lot may have already estimated partly : on top of improvements in sources, we have here improvements on luminaries. A specific MEPS on hoods lighting in the frame of measures related with lighting is also possible due to the quality of information available and to the magnitude of improvements already put in place by some manufacturers on some kitchen hoods (from 40W for incandescent bulbs down to 20W for halogens , to 7W for some fluorescent lights and 3W for LEDs).

Specific factors of quality (Internal Air Quality) have been left unchanged. Member States regulation have been considered as unchangeable in the study. If harmonization takes place in the domain of ventilation, the proposed steps 2 and 3 of MEPS, based on part load, can then introduce a lot more positive impacts.

8.5 Sensitivity Analysis

Many factors can influence the results. One can consider varying raw materials and electricity prices and other relevant macro economic variables together consistently with the trends observed up to year 2007. However the LLCC found are robust to these variables.

An increase by 50% of both the electricity and materials price then a decrease by 33% were simulated and compared with the reference used in all EuP studies. It resulted in LCC curves of figure 8.6, showing how robust the minimum is. The study assumes that the consumers would pay completely the improvements at the present cost, and one can expect that the over cost will decrease and the improvements become more profitable when industrial R&D focuses on the problem

Figure 8-5: Comparison of the average EEI PL values and energy consumption of products showing some consistency and leaving room for two classes of grading under average

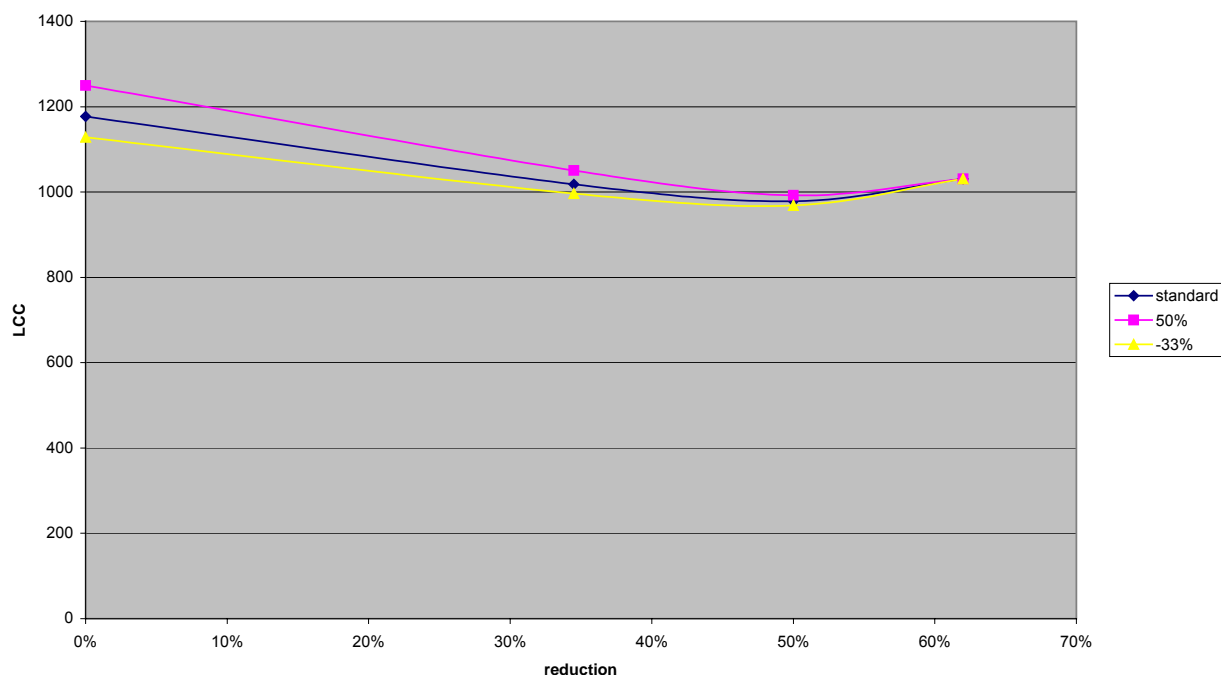

The basic data on the market are uncertain since no market study was pre existing to the present study. The best data from the manufacturers associations of some MS have still a margin of uncertainty of 20% but it is the best available data approved by the study team and by all stakeholders. The study mentioned strong uncertainties in PRODCOM reporting. If we use the estimate we mentioned at that time of +/- 20%, electrical consumption in 2020 in the scope is between 8.3 and 12.5 TWh and the savings possible with the policy between 1.6 and 2.4 TWh.

The projections made are conservative and subject to uncertainty. The central question is: to what extent are building regulations (e.g. developed under the Performance of Buildings Directive) leading to forced ventilation as a practical obligation in residences? This information will decide on the future market trends: either a stable evolution of the existing market or a rapid market change in the direction of centralised extraction. This uncertainty is not legal (since EPBD is enforced) but largely practical: thermal regulations for buildings generally open various ways of compliance; forced ventilation with a certain quality may be part of the less costly package of solutions to comply with the codes in one country and not in another country. Other uncertainties are related to the part of EPBD demanding energy efficiency improvements in case of building retrofit and the demand of the end user for more comfort in air quality. It is proposed that these uncertainties be addressed in the revision of the proposed requirements in five years from entry into force of these requirements.

For all intermittent local fans (either hoods or not) the duration of use is largely uncertain.

8.6 Summary of performance testing leading to EEI@PL and EEI @ FL (to become a technical annex of any requirement)

All the products in the scope should have their performance reported in a way allowing that shows the benefits of BAT. The procedure is based on test conditions in accordance EN 13141-4 test standard, except kitchen hoods for which CEI/IEC 61 591 : 2005 test standard is used. The hoods are identified as such by the manufacturer but for the other products the manufacturer or the laboratory has to determine if the product belongs to “Local ventilation” (when there is only one spigot for air suction) or “Central ventilation” (multiple spigots) before starting the test. The sections of EN 13141 concerning the two categories are very distinct and an exact reference to the test standard section in the product documentation avoids mixing products of the two categories. However, a manufacturer

can declare as “central ventilation fan” an equipment that has only one spigot but has been designed to serve various rooms by using other components to do so, and consequently the laboratory shall apply the respective procedure.

In most cases the product is an encased fan, but in some situations the manufacturer sells a package (or kit). The product is then everything that is sold jointly with the fan. It may contain sensors, simple extracts, extracts including some kind of sensor, etc. When there is a remote controller, the standby consumption associated should be measured separately as defined in lot 6. The laboratory determines whether there are different speeds and, if so, which is Full Load. The speeds we are referring to are not the settings that the manufacturer recommends to the installer to adjust on site, but those subject to the manual and automatic controls throughout the life of the product without further action by the installer. For the settings of the first type the default settings put in place by the manufacturer on the product will be kept. The highest possible speed available for the user with the factory settings is selected and the laboratory observes the behaviour of the control at this flow rate. If an automatic timer or sensor brings back the fan to a lower speed in less than two minutes, this reduced speed is used as the test condition and the other (higher) speed will be considered as a booster mode, not suitable for end user information.

The laboratory determines if there is in the package a sensor detecting indoor environmental needs such as humidity or carbon dioxide level and adjusting fan operation accordingly (by either mechanical sensor, analog or digital, or manual speed selection other than an on/off switch). In that case the operation and the standby consumption of control and sensors (except the remote controller) is included in the testing process, and there is no relevance in applying lot 6 procedures to that consumption. The control equipment is put into operation during the tests, with all factory settings unchanged. When the product includes a pressure sensor which is to be located at some undetermined place, it is placed the suction of the fan.

If requirements apply to products with balanced flow without heat recovery, the laboratory will consider only half of measured electrical input and only the exhaust flow rate. For hoods the grease filtering element can be left in place as it does not introduce a significant perturbation. This reflects the procedure in the present IEC standard. Hybrid ventilation fans (assistance fans) are to be treated as other fans.

Once the test speed has been determined and the controller put in operation, the characteristic line of the fan is measured at that speed. All information (for instance about noise) should be consistent, i.e. corresponding to the same situation, in this case the same speed.

When performing the test at full load, the laboratory determines the characteristic line over the full range of available flows, then determines the efficiency at each flow rate by computing Pelec, flow Q, total pressure difference ΔP^{26} , $Phydr = Q \times \Delta P$, $Efficiency = Phydr/Pelec$ (at the BEP) and identifies the operating point with the highest efficiency that can be reached on the full load curve without acting on the controller. The laboratory then keeps this point as BEP (Best Efficiency Point) at constant speed and the associated value of $Efficiency = Phydr/Pelec$ as $EEI @ FL$ (after multiplication by 100 and rounding, up or down). For this point that is called in the following (Q^* , ΔP^*) the laboratory reports Pelec, flow Q^* , total pressure difference ΔP^* , $Phydr = Q^* \times \Delta P^*$, $Efficiency = Phydr/Pelec$, $EEI @ FL$ (Full Load).

This test process is appropriate if the manufacturer is content not to include part load control gains. A default method to estimate $EEI @ PL$ is then to take 50 % of the $EEI @ FL$.

²⁶ The standard uses the total (dynamic) pressure, not the static one; we are doing the same.

If the manufacturers wants to measure EEI @ PL, this test is only one of the four tests needed: at 25 - 50 - 75 - 100 % of flow Q * The flow rates may be obtained by the normal operation of an automatic control which forms part of the product, or by manual selection by the laboratory of the lowest speed giving the appropriate flow. It is not to be obtained by adjusting control variables that are only accessible to the manufacturer or to the installer. All default settings not readily available to the end user are left as tuned in factory.

Each test requires measurement of ΔP_i , Q_i (flow), P_i (electric power demanded). ΔP_i cannot become too small, and should be higher than $\Delta P * x_i * x_i$ (square law of head losses), where x_i is the proportion of the nominal full flowrate (0.25 – 0.50 – 0.75 – 1.00).. The results are published so that they can be used for national weightings, and not only for the calculation of EEI @PL.

By using the frequencies of occurrence given in the following table, the following calculation leads to the determination of the EEI @PL.:

$$\sum F_i x_i Q^* \Delta P^*$$

$\sum F_i P_i$ determination where P_i are the electric power demands associated with the flows $x_i Q^*$

$$EEI (PL) = \frac{\sum F_i x_i Q^* \Delta P^*}{\sum F_i P_i}$$

rounded to the closest integer after multiplication by 100.

Practical EU values for x_i and F_i are given in the following table

| | | | | |
|--|--------|--------|--------|--------|
| Part load value in % of maximum flow x_i | 100% | 75% | 50% | 25% |
| Frequency of this situation F_i | 10,00% | 20,00% | 30,00% | 40,00% |

Appendix: Shape of ventilation fans

Table 66: Characteristics of fans used for ventilation in non residential buildings [AMCA, 1990]

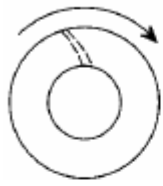
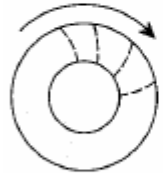
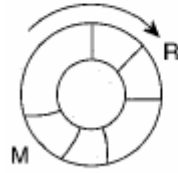
| Type | Impeller design | Performance characteristics | Applications |
|---|--|---|---|
| <p>Airfoil</p>  | <p>Highest efficiency of all centrifugal fan designs. 10 to 16 blades of airfoil contour curved away from the direction of rotation. Air leaves the impeller at a velocity less than its tip speed and relatively deep blades provide for efficient expansion within the blades passage. For given duty this will be the highest speed of the centrifugal-fan designs.</p> | <p>Highest efficiencies occur at 50 to 65 % of wide open volume. This is also the area of the good pressure characteristics. The horsepower curve reaches a maximum near the peak efficiency area and becomes lower towards free delivery. A self-limiting power characteristic as shows.</p> | <p>General heating, ventilation and air-conditioning systems. Usually applying only to large systems where the savings in power are significant. Can be used on low-, medium- and high-pressure systems. Used in large sizes for clean air industrial applications where power savings are significant.</p> |
| <p>Backward-inclined Backward-curved</p>  | <p>Efficiency is only slightly less than that of airfoil fans. Backward-inclined or backward-curved blades are single thickness. 10 to 16 blades curved or inclined away from the direction of rotation. Efficient for the same reasons given for the airfoil fan above.</p> | <p>Operating characteristics of this fan are similar to the airfoil fan mentioned above. Peak efficiency for this fan is slightly lower than the airfoil fan.</p> | <p>Same heating, ventilation and air-conditioning applications as the airfoil fan. Also used in some industrial applications where the airfoil blade is not acceptable because of corrosive and/or erosion environment.</p> |
| <p>Radial</p>  | <p>Simplest of all centrifugal fans and least efficient. Has high mechanical strength and the wheel is easily repaired. For a given point of rating this fan requires medium speed. This classification includes radial blades (R) and modified radial blades (M). Usually 6 to 10 in number.</p> | <p>Higher pressure characteristics than the above mentioned fans. Curve may have a break left of peak pressure but this usually is not sufficient to cause difficulty. Power rises continually to free delivery.</p> | <p>Used primarily for material-handling applications in industrial plants. Wheel can be rugged construction, and is simple to repair in the field. Wheel is sometimes coated with special material. This design also used for high-pressure industrial requirements. Not commonly found in HVAC applications.</p> |

Continuation ...

Table 66 (continuation)

| Type | Impeller design | Performance characteristics | Applications |
|---|--|--|--|
| <p>Forward-curved</p>  | <p>Efficiency is somewhat less than airfoil and backwards-curved bladed fans. Usually fabricated of lightweight and low cost construction. Has 24 to 64 shallow blades with both the heel and tip curved forward. Primary energy transferred to the air is by use of high velocity in the wheel for given duty. Wheel is smallest of all centrifugal types and operates at lowest speed. Primary energy transferred to the air is by use of high velocity in the wheel for given duty.</p> | <p>Pressure curve is less steep than that of backward-curved bladed fans. There is a dip in the pressure curve left of the peak pressure point and highest efficiency occurs to the right of peak pressure, 40 to 50 % of wide open volume. Fan should be rated to the right of peak pressure. Power curve rises continually toward free delivery and must be taken into account when motor is selected.</p> | <p>Used primarily in low-pressure heating, ventilation and air-conditioning applications such as domestic furnaces, central station units and packaged air-conditioning equipment from room air-conditioning units to roof top units.</p> |
| <p>Propeller</p>  | <p>Efficiency is low. Impellers are usually of inexpensive construction and limited to low-pressure applications. Impeller is of 2 or more blades, usually of single thickness attached to relatively small hub. Energy transfer is primarily in form of velocity pressure.</p> | <p>High flow rate but very low pressure capabilities and maximum efficiency is reached near free delivery. The discharge pattern of the air is circular in shape and the air stream swirls because of the action of the blades and the lack of straightening facilities.</p> | <p>For low-pressure and high-volume air moving applications such as circulation within a space or ventilation through a wall without attached ductwork. Used for makeup air applications.</p> |
| <p>Tube axial</p>  | <p>Somewhat more efficient than propeller fan design and is capable of developing a more useful static pressure. Number of blades usually from 4 to 8 and hub is usually less than 50 % of fan tip diameter. Blades can be of airfoil or single thickness cross section.</p> | <p>High flow rate characteristics with medium pressure capabilities. Performance curve includes a dip to the left of peak pressure which should be avoided. The discharge air pattern is circular and is rotating and whirling because of the propeller rotation and lack of guide vanes.</p> | <p>Low- and medium-pressure heating, ventilating and air-conditioning applications where air distribution on the downstream side is not critical. Also used in some industrial applications such as drying ovens, paint spray booths and fume exhaust systems.</p> |

Table 66 (continuation)



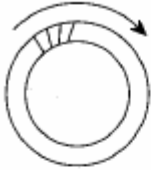
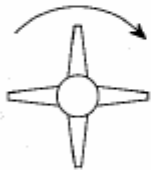
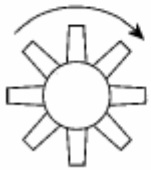

| Type | Impeller design | Performance characteristics | Applications |
|---|---|--|--|
| <p>Vane-axial</p>  | <p>Good design of blades permits medium- to high-pressure capability at good efficiency. The most efficient fans of this type have airfoil blades. Blades are fixed, adjustable or controllable pitch types and hub is usually greater than 50 % of fan tip diameter.</p> | <p>High-pressure characteristics with medium volume flow-rate capabilities. Performance curve includes a dip, caused by aerodynamic stall, to the left of peak pressure which should be avoided. Guide vanes correct the circular motions imparted to the air by the wheel and improve pressure characteristics and efficiency of the fan.</p> | <p>General heating, ventilating and air-conditioning systems in low-, medium- and high-pressure applications is of advantage where straight-through flow and compact installations are required. Air distribution on downstream side is good. Also used in industrial application similar to the tube-axial fan. Relatively more compact than comparable centrifugal-type fans for same.</p> |
| <p>Tubular</p>  | <p>This fan usually has a wheel similar to the airfoil backward-inclined or backward-curved blade as described above. (However, this fan wheel type is of lower efficiency when used in fan of this type). Mixed flow impellers are sometimes used</p> | <p>Performance is similar to backward-curve fan, except lower capacity and pressure because of the 90 degree change in direction of the air flow in the housing. The efficiency will be lower than the backward-curved fan. Some designs may have a dip in the curve similar to the axial-flow fan.</p> | <p>Used primarily for low-pressure return air systems in heating, ventilating, and air conditioning applications. Has straight-through flow configuration.</p> |
| <p>Power roof centrifugal ventilators</p>  | <p>Many models use airfoil or backward-inclined impeller designs. These have been modified from those mentioned above to produce a low-pressure-high-volume flow rate characteristic. In addition, many special centrifugal impeller designs are used, including mixed-flow design.</p> | <p>Usually intended to operate without attached ductwork and therefore to operate against very low-pressure head. It is usually intended to have a rather high volume-flow rate characteristic. Only static pressure and static efficiency are shown for this type of product.</p> | <p>For low pressure exhaust systems such as general factory, kitchen, warehouse, and commercial installations where the low pressure rise limitation can be tolerated. Unit has low initial cost and low operating cost and provides positive exhaust ventilation in the space which is a decided advantage over gravity type exhaust units. The centrifugal unit is somewhat quieter than the axial unit described below.</p> |

Table 66 (continuation)

| Type | Impeller design | Performance characteristics | Applications |
|---|---|--|---|
| <p>Power roof axial ventilators</p>  | <p>A great variety of propeller designs are employed with the objective of high-volume flow rates at low pressure.</p> | <p>Usually intended to operate without attached ductwork and therefore to operate against very low pressure head. It is usually intended to have a rather high volume-flow rate characteristic. Only static pressure and static efficiency are shown for this type of product.</p> | <p>For low pressure exhaust systems such as general factory, kitchen, warehouse, and commercial installations where the low pressure rise limitation can be tolerated. Unit is low in first cost and low in operating cost and provides positive exhaust ventilation in the space which is a decided advantage over gravity type exhaust units.</p> |
| <p>Tangential flow</p>  | <p>Impellers similar to those of multi-vane forward curved centrifugal fans are used. The action for this type of fan is radically different. A vortex is formed and maintained by the blade forces and has its axis parallel to the shaft and near to a point on the impeller circumference.</p> | <p>Efficiency is low but the fans are fairly quiet for their duty. To obtain a reasonable efficiency an adequate outlet diffuser is necessary since most of the pressure comes from the conversion of the high velocity pressure leaving the impeller.</p> | <p>Improvements in casing design have brought this type into prominence for use in certain small domestic appliances. They present long, narrow rectangular shape of inlets and outlets which opens up new possibilities for functional and appearance design for table fans and electric fan heaters.</p> |

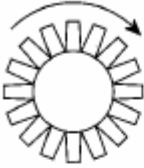
References

R1-Definition of product and standards

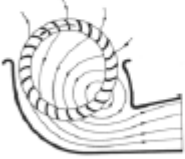
Radgen, 2007,

Promotelec, 2006,

Cory, W.T.W., 1992: Short History of Mechanical Fans and the Measurement of their Noise. CETIM Publication "FAN NOISE Bruit des Ventilateurs", International INCE Symposium, Senlis, France.

Ebmpapst, 2006, Ebmpapst communication, 29 Sept 2006.

Ecodesign Directive, 2005, European Parliament, Directive 2005/32/EC of the EP and of the Council of 6 July 2005 establishing a framework for the setting of Ecodesign requirements for energy-using products and amending council directive 92/42/EEC and directives 96/57/EC and 2000/55/EC of the European Parliament, Official Journal of the European Communities, L 1/65, Vol. 46, 4 January 2003

Uniclimate, 2006, "RT Batiments existants", private communication

FD CEN/TR 14788, Ventilation for buildings – Design and sizing of ventilation systems for single dwellings, Aug 2006.

EN ISO 13790, Thermal performance of buildings, Calculation of heating needs, Novembre 2004.

EN 832, Thermal performance of buildings, Calculation of heating needs for single dwellings, Aug 1999.

PrEN 15665, Ventilation in buildings - Determining performance criteria for design of residential ventilation systems

EN 13141, Ventilation for buildings - Performance testing of components/products for residential ventilation. Part 1 to 10.

EN 13142, Ventilation for buildings - Components/products for residential ventilation - Required and optional performance characteristics

PrEN 13779, Ventilation for non residential buildings – Performance requirements for ventilation and room conditioning systems

ISO 5801

SAP, 2005, - Appendix Q" was put in place in 2005, on behalf of the Energy Saving trust

Ventilation mécanique contrôlée - Bouches d'extraction autoréglables

NF, 2007, Certification Norme Française – NF 205 - Bouches d'extraction autoréglables, Groupe d'extraction, simple flux, autoréglables

CSTBat document "Testing code ESSAIS-HYG", dated July 2003, serving as a basis for CSTBat "certification"

NF-E-51-706

(LBL, 2005) Review of Literature Related to Residential Ventilation Requirements Jennifer McWilliams and Max Sherman June 2005

R2-Economic and market analysis

(TZWL) <http://www.tzwl.de>

Eurostat

(ATEE, 2006) White certificate form BR 114 on www.atee.fr

(ENPER 2006a) ENPER TEBUC EIE project, report B3

(ENPER 2006b) ENPER TEBUC EIE project, report B5

(Ledean, 2007) Survey of ventilation systems in Europe by Patrice Le Dean, Brice Febvre, Anne-Marie Bernard, Corresponding email: patrice.ledean@gazdefrance.com

(Radgen, 2002) Market study for improving energy efficiency of fans, Fraunhofer IRB Verlag, 2002

(Uniclimate, 2007) private communication

(VHK Lot1, 2006)

R3-Consumer behaviour and local infrastructure

CFP, 2006, « Les technologies performantes de ventilation », CFP Journal, 693, september 2006

Eurovent, 2004, Eurovent WG4B, paper by J Gustavsson in Eurovent review, dec 2004

Uniclimate brochure, Guide Climatization et santé.

AIVC 2005

(ADEME, 2007)

(SAP, 2006) two installation guides: Standard Assessment Procedure 2005 – Appendix Q MEV Installation Guide, “Installation Guide and Checklist Continuous Mechanical Extract Ventilation (Version – 20 July 2006)” and “Installation Guide and Checklist Mechanical Ventilation with Heat Recovery (Version – 20 July 2006)” The Electric Heating and Ventilation Association has developed this guidance and checklist document in partnership with the Residential Ventilation Association (a HEVAC association), BRE and EST.

R4-Technical Analysis Existing Products

(Vialle, 2006)

(Vialle, 2007) Pierre-Jean Vialle, Muriel Barbat, Bernard Collignan, CETIAT, COSTIC, CSTB, Development of an energy labelling for ventilation units, AIVC 2007

R5-Definition of Base-Case

R6-Technical Analysis BAT

AMCA, 1990: Fans and System. Air Movement and Control Association International,

Inc. (AMCA International): s. Publication 201-90.

Nipkow, Jürg, 2007: Enorme Effizienzpotentiale bei Kleinmotoren Motor Summit, Zürich, Schweiz

R7-Improvement Potential

R8-Scenario-, policy-, impact- and sensitivity analysis